

Spectrometer or FTIR Gas Flow Cell

The FCM flow cell is optimized for spectrometers and FTIRs and can also be used with tunable laser systems. It is compatible with fibers commonly used in the industry, accepting an SMA905 connectorized fiber with a core diameter of up to 1mm and a NA of 0.37. The cell uses large diameter CaF2 lenses for efficient coupling over an extreme wavelength range from 150 nm to 9 microns.

The cell is housed in a rugged vacuum tight enclosure made of 316 stainless steel. Pressure handling capabilities >400psi, inert wetted surfaces, >200°C operating temperature, and Swagelok fittings provide for versatile and durable applications.

The cell is designed as a single pass-through 10cm path. Please contact the factory if you desire other path lengths or specifications.

Specifications

Parameter

Wavelength Range	150nm to 9000nm
Fiber Interface	SMA905
Fiber Compatibility	To 1mm core and 0.37 NA
Path Length	10.0 cm
Operating Temperature	-40°C to +200°C
Fiber to Fiber Throughput ¹	>50%
Throughput Stability Over Temperature	< 10% change: 15°C - 40°C
Spectral ripple (P-P)	<0.01dB P-P in any 2nm span
Wetted surfaces	316 SS, viton gaskets, CaF2, 353ND Epoxy
Storage temperature	-40°C to +200°C
Swagelok® fitting style	1/4" or 1/8" tube, hose bib available
Leak rate	<10 ⁻⁵ cc-atm/sec
Cell Pressure	0 to 3 MPa (430psi)
Cell volume	11cc

Notes:

1. At 25°C and 650nm using 200 micron core 0.22 NA fiber.



Features

- **Wavelength operation from 150nm to 9 microns**
- **Designed for minimum optical interference artifacts**
- **Swagelok® fittings for easy integration**
- **Compatible with SMA905 connectors.**

Applications

- **Gas sensing systems from the deep UV to the Mid-IR**
- **Spectroscopic research**
- **Chemical detection systems**

Ordering Information

FCM - 10 - ¼

Swagelok® tube style:
1/4 - ¼" tube
1/8 - 1/8" tube
HB - hose bib

Package Drawing (dimensions in inches)

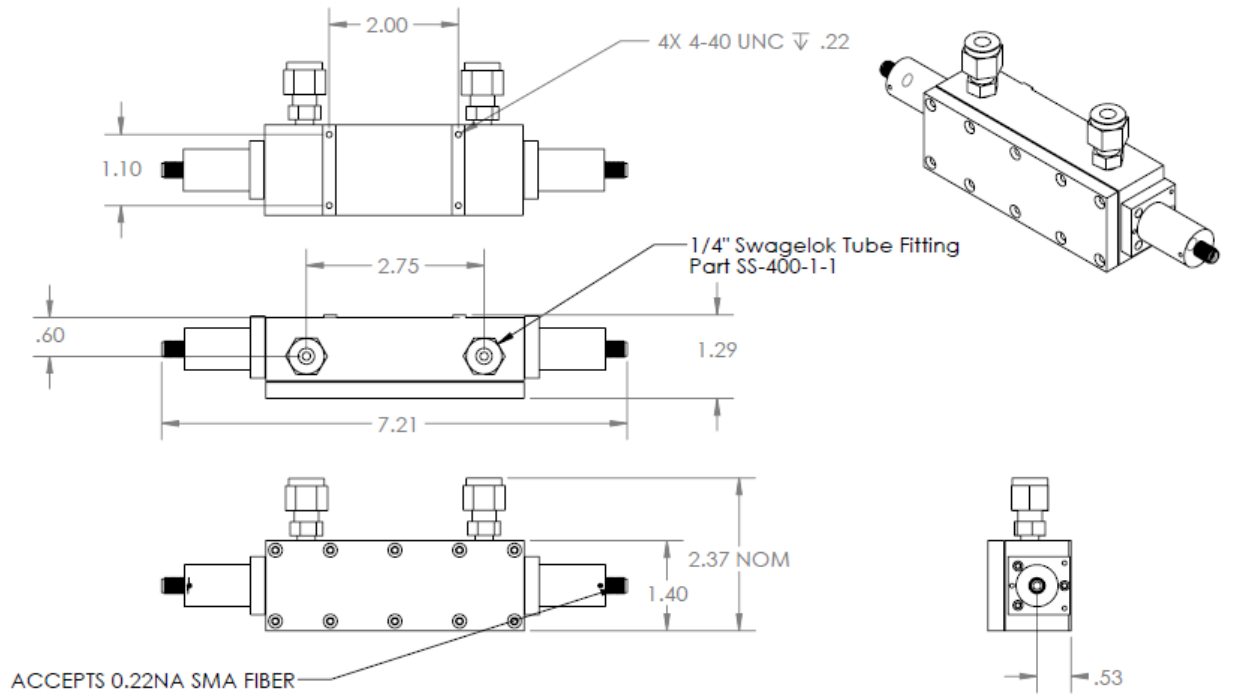

Flowcell operation:

Wavelength References Flowcells are very simple to use. For best results, however, note the following:

1. The cell is provided with four mounting holes tapped with 4-40 threads on the bottom.
2. Do not apply mechanical stress on the endcaps. These hold the CaF₂ collimating lenses.
3. If you require valves on the cell inquire as these can be provided, we can offer high quality needle or diaphragm valves.
4. Prevent dust and condensation from entering the cell. Uniform heating can reduce condensation and aids in moisture removal from the cell surfaces. Initial pump down with some heating is very beneficial for low background water vapor.
5. If the cell optics are damaged due to contamination we can rework the cell for lifetime cost savings. Please contact factory.