



FIBER LASERS

PowerLine F Series
for Marking and Micro Processing



POWERLINE F 20/30/50/100

Lasers for industrial material processing

PowerLine F series lasers are innovative fiber lasers with different power levels. All lasers in this model series deliver 1 mJ of pulse energy with high power output levels across a wide frequency range. The average power of our fiber lasers can be continuously adjusted.

The PowerLine F 50 and F 100 lasers can be operated with pulse frequencies of up to 200 kHz. These lasers are thus particularly suited to high-speed marking, scribing and edge isolation as well as structuring and cutting applications.

YOUR BENEFITS

- Low overall operating costs
- A range of power levels
- Dual-head configurations possible to increase the size of the marking area
- High flexibility thanks to different options (camera, positioning axes, etc.)



POWERLINE F 20 VARIA

Laser marking for particularly high demands

Thanks to variable pulse widths, the PowerLine F 20 Varia delivers outstanding results in highly demanding applications (e.g. corrosion-free marking). The excellent beam quality ensures the highest levels of precision and exceptional marking results on a consistent basis.

Not only can the PowerLine F 20 Varia deliver outstanding marking results at high speeds in applications where a lot of material (metal, for example) is removed; with its variable pulse widths, it can also handle delicate, high-precision work in high-speed applications.

PRODUCT FEATURES

- High repetition rates from a few kHz to MHz
- Extremely flexible as a result of variable pulse widths
- Short rise time
- Dual-head configuration possible

TECHNICAL DATA POWERLINE F 20, F 20 VARIA AND F 30

Laser and galvo PowerLine F 20

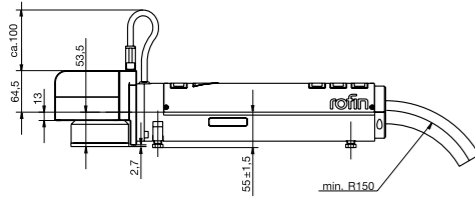

Side view

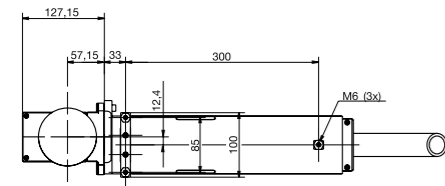

Bottom view

Laser and galvo PowerLine F 20 Varia

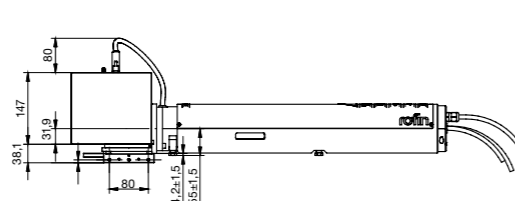

Side view

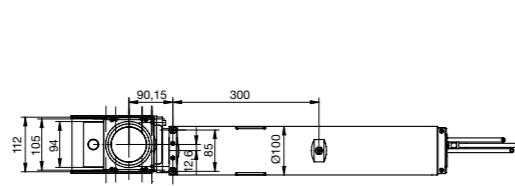

Bottom view

Laser and galvo PowerLine F 30

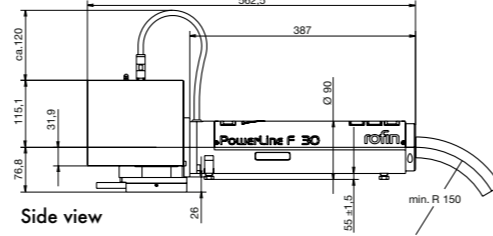

Side view

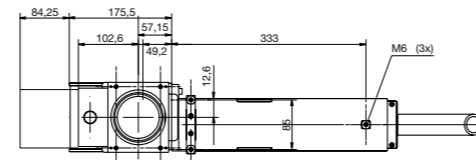

Bottom view

Supply unit incl. PC PowerLine F 20 Varia

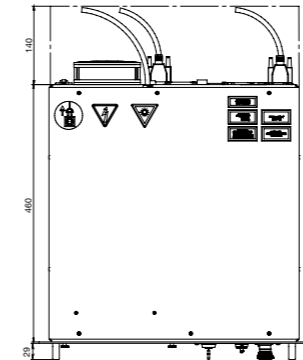

Top view

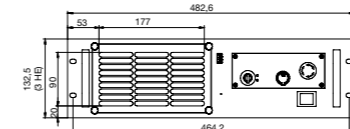

Front view

Supply unit PowerLine F 20 / F 30

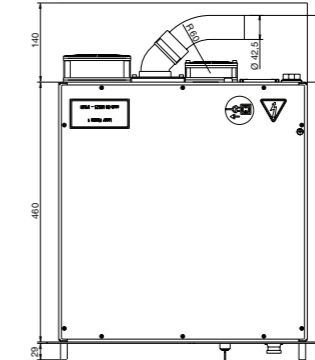

Top view

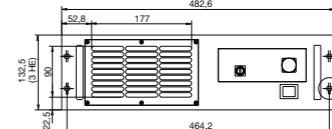

Front view

PC PowerLine F 20 / F 30

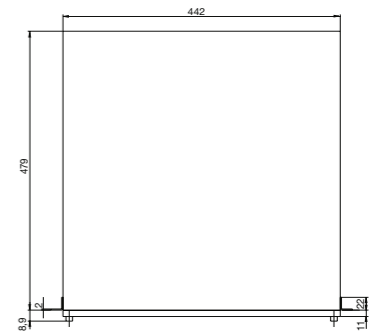

Top view

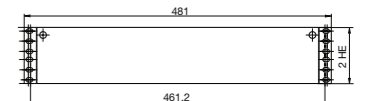

Front view

	PowerLine F 20	PowerLine F 20 Varia	PowerLine F 30
Laser head			
Wavelength (nm):	1064	1064	1064
Power class (W):	20	20	30
Pulse frequency (kHz):	20 - 100	2 - 1000	30 - 100
Pulse width (ns):	100 +/- (20 kHz)	4 - 200, adjustable	100 +/- 20 (30 kHz)
Dimensions (length, Ø, mm):	387, 90	594, 100	387, 90
Weight (kg):	approx. 5.5	approx. 7.5	approx. 5.7
Ingress protection:	IP 54	IP 54	IP 54
Marking unit			
Field size (mm):	120 x 120 (f=160 mm)*	120 x 120 (f=160 mm)*	120 x 120 (f=160 mm)*
Ingress protection:	IP 54	IP 54	IP 54
Weight (without objective) (kg):	approx. 3	approx. 3	approx. 3
Supply unit (19") and PC			
Supply unit dimensions (W x D x H, mm):	19" x 463 x 3 rack units	19" x 463 x 3 rack units	19" x 463 x 3 rack units
Supply unit weight (kg):	approx. 23.5	approx. 21	approx. 23.5
PC dimensions (W x D x H, mm):	19" x 479 x 2 rack units	PC integrated in supply unit	19" x 479 x 2 rack units
Software:	Windows Embedded 2009, Windows Embedded Standard 7	Windows Embedded 2009, Windows Embedded Standard 7	Windows Embedded 2009, Windows Embedded Standard 7
Power supply:	115 - 240 VAC, +/-10% VAC, 50/60 Hz	115 - 240 VAC, +/-10% VAC, 50/60 Hz	115 - 240 VAC, +/-10% VAC, 50/60 Hz
Power consumption supply unit incl. PC (W):	approx. 330	approx. 300	approx. 390
Ingress protection:	IP 20	IP 20	IP 20
Operating temperature (°C):	15 - 35	15 - 35	15 - 35
Air flow 19" supply unit (m³/h):	approx. 130	approx. 180	approx. 130
Length external cabling (m):	2.6	1.65	2.6

* Other on request

TECHNICAL DATA POWERLINE F 50 / F 100

Laser and galvo PowerLine F 50

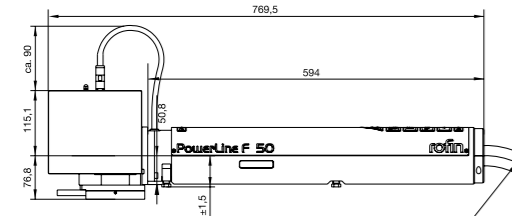

Side view

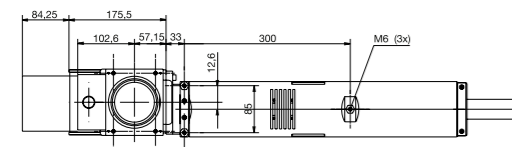

Bottom view

Laser and galvo PowerLine F 100

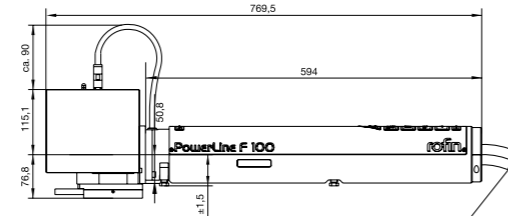

Side view

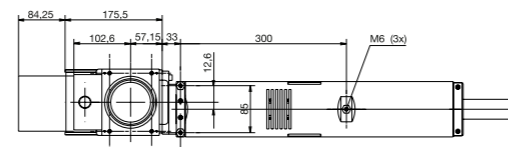

Bottom view

Supply unit PowerLine F 50 / F 100

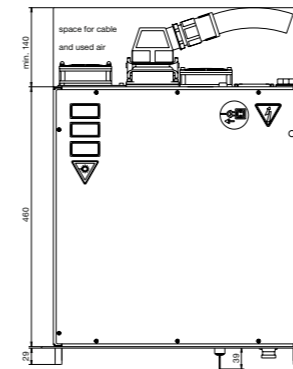

Top view

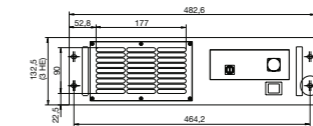

Front view PowerLine F 50

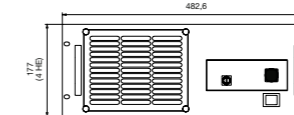

Front view PowerLine F 100

PC PowerLine F 50 / F 100

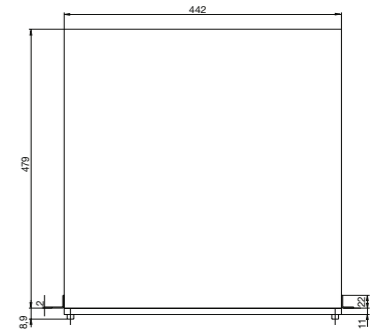

Top view

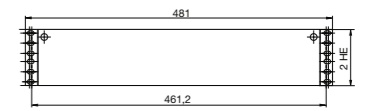

Front view

Laser head	PowerLine F 50
Wavelength (nm):	1064
Power class (W):	50
Pulse frequency (kHz):	50 - 200
Pulse width (ns):	120 +/- 20 (50 kHz)
Dimensions (length, Ø, mm)	594, 100
Weight (kg):	approx. 8.6
Ingress protection:	IP 54

Marking unit	PowerLine F 50
Field size (mm):	120 x 120 (f=160 mm)*
Ingress protection:	IP 54
Weight (without objective) (kg):	approx. 3

Supply unit (19") and PC	PowerLine F 50
Supply unit dimensions (W x D x H, mm):	19" x 463 x 3 rack units
Supply unit weight (kg):	approx. 28
PC dimensions (W x D x H, mm):	19" x 479 x 2 rack units
Software:	Windows Embedded 2009, Windows Embedded Standard 7
Power supply:	115 - 240 VAC, +/-10% VAC, 50/60Hz
Power consumption supply unit incl. PC (W):	approx. 470
Ingress protection:	IP 20
Operating temperature (°C):	15 - 35
Air flow 19" supply unit (m³/h):	approx. 130
Length external cabling (m):	2.6

* Other on request

Laser head	PowerLine F 100
Wavelength (nm):	1064
Power class (W):	100
Pulse frequency (kHz):	5.1 - 200
Pulse width (ns):	100 +/- 20 (100 kHz)
Dimensions (length, Ø, mm)	594, 100
Weight (kg):	approx. 8.6
Ingress protection:	IP 54

Marking unit	PowerLine F 100
Field size (mm):	120 x 120 (f=160 mm)*
Ingress protection:	IP 54
Weight (without objective) (kg):	approx. 3

Supply unit (19") and PC	PowerLine F 100
Supply unit dimensions (W x D x H, mm):	19" x 463 x 4 rack units
Supply unit weight (kg):	approx. 28
PC dimensions (W x D x H, mm):	19" x 479 x 2 rack units
Software:	Windows Embedded 2009, Windows Embedded Standard 7
Power supply:	115 - 240 VAC, +/-10% VAC, 50/60Hz
Power consumption supply unit incl. PC (W):	approx. 570
Ingress protection:	IP 20
Operating temperature (°C):	15 - 35
Air flow 19" supply unit (m³/h):	approx. 170
Length external cabling (m):	2.6

* Other on request

LASER MARKING

ROFIN-SINAR Laser GmbH
 Dieselstr. 15
 85232 Bergkirchen
 Germany
 Phone: +49(0)8131-704-0
 Fax: +49(0)8131-704-4100
 E-mail: info@rofin-muc.de

LASER MICRO

ROFIN-BAASEL Lasertech GmbH & Co. KG
 Petersbrunner Str. 1b
 82319 Starnberg
 Germany
 Phone: +49(0)8151-776-0
 Fax: +49(0)8151-776-4159
 E-mail: sales@baasel.de

LASER MACRO

ROFIN-SINAR Laser GmbH
 Berzeliusstraße 87
 22113 Hamburg
 Germany
 Phone: +49(0)40-733-63-0
 Fax: +49(0)40-733-63-4100
 E-mail: info@rofin-ham.de

WWW.ROFIN.COM

More brochures of ROFIN:



DE/AT: Phone +49-(0)831-704-0
 E-mail: info@rofin.de

Benelux: Phone +31-(0)78-69310-37
 E-mail: info@rofin-baasel.nl

CA: Phone +1-905-607-0400
 E-mail: info-canada@rofin-inc.com

CH: Phone +41-(0)32-3221010
 E-mail: info@rofin-baasel.ch

CN: Phone +86-21-6855-2216
 E-mail: info@rofin-baasel.com.cn

ES/PT: Phone +34-948-324-600
 E-mail: info@rofin-es.com

F: Phone +33-(0)1-6911-3636
 E-mail: info@rofin.fr

IN: Phone +91-(22)2761251/2/3/5
 E-mail: info@rofin.in

IT: Phone +39-039-2729-1
 E-mail: info@rofin.it

JP: Phone +81-(0)46-229-8655
 E-mail: info@rofin-baasel.co.jp

KR: Phone +82-(0)2-837-1750
 E-mail: info@rofin-baasel.co.kr

SG: Phone +65-6482-1091
 E-mail: reception@rofin-baasel.com.sg

TW: Phone +886-2-2790-1300
 E-mail: info@rofin-baasel.com.tw

UK: Phone +44-(0)1327-701-100
 E-mail: sales@rofin-baasel.co.uk

US: Phone: +01-734-455-5400
 E-mail: info@rofin-inc.com

Find additional service contacts on
www.rofin.com/worldwide