



Genesis CX SLM-Series

Single Frequency UV and Visible OEM and End-User OPS Laser Systems

Applications such as spectroscopy, interferometry, and holography require single-frequency lasers with narrow linewidths and long coherence lengths. The Genesis CX SLM-Series provides up to 100 mW of UV laser light or up to 4W of visible laser light from either a simple, CDRH-compliant turn-key system or an OEM system designed for easy mechanical integration into commercial instruments and production tools.

Based on Coherent's unique Optically Pumped Semiconductor Laser (OPSL) technology, the Genesis CX SLM-Series features single-frequency operation for the most demanding of applications. This, combined with stable beam parameters across output powers, a diffraction limited beam, lowest noise and high stability, provides unparalleled laser performance in a convenient package.

Genesis CX SLM-Series is the perfect match for customers in need of the highest performing CW laser technology for research and instrumentation in life science and biological applications.

FEATURES

- Single Longitudinal Mode
- Single Transverse Mode (TEM₀₀)
- OEM or end-user versions
- Air or water-cooled solutions
- Power Invariant beam quality

APPLICATIONS

- Spectroscopy
- Interferography
- Holography



SPECIFICATIONS ¹	Genesis CX 355 ²
Wavelength (nm)	355 ±2
FWHM Linewidth (MHz)	<5
Pulse Format	CW
Spectral Purity (%)	>99
Output Power (mW)	40, 60, 80, 100
Spatial Mode	TEM ₀₀
Beam Quality (M ²)	<1.2
Beam Circularity ³	1.0 ±0.1
Beam Waist Diameter (mm) (FW, 1/e ²)	
Horizontal	0.975 ±0.2
Vertical	0.915 ±0.2
Beam Divergence (mrad) (FW, 1/e ²)	<1.2
Beam Waist Location ⁴ (mm)	±325
Beam Pointing Stability ⁵ (μrad/°C)	<6
Horizontal Beam Position Tolerance (mm)	±<1.0
Vertical Beam Position Tolerance (mm)	±<1.0
Beam Pointing Tolerance (mrad)	<5
Polarization Ratio	Linear, >100:1
Polarization Direction	Vertical, ±5°
Noise (% rms) (10 Hz to 1 MHz)	<0.1
Power Stability ⁶ (%) (pk-pk)	±<1
Warm-up Time (minutes)	<10
CDRH Compliant	Yes
ELECTRICAL SPECIFICATIONS	
Operating Voltage (VAC)	100 to 240
Frequency (Hz)	50 to 60
Power Consumption (W)	500
ENVIRONMENTAL CONDITIONS	
Ambient Temperature (°C)	
Operating	10 to 40
Non-operating	-10 to 60
Relative Humidity ⁷ (%)	5 to 95
CE Marking	IEC 61010-1/EN 61010-1
Dimensions (L x W x H)	
Laser Head ⁸	281 x 156 x 85 mm (11.06 x 6.14 x 3.35 in.)
Cables (laser head to controller)	2m (6.5 ft.)

¹ Optical parameters measured at the output plane of the laser head. Unless noted all parameters valid for the lifetime of the unit.

² Available in OEM or end user versions.

³ Circularity defined as vertical diameter divided by horizontal diameter.

⁴ Negative value corresponds to a location inside head.

⁵ After warm-up over 2 hours.

⁶ Measured over 8 hours.

⁷ Non-condensing.

⁸ Back connector not included in laser head length dimension.

SPECIFICATIONS ¹	Genesis CX 460 ²	Genesis CX 480 ²	Genesis CX 488 ²
Wavelength (nm)	460 ±3	480 ±3	488 ±3
FWHM Linewidth (MHz)		<5	
Pulse Format		CW	
Spectral Purity (%)		>99	
Output Power (mW)	1000	2000	2000
Spatial Mode		TEM ₀₀	
Beam Quality (M ²)		<1.1	
Beam Circularity ³		1.0 ±0.1	
Beam Waist Diameter (mm) (FW, 1/e ²)	2.1 ±0.3	2.1 ±0.3	2.2 ±0.3
Beam Divergence (mrad) (FW, 1/e ²)		<0.5	
Beam Waist Location ⁴ (m)		±0.5	
Beam Pointing Stability ⁵ (μrad/°C)		<2	
Horizontal Beam Position Tolerance ⁶ (mm)		±<1.0	
Vertical Beam Position Tolerance ⁶ (mm)		±<1.0	
Beam Pointing Tolerance ⁶ (mrad)		<5	
Polarization Ratio		Linear, >100:1	
Polarization Direction		Horizontal, ±5°	
Noise (% rms) (10 Hz to 10 MHz)		<0.1	
Power Stability ⁷ (%) (pk-pk)		±<1	
Warm-up Time (minutes)		<10	
CDRH Compliant		Yes	
UTILITY REQUIREMENTS			
Operating Voltage (VAC)		100 to 240	
Frequency (Hz)		50 to 60	
Power Consumption (W)		500	
Cooling Requirements		Actively cooled heat sink required e.g. Genesis CX Air-Cooled Riser or Genesis CX Water-Cooled Riser	
ENVIRONMENTAL CONDITIONS			
Ambient Temperature (°C)			
Operating		10 to 40	
Non-operating		-10 to 60	
Relative Humidity ⁸ (%)		5 to 95	
CE Marking		IEC 61010-1/EN 61010-1	
Dimensions (L x W x H)			
Laser Head ⁹		281 x 156 x 85 mm (11.06 x 6.14 x 3.35 in.)	
Cables (laser head to controller)		2m (6.5 ft.)	

¹ Optical parameters measured at the output plane of the laser head. Unless noted all parameters valid for the lifetime of the unit.

² Available in OEM or end user versions.

³ Circularity defined as vertical diameter divided by horizontal diameter.

⁴ Negative value corresponds to a location inside head.

⁵ After 2-hour warm-up.

⁶ Measured at the output window.

⁷ Measured over 8 hrs.

⁸ Non-condensing.

⁹ Back connector not included in laser head length dimension.

SPECIFICATIONS ¹	Genesis CX 514 ²	Genesis CX 532 ²	Genesis CX 561	Genesis CX 577 ²	Genesis CX 590
Wavelength (nm)	514 ±3	532 ±3	561 ±3	577 ±3	590 ±3
FWHM Linewidth (MHz)	<5				
Pulse Format	CW				
Spectral Purity (%)	>99				
Output Power (mW)	2000, 4000	2000, 4000	2000	2000	1000
Spatial Mode	TEM ₀₀				
Beam Quality (M ²)	<1.1				
Beam Circularity ³	1.0 ±0.1				
Beam Waist Diameter (mm) (FW, 1/e ²)	2.2 ±0.3	2.3 ±0.3	2.3 ±0.3	2.3 ±0.3	2.4 ±0.3
Beam Divergence (mrad) (FW, 1/e ²)	<0.5				
Beam Waist Location ⁴ (m)	±0.5				
Beam Pointing Stability ⁵ (μrad/°C)	<2				
Horizontal Beam Position Tolerance ⁶ (mm)	±<1.0				
Vertical Beam Position Tolerance ⁶ (mm)	±<1.0				
Beam Pointing Tolerance ⁶ (mrad)	<5				
Polarization Ratio	Linear, >100:1				
Polarization Direction	Horizontal, ±5°				
Noise (% rms) (10 Hz to 10 MHz)	<0.1				
Power Stability ⁷ (%) (pk-pk)	±<1				
Warm-up Time (minutes)	<10				
CDRH Compliant	Yes				
ELECTRICAL SPECIFICATIONS					
Operating Voltage (VAC)	100 to 240				
Frequency (Hz)	50 to 60				
Power Consumption (W)	500				
ENVIRONMENTAL CONDITIONS					
Ambient Temperature (°C)					
Operating	10 to 40				
Non-operating	-10 to 60				
Relative Humidity ⁸ (%)	5 to 95				
CE Marking	IEC 61010-1/EN 61010-1				
Dimensions (L x W x H)					
Laser Head ⁹	281 x 156 x 85 mm (11.06 x 6.14 x 3.35 in.)				
Cables (laser head to controller)	2m (6.5 ft.)				

¹ Optical parameters measured at the output plane of the laser head. Unless noted all parameters valid for the lifetime of the unit.

² Available in OEM or end user versions.

³ Circularity defined as vertical diameter divided by horizontal diameter.

⁴ Negative value corresponds to a location inside head.

⁵ After 2-hour warm-up.

⁶ Measured at the output window.

⁷ Measured over 8 hrs.

⁸ Non-condensing.

⁹ Back connector not included in laser head length dimension.

MECHANICAL SPECIFICATIONS

**Genesis CX-Series
High Current OEM Power Supply**

Top View

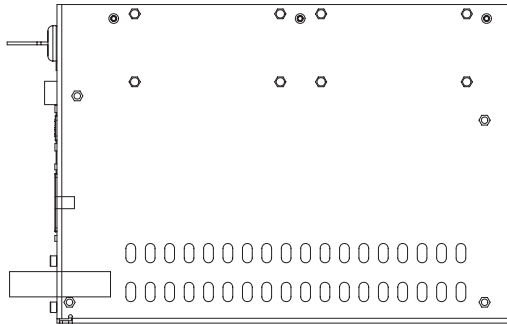

Side View

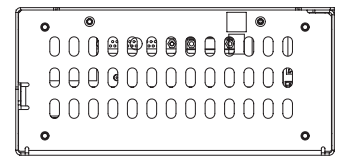
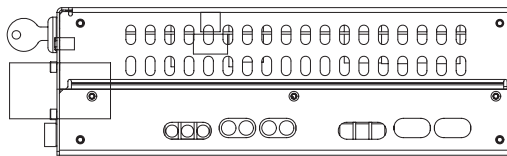

Rear View

Bottom View

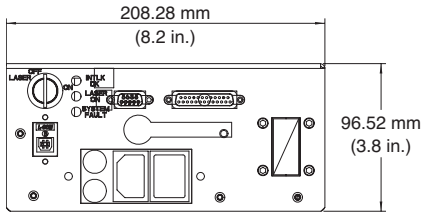
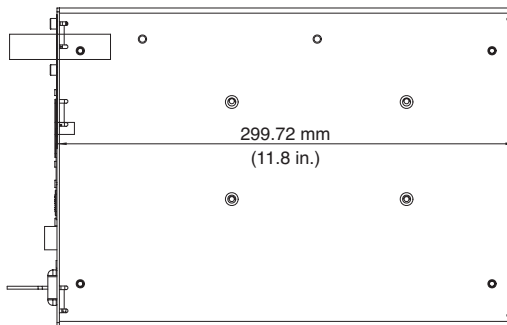

Front View

**Genesis CX-Series
Benchtop Power Supply**

Front View

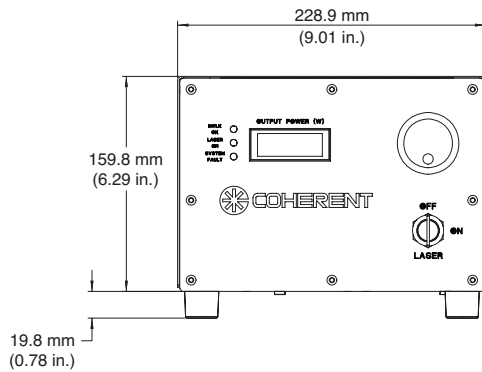

Side View

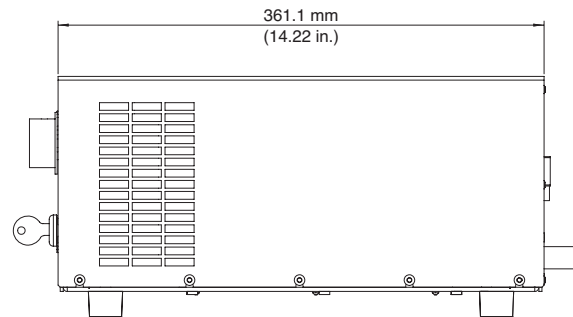

MECHANICAL SPECIFICATIONS

**Genesis CX SLM-Series
OEM and End User**

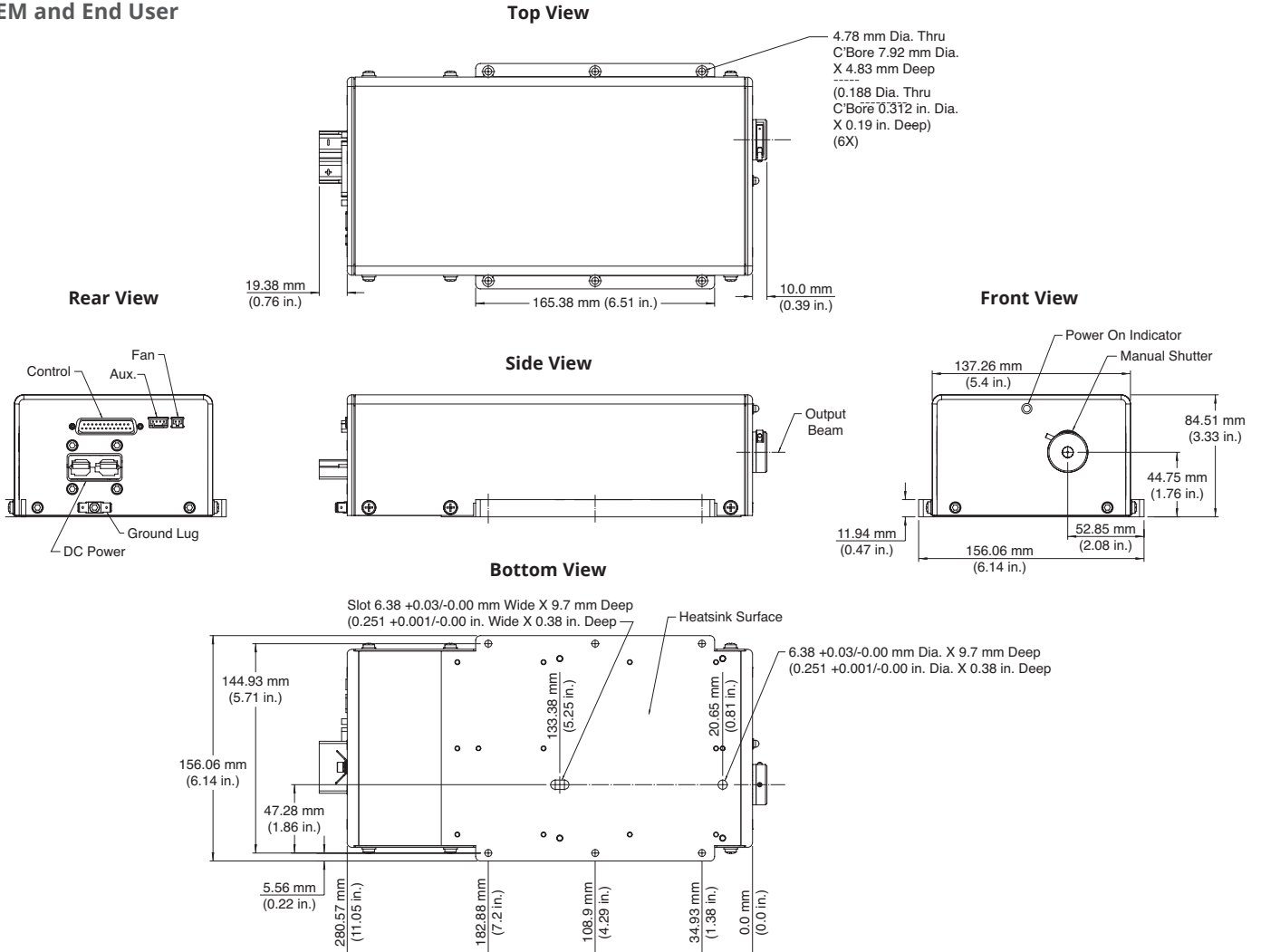

MECHANICAL SPECIFICATIONS

**Genesis CX SLM-Series
Air-Cooled Riser**

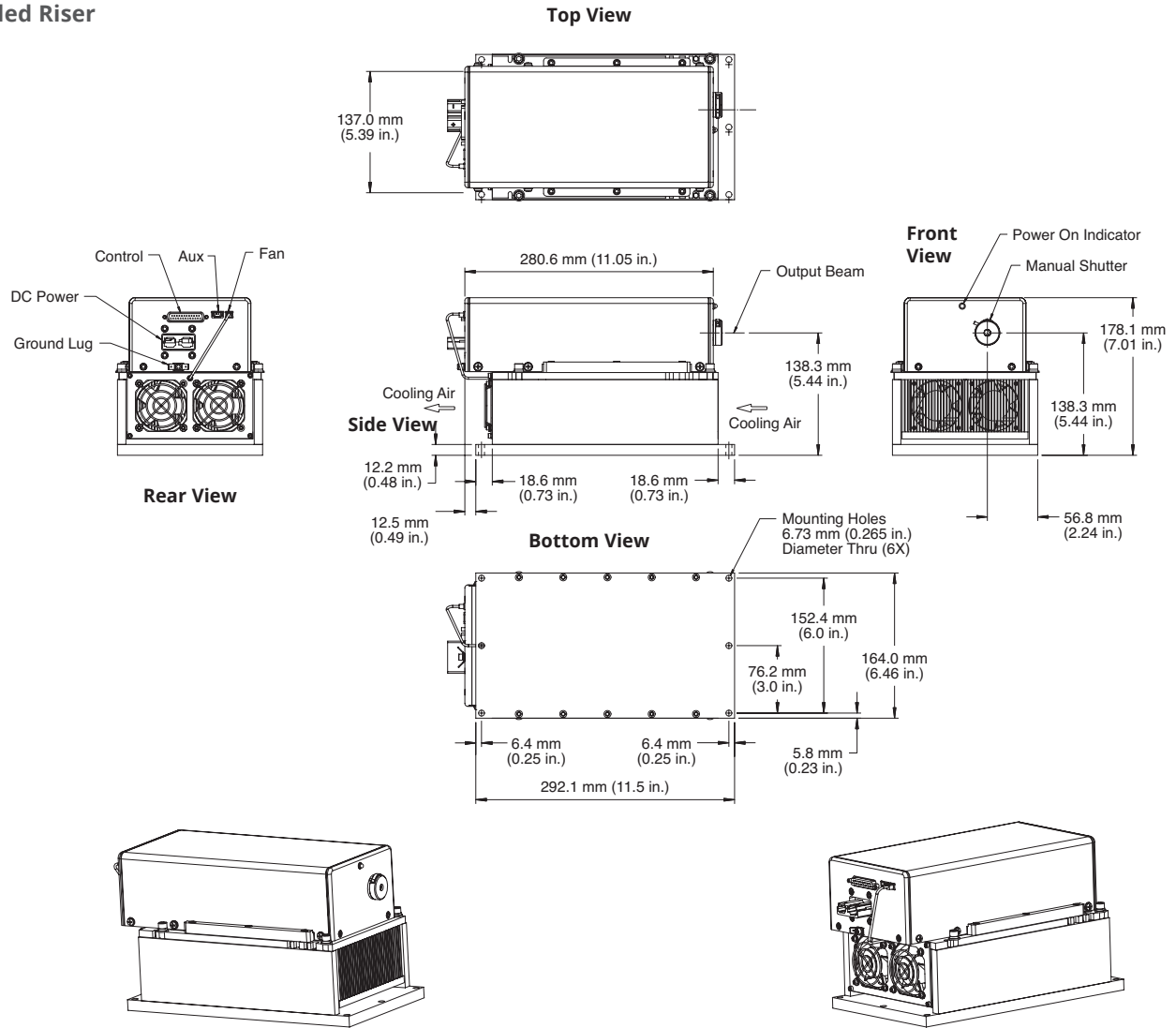

MECHANICAL SPECIFICATIONS

Genesis CX SLM-Series Water-Cooled Riser

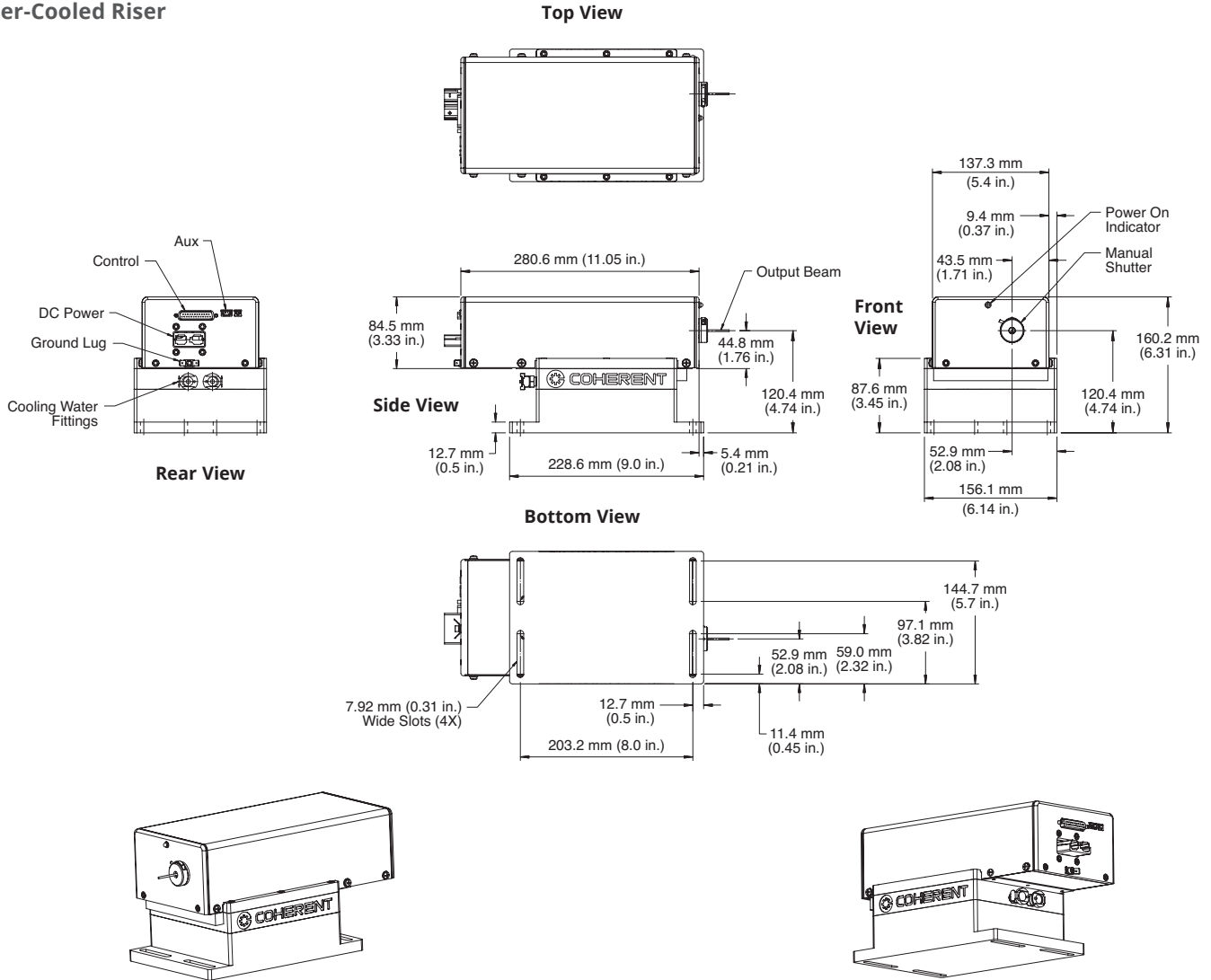

Coherent, Inc.,
5100 Patrick Henry Drive Santa Clara, CA 95054
p. (800) 527-3786 | (408) 764-4983
f. (408) 764-4646

tech.sales@Coherent.com www.Coherent.com

Coherent follows a policy of continuous product improvement. Specifications are subject to change without notice. Coherent's scientific and industrial lasers are certified to comply with the Federal Regulations (21 CFR Subchapter J) as administered by the Center for Devices and Radiological Health on all systems ordered for shipment after August 2, 1976.

Coherent offers a limited warranty for all Genesis CX SLM lasers. For full details of this warranty coverage, please refer to the Service section at www.Coherent.com or contact your local Sales or Service Representative. Printed in the U.S.A. MC-012-12-0M1117Rev.C Copyright ©2017 Coherent, Inc.

