

# PILine® XY Stage

Compact XY Stage with Ultrasonic Piezomotors

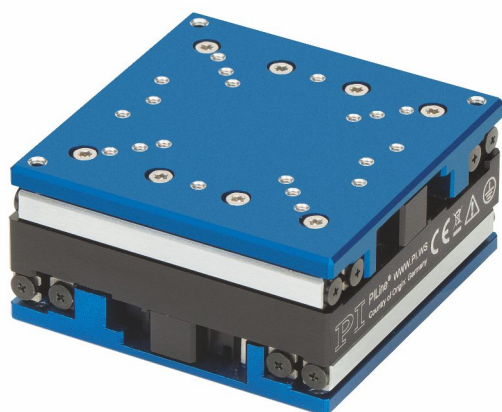

## U-723

- Fast positioning in 2 axes
- Space-saving and light
- Excellent guiding accuracy
- High sensor resolution of 10 nm
- Self-locking, no heat generation at rest
- Low-noise operation

### Precision-class XY stage

PILine® stages are particularly suitable for applications that require fast precision positioning. When switched off, the self-locking drive holds the position of the stage mechanically stable. Energy consumption and heat generation are therefore considerably reduced. Applications with a low duty cycle that are battery-powered or heat-sensitive benefit from these characteristics. The position of the axis is measured by an encoder and an optical reference switch allows reliable repeatable motion. The piezomotor drive principle and its electrical operation is inexpensive and can be customized.

### PILine® ultrasonic piezomotors

An integral part of a PILine® ultrasonic piezomotor is a piezo actuator that is preloaded against a movable, guided runner via a coupling element. The piezoceramic actuator is excited to ultrasonic oscillation by a high-frequency AC voltage between 100 and 200 kHz. Deformation of the actuator leads to periodic diagonal motion of the coupling element relative to the runner. The feed created is a few nanometers per cycle; the high frequencies lead to the high velocities. Preloading the piezoceramic actuator against the runner ensures self-locking of the drive when at rest and switched off.

### Direct position measurement with incremental encoder

Noncontact optical encoders measure the actual position directly at the motion platform with the greatest accuracy so that nonlinearity, mechanical play or elastic deformation have no influence on position measuring.

### Valid patents

US patent no. 6,765,335B2

European patent no. 1267425B1

### Fields of application

Micromanipulation, automation, biotechnology, sample manipulation, sample positioning, applications with limited space, vacuum applications to  $10^{-6}$  hPa (optional)

## Specifications

Preliminary data			
Moving	U-723.25	Unit	Tolerance
Active axes	x, y		
Travel range	22 mm × 22 mm		
Velocity	200	mm/s	max.
Mechanical properties	U-723.25	Unit	Tolerance
Load capacity in z	5	N	max.
Mass without cable	110	g	
Linear guiding	Crossed roller bearing with anti-creep system		
Drive properties	U-723.25	Unit	Tolerance
Drive type	PILine® ultrasonic piezomotor, performance class 1		
Nominal force	2	N	typ.
Holding force	2	N	typ.
Positioning	U-723.25	Unit	Tolerance
Integrated sensor	Optical, incremental sensor		
Sensor resolution	10	nm	
Minimum incremental motion	0.1	μm	typ.
Reference point switch	Direction-sensing optical reference point switch		
Miscellaneous	U-723.25	Unit	Tolerance
Operating temperature range	0 to 40	°C	
Humidity	20 – 90% rel., not condensing		
Material	Aluminum, anodized		
Motor / sensor connection	2 × Sub-D, 15-pin (m)		
Cable length	2 × 1.5 m		

Ask about custom designs!

Technical data specified at room temperature (22±3 °C) with C-867.2U2.

## Drawings and Images

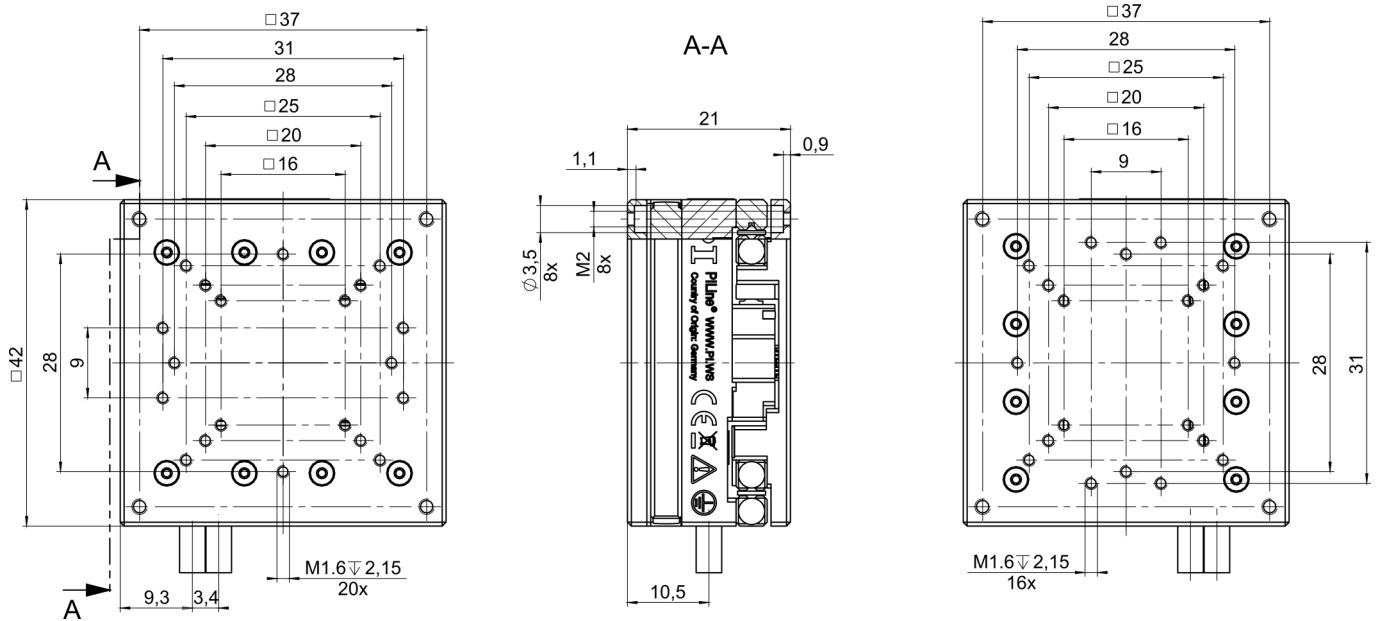

U-723, dimensions in mm

## Ordering Information

### U-723.25

PILine® XY stage, Compact design, 22 mm × 22 mm Travel range