

ECO165LM Series

Mechanical Bearing, Linear-Motor Stage

High-performance in a cost-effective, economic package

Rugged mechanical design

Direct-drive linear motor for precision motion

Eight models with travels from 100 mm to 600 mm

The ECO165LM series, part of the ECO linear stage family, builds upon Aerotech's long tradition of producing low total cost of ownership motion designs. Excellent positioning specifications, high stiffness, and a variety of options and features combined with economic pricing make ECO165LM stages an ideal choice for medium-performance production applications.

Quality Mechanical Construction

A long-life recirculating linear guide bearing system and quality construction make the ECO165LM an attractive solution for applications where uptime is critical. Unlike low-cost competitive motion stages, the ECO165LM can be integrated into complex machines with the assurance it will perform at a high level and outlast other machine components.

Precision Motion Performance

ECO165LM series stages are optimized with high precision, noncontact linear encoders. Precision recirculating linear bearings, along with Aerotech's machining and assembly craftsmanship, enable the best geometric performance per unit price on the market.

The precision noncontact encoders enable minimum incremental motion to 10 nm with micrometer-level repeatability. The optional HALAR factory calibration improves positioning accuracy to $\pm 1.5 \mu\text{m}$.



The ECO165LM-0400 is one of eight models in the ECO165LM series.

Direct-Drive Linear Motor

The ECO165LM comes standard with Aerotech's field-proven linear motor technology. It is available with a high-performance linear-motor option for applications requiring higher force and acceleration motion profiles. In both cases the ironlessforcer coil provides high force with zero cogging for super-smooth velocity and position control. This ironless design is ideal for applications requiring outstanding contour accuracy and smooth velocity profiling. As with all Aerotech linear motor stages, the linear motor has zero backlash, no windup, zero friction, and excellent dynamic responsiveness.

Design and Integration Flexibility

The ECO165LM is available in eight different models with travels ranging from 100 mm to 600 mm and speeds up to 2 m/s. Configurable cable management solutions are available for single and multi-axis systems as standard options.

The base mounting holes are accessible from the outside of the stage for easy mounting. Standard mounting holes for both English and metric optical tables are present in all travels. Tabletops are available with both English and metric mounting patterns. Tabletop hole patterns allow the direct attachment of several types of Aerotech rotary stages.

The ECO165LM stage is a flexible, yet cost-effective, linear motion stage with many options to fit the exact needs of the application. It is easily the best performing and most versatile linear stage per unit price that money can buy.

ECO165LM Series SPECIFICATIONS

Mechanical Specifications		ECO165LM							
Travel		100	150	200	250	300	400	500	600
Accuracy ⁽¹⁾	Standard	±6 µm	±8 µm	±10 µm	±12 µm	±14 µm	±16 µm	±18 µm	±20 µm
	Calibrated	±1.5 µm	±1.5 µm	±2 µm	±2 µm	±2 µm	±2.5 µm	±2.5 µm	±3 µm
Resolution (Min. Incremental Motion)		10 nm							
Bidirectional Repeatability ⁽¹⁾		±0.75 µm	±0.75 µm	±0.75 µm	±0.75 µm	±0.75 µm	±1.0 µm	±1.0 µm	±1.0 µm
Straightness ⁽¹⁾		±3 µm	±4 µm	±5 µm	±6 µm	±7 µm	±9 µm	±11 µm	±13 µm
Flatness ⁽¹⁾		±3 µm	±4 µm	±5 µm	±6 µm	±7 µm	±9 µm	±11 µm	±13 µm
Pitch		40 µrad (8.2 arc sec)	40 µrad (8.2 arc sec)	50 µrad (10.3 arc sec)	55 µrad (11.3 arc sec)	65 µrad (13.4 arc sec)	80 µrad (16.5 arc sec)	95 µrad (19.6 arc sec)	110 µrad (22.7 arc sec)
Roll		40 µrad (8.2 arc sec)	40 µrad (8.2 arc sec)	50 µrad (10.3 arc sec)	55 µrad (11.3 arc sec)	65 µrad (13.4 arc sec)	80 µrad (16.5 arc sec)	95 µrad (19.6 arc sec)	110 µrad (22.7 arc sec)
Yaw		40 µrad (8.2 arc sec)	40 µrad (8.2 arc sec)	50 µrad (10.3 arc sec)	55 µrad (11.3 arc sec)	65 µrad (13.4 arc sec)	80 µrad (16.5 arc sec)	95 µrad (19.6 arc sec)	110 µrad (22.7 arc sec)
Maximum Speed ⁽²⁾		2 m/s							
Maximum Acceleration ⁽²⁾		1.5 g							
Maximum Force, Continuous	M1	36.5 N							
	M2	77.7 N							
Load Capacity ⁽³⁾	Horizontal	45 kg							
	Side	45 kg							
Moving Mass		2.1 kg							
Stage Mass	M1	6.4 kg	7.1 kg	7.7 kg	8.3 kg	9.0 kg	10.3 kg	11.6 kg	12.8 kg
	M2	7.2 kg	8.0 kg	8.8 kg	9.6 kg	10.4 kg	12.0 kg	13.6 kg	15.2 kg
Material		Anodized Aluminum							
MTBF (Mean Time Between Failure)		20,000 Hours							

Notes:

1. Certified with -PL1 option.
2. Requires the selection of an appropriate amplifier with sufficient voltage and current., and is dependent on motor selection.
3. Axis-orientation for on-axis loading is listed.
4. Specifications are for single-axis systems measured 25 mm above the tabletop. Performance of multi-axis systems is payload and workpoint dependent. Contact factory for multi-axis applications.

Electrical Specifications	
Drive System	Brushless Linear Servomotor
Feedback	Noncontact Encoder Incremental – 1 Vpp and TTL (0.1 µm) Output Absolute – EnDat 2.2
Maximum Bus Voltage	320 VDC
Limit Switches	5 V, Normally-Closed
Home Switch	Near Center

Recommended Controller		
Multi-Axis	A3200	Ndrive HLe/Ndrive CP/Ndrive HPe/Npaq
	Ensemble	Ensemble HLe/Ensemble CP/Ensemble HPe
Single Axis	Soloist	Soloist CP/Soloist HPe

ECO165LM Series SPECIFICATIONS

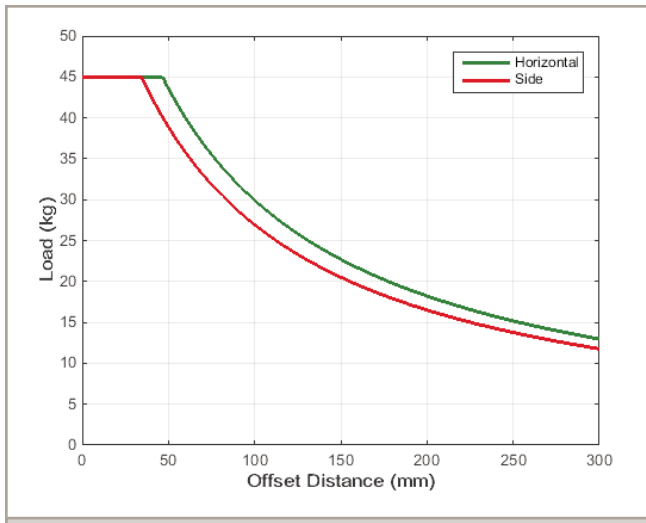

Cantilevered load capability of the ECO165LM.

ECO165LM Series DIMENSIONS

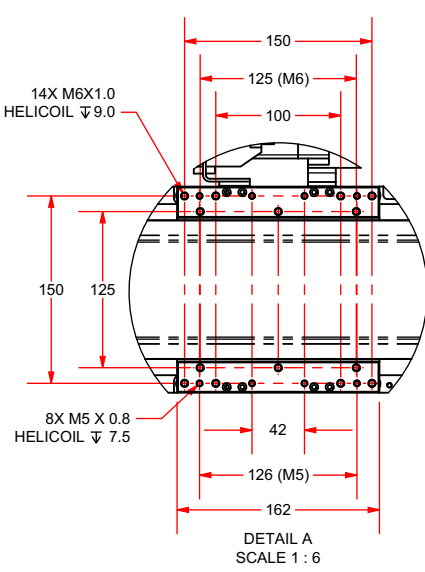
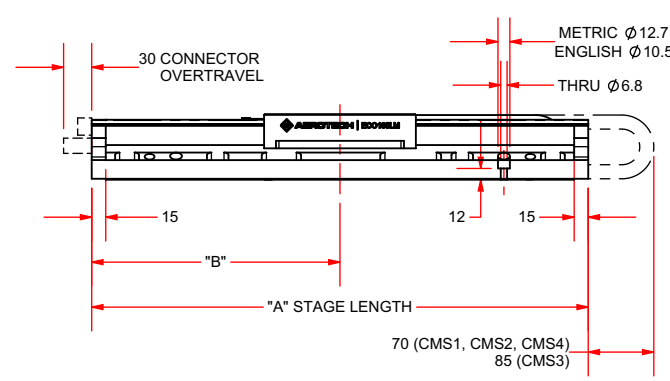
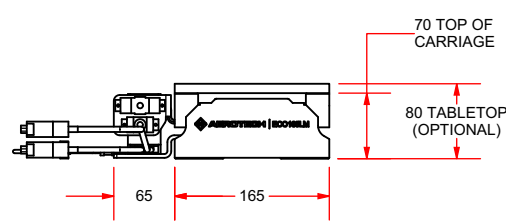
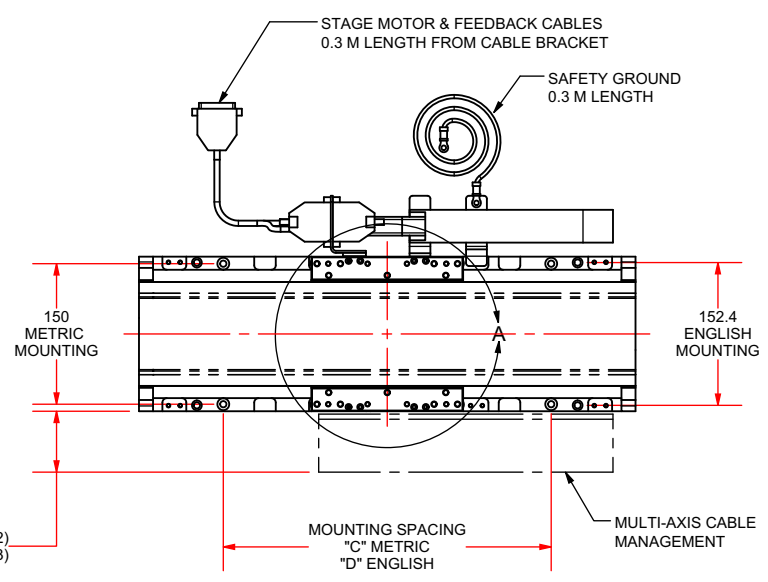
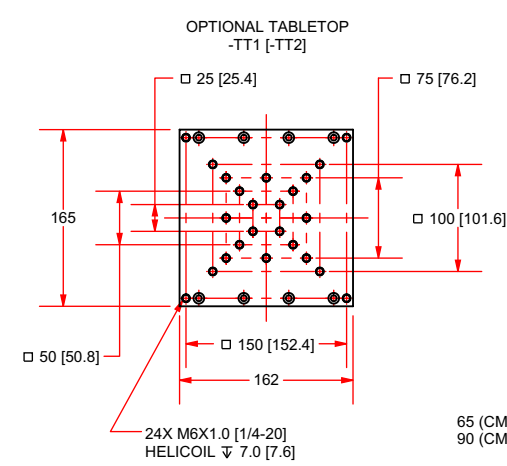
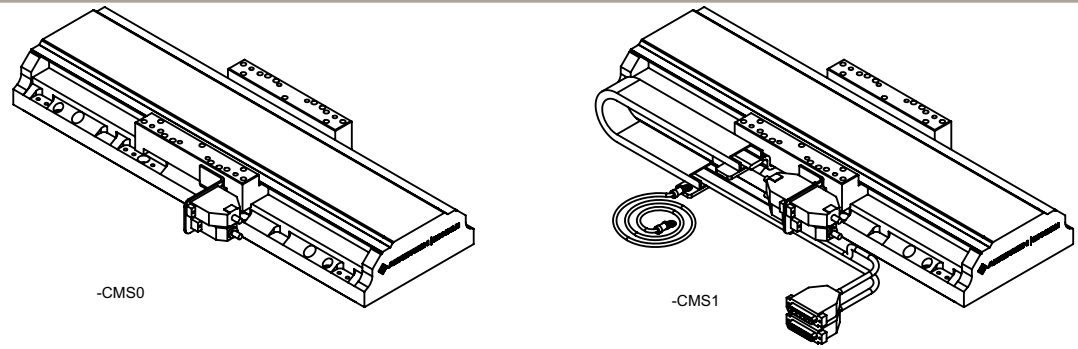

BASIC MODEL	NOMINAL TRAVEL	ELEC LIMIT TRAVEL	MECH LIMIT TRAVEL	A	B	C	D
ECO165LM-0100	100	102-108	125	330	165	150	152.4
ECO165LM-0150	150	152-158	175	380	190	150	152.4
ECO165LM-0200	200	202-208	225	430	215	150, 350	152.4
ECO165LM-0250	250	252-258	275	480	240	150, 350	152.4
ECO165LM-0300	300	302-308	325	530	265	150, 350	152.4, 406.4
ECO165LM-0400	400	402-408	425	630	315	150, 350, 550	152.4, 406.4
ECO165LM-0500	500	502-508	525	730	365	150, 350, 550	152.4, 406.4
ECO165LM-0600	600	602-608	625	830	415	150, 350, 550, 750	152.4, 406.4, 660.4

DIMENSIONS: MILLIMETERS.

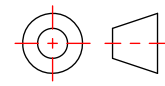

EC0165LM Series Accessory Tabletop DIMENSIONS

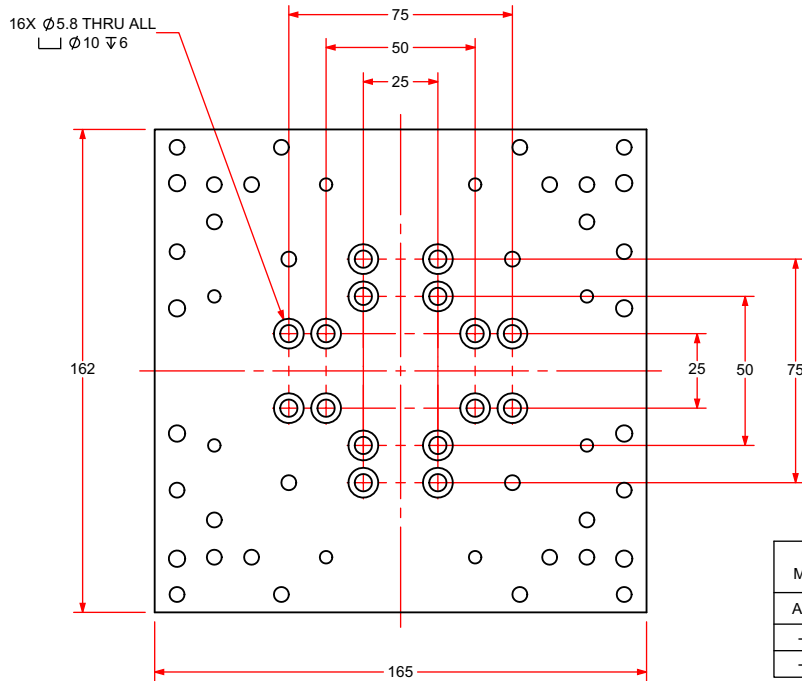
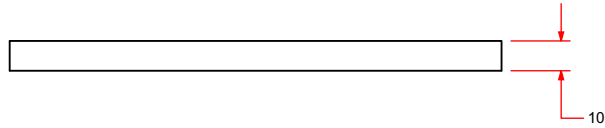
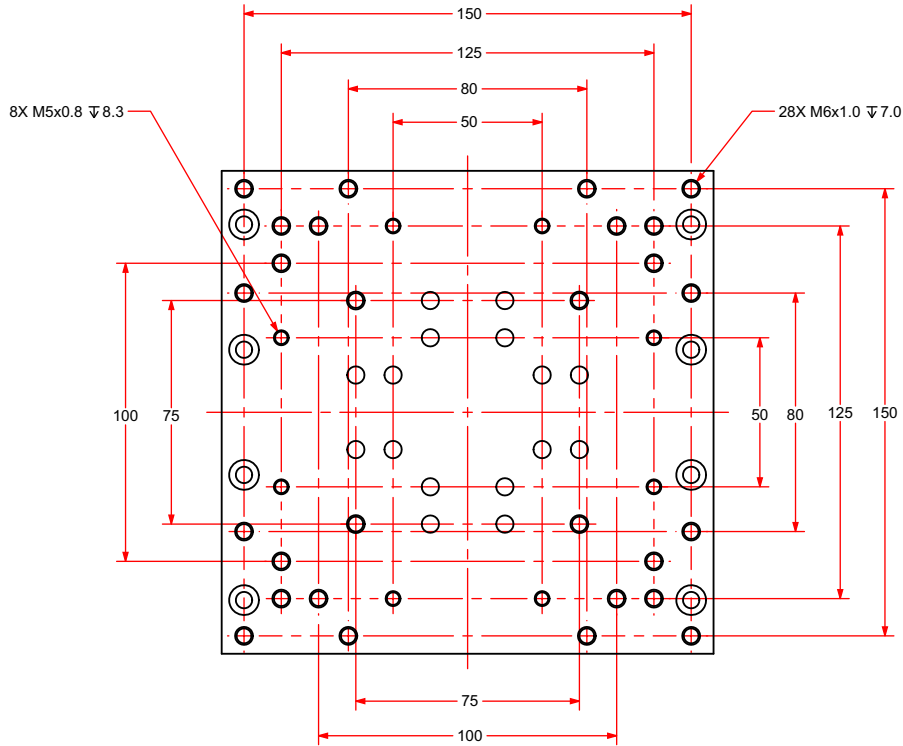

-TT3 MOUNTS THE FOLLOWING		
ADRS	ADRT	AGR
-100		75
-150	-150	100*

*SIDE MOUNT NOT AVAILABLE

DIMENSIONS: MILLIMETERS

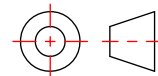

ECO165LM ORDERING INFORMATION

Travel (Required)

-0100	100 mm travel stage
-0150	150 mm travel stage
-0200	200 mm travel stage
-0250	250 mm travel stage
-0300	300 mm travel stage
-0400	400 mm travel stage
-0500	500 mm travel stage
-0600	600 mm travel stage

Motor (Optional)

-M1	Standard motor option
-M2	High performance motor option

Tabletop (Optional)

-TT1	Tabletop with metric dimension mounting
-TT2	Tabletop with English dimension mounting
-TT3	Accessory tabletop with mounting for select rotary stages

Feedback (Required)

-E1	Incremental linear encoder, 1 Vpp
-E2	Incremental linear encoder, 0.1 μ m digital TTL output

Cable Management (Required)

-CMS0	No external CMS, motor/feedback connector bracket on carriage
-CMS1	External CMS for single axis
-CMS2	External CMS for lower-axis of two-axis ECO (XY) assembly
-CMS3	External CMS for lower-axis of two-axis (XZ or XT) assembly
-CMS4	External CMS for upper-axis of two-axis ECO assembly

Lifting Hardware (Optional)

-LF	Lifting hardware
-----	------------------

NOTE: Lifting option only available on travels 400 mm and greater. Lifting should never be ordered on the upper-axis of an XY set (only order on lower-axis).

Metrology (Required)

-PL0	No metrology performance plots
-PL1	Metrology, uncalibrated with performance plots
-PL2	Metrology, calibrated (HALAR) with performance plots

ECO165LM ORDERING INFORMATION

Integration (Required)

Aerotech offers both standard and custom integration services to help you get your system fully operational as quickly as possible. The following standard integration options are available for this system. Please consult Aerotech if you are unsure what level of integration is required, or if you desire custom integration support with your system.

-TAS	<p>Integration - Test as system</p> <p>Testing, integration, and documentation of a group of components as a complete system that will be used together (ex: drive, controller, and stage). This includes parameter file generation, system tuning, and documentation of the system configuration.</p>
-TAC	<p>Integration - Test as components</p> <p>Testing and integration of individual items as discrete components. This is typically used for spare parts, replacement parts, or items that will not be used or shipped together (ex: stage only). These components may or may not be part of a larger system.</p>

Accessories (to be ordered as a separate line item)

ALIGN-NPA	Non-precision XY assembly
ALIGN-NPAZ	Non-precision XZ or YZ assembly
ALIGN-PA10	XY assembly; 10 arc sec orthogonality. Alignment to within 7 microns orthogonality for short travel stages.
ALIGN-PA10Z	XZ or YZ assembly with L-bracket; 10 arc second orthogonality. Alignment to within 10 microns orthogonality for short travel stages.
ALIGN-PA5	XY assembly; 5 arc sec orthogonality. Alignment to within 3 microns orthogonality for short travel stages.
ALIGN-PA5Z	XZ or YZ assembly with L-bracket; 5 arc second orthogonality. Alignment to within 5 microns orthogonality for short travel stages.