

ALS1000 Series

Mechanical Bearing, Linear Motor Stage

Direct-drive linear motor for ultra-precise motion

Long-life linear motion guide bearing system

2-axis internal cable management system

Sealed design with optional air purge

Low-cost, small footprint, high-performance stage

The ALS1000 is a compact, high-performance stage that is as accurate as it is versatile. It provides a small cross section, large payload capacity, cost-effective solution for precision applications where a small footprint and environmental protection are required. A linear motion guide bearing system, two-axis internal cable management, and high-performance brushless servomotor make the ALS1000 the stage of choice in industrial applications such as laser machining, medical component manufacturing, and other applications requiring high accuracy in a production environment.

Construction Features

Sealed linear motion guide bearings with integral wipers are incorporated to provide excellent payload capability and long life. Both the metal waycover and tabletop are treated with a hardcoat (Rockwell 62 hardness) that is scratch-resistant and provides outstanding protection in the harshest applications. An optional air-purge fitting is available that allows air to be forced into the body of the stage to create a positive internal pressure that resists particulates from entering the stage. The tabletop utilizes stainless steel Helicoil™ inserts to protect mounting holes against thread wear.

Linear Motor Drive

Aerotech's high-power, cog-free, BLMC series linear motor drives the ALS1000. The non-magnetic forcer coil provides high force with zero cogging for super-smooth velocity and position control. This zero cogging design is ideal for applications requiring outstanding contour accuracy and smooth velocity profiling. As with all of



The ALS1000 stages in an XY assembly

Aerotech's ALS series linear motor stages, the linear motor has zero backlash, no windup, zero friction, and outstanding system responsiveness.

Cable Management System

The ALS1000 features an optimized cable management system (CMS) that is designed for millions of cycles of maintenance-free operation. In single- and two-axis systems, the CMS is completely internal. External CMS is available for three-axis systems.

High Performance

Noncontact linear encoders are standard on all ALS1000 series stages. Either a line-driver output or amplified sine-wave output encoder is available. Motor power and feedback signals terminate in the stage endplate, allowing for a simple, clean interface.

The optional HALAR factory calibration further increases the standard accuracy and repeatability. Aerotech manufactures a wide range of matching drives and controls to provide a fully integrated and optimized motion solution.

ALS1000 Series SPECIFICATIONS

ALS1000 Series	ALS1000-100	ALS1000-150	ALS1000-200	ALS1000-300	ALS1000-450	
Total Travel	100 mm	150 mm	200 mm	300 mm	450 mm	
Drive System	Linear brushless servomotor					
Bus Voltage	Up to 80 VDC					
Continuous Current	A_{pk}	Up to 4.20 A				
	A_{rms}	Up to 2.97 A				
Resolution	0.005 μ m - 1.0 μ m					
Maximum Travel Speed⁽¹⁾	750 mm/s					
Maximum Linear Acceleration	2 g - 20 m/s ² (no load)					
Maximum Load⁽²⁾	Horizontal	50.0 kg				
	Side	25.0 kg				
Accuracy	Uncalibrated	$\pm 4.0 \mu$ m	$\pm 6.0 \mu$ m	$\pm 8.0 \mu$ m	$\pm 12.0 \mu$ m	$\pm 18.0 \mu$ m
	Calibrated⁽³⁾	$\pm 1.0 \mu$ m				
Repeatability	$\pm 1.0 \mu$ m					
Straightness and Flatness	Differential	3.0 μ m/25 mm				
	Max Deviation	$\pm 2.4 \mu$ m	$\pm 3.6 \mu$ m	$\pm 4.8 \mu$ m	$\pm 7.2 \mu$ m	$\pm 10.8 \mu$ m
Pitch and Yaw	6 arc sec	9 arc sec	12 arc sec	16 arc sec	20 arc sec	
Nominal Stage Weight	8.4 kg	10.0 kg	11.0 kg	13.1 kg	16.0 kg	
Construction	Aluminum body/Black anodize finish/Hardcoat					

Notes:

1. Maximum speed based on stage capability. Maximum application velocity may be limited by system data rate and system resolution.
2. Maximum load based on bearing capability. Maximum application load may be limited by acceleration requirements.
3. Available with Aerotech controllers.
4. Specifications are for single-axis systems, measured 25 mm above the tabletop. Performance of multi-axis systems is payload and workpoint dependent. Consult factory for multi-axis or non-standard applications.

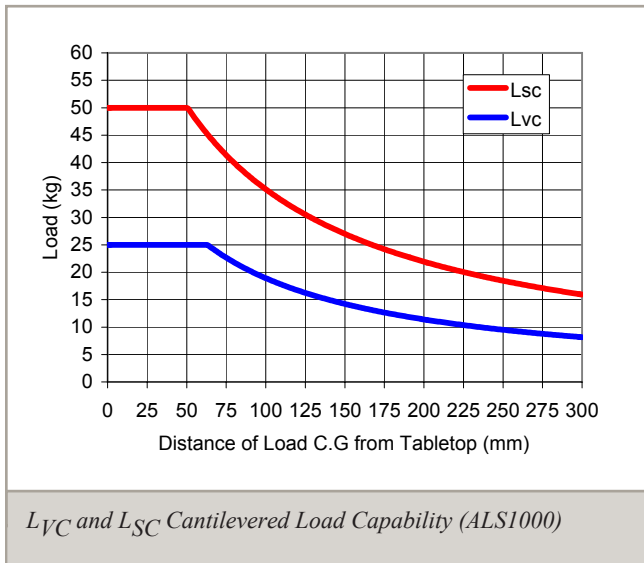

ALS1000 Series DIMENSIONS

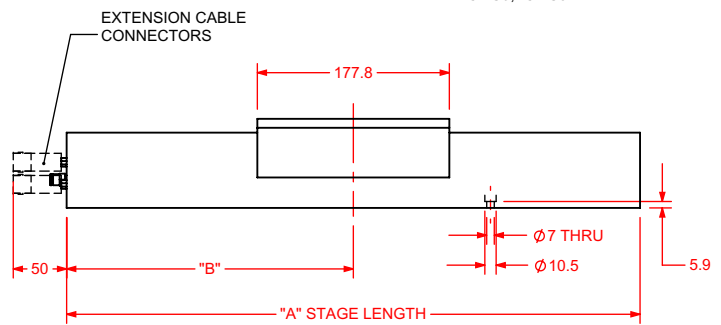
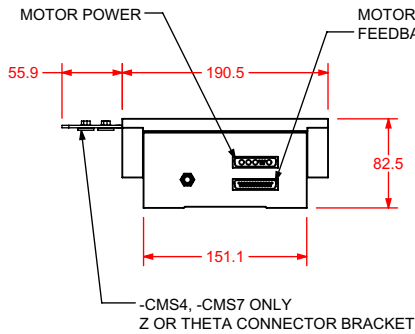
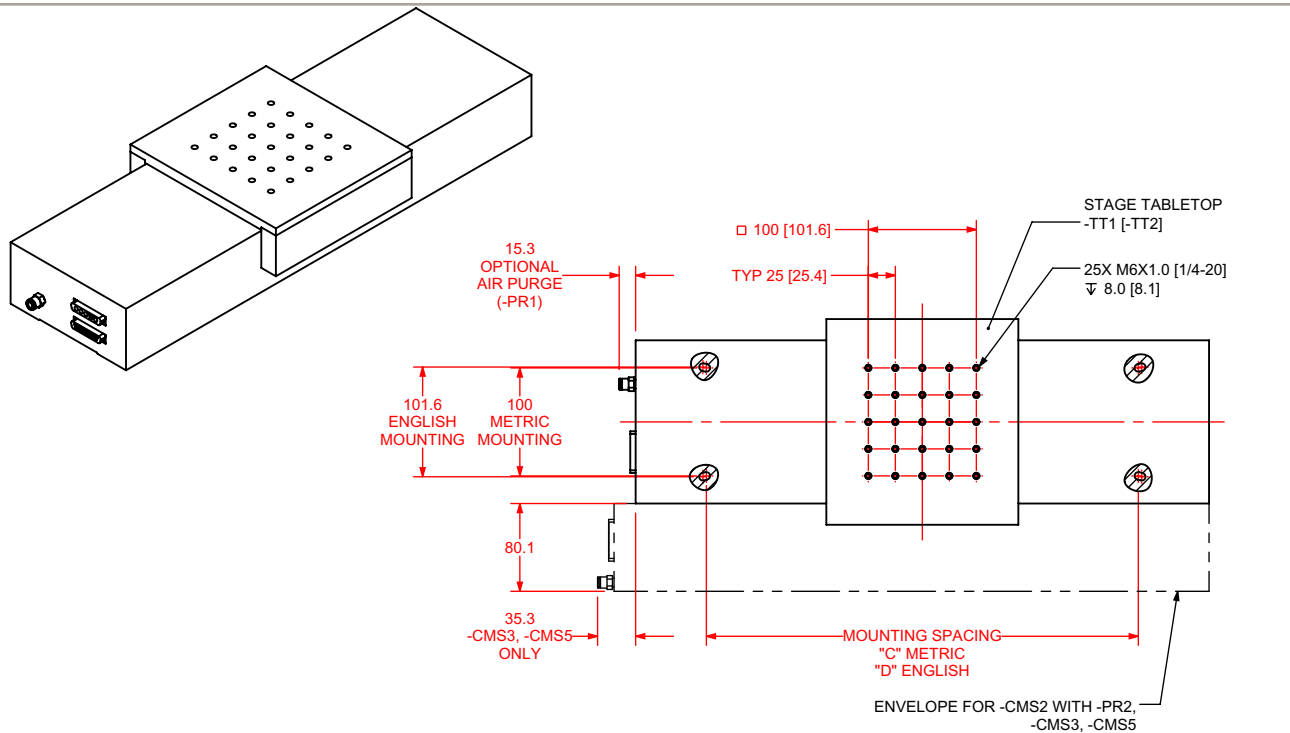

XY STACK (-CMS3 SHOWN)

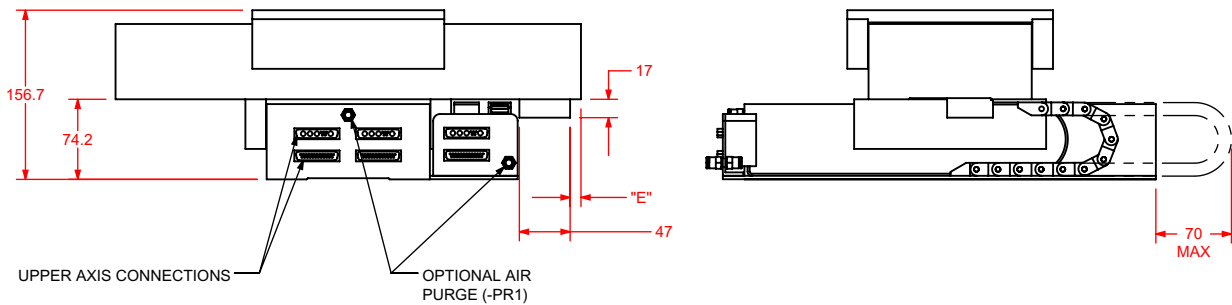

BASIC MODEL	NOMINAL TRAVEL	ELEC LIMIT TRAVEL	MECH LIMIT TRAVEL	A	B	C	D	E
ALS1000-100	100	102-108	127.8	331	165.5	100, 250	101.6, 254	7.4
ALS1000-150	150	152-158	177.8	381	190.5	100, 250	101.6, 254	10.1
ALS1000-200	200	202-208	227.8	431	215.5	100, 250	101.6, 254	10.1
ALS1000-300	300	302-308	327.8	531	265.5	100, 250, 400	101.6, 254, 406.4	10.1
ALS1000-450	450	452-458	477.8	681	340.5	100, 250, 400, 550	101.6, 254, 406.4, 711.2	10.1

DIMENSIONS: MILLIMETERS

ALS1000 Series ORDERING INFORMATION

Travel (Required)

-100	100 mm travel
-150	150 mm travel
-200	200 mm travel
-300	300 mm travel
-450	450 mm travel

Feedback (Required)

-E1	Linear encoder, amplified sine output, 1 Vpp
-E2	Linear encoder, 1 μ m digital TTL output

Cable Management (Required)

-CMS1	Single axis, internal cable management system
-CMS2	Cable management system for ALS XY assembly, lower axis, internal CMS
-CMS3	Cable management system for ALS XY assembly, lower axis, external CMS
-CMS4	Cable management system for non-ALS XZ assembly, lower axis, internal CMS
-CMS5	Cable management system for XYZ assembly, lower axis, external CMS
-CMS6	Cable management system for Y assembly, upper axis, internal CMS
-CMS7	Cable management system for YXZ assembly, middle axis, internal CMS

Tabletop (Optional)

-TT1	Tabletop with metric dimension mounting pattern and holes
-TT2	Tabletop with English dimension mounting pattern and holes

Home Marker (Required)

-HM1	Home marker located at stage center
-HM2	Home marker located at counter-clockwise end of travel
-HM3	Home marker located at clockwise end of travel

Air Purge (Optional)

-PR1	Air purge for X or single axis
-PR2	Air purge for Y axis

Home Marker Location

-CM	Home marker located at the center of the stage
-CCWM	Home marker located at the counterclockwise end of the stage
-CWM	Home marker located at the clockwise end of the stage

Metrology (Required)

-PL1	Metrology, uncalibrated with performance plots
-PL2	Metrology, calibrated (HALAR) with performance plots

Integration (Required)

Aerotech offers both standard and custom integration services to help you get your system fully operational as quickly as possible. The following standard integration options are available for this system. Please consult Aerotech if you are unsure what level of integration is required, or if you desire custom integration support with your system.

-TAS	<p>Integration - Test as system</p> <p>Testing, integration, and documentation of a group of components as a complete system that will be used together (ex: drive, controller, and stage). This includes parameter file generation, system tuning, and documentation of the system configuration.</p>
-TAC	<p>Integration - Test as components</p> <p>Testing and integration of individual items as discrete components. This is typically used for spare parts, replacement parts, or items that will not be used or shipped together (ex: stage only). These components may or may not be part of a larger system.</p>