

Z Axis Aluminum Crossed Roller Translation Stages (Vertical)

Stage Size 40 × 40 mm / 60 × 60 mm / 65 × 65 mm / 80 × 80 mm

TAM-3L

RoHS

Light-weight Z axis aluminum stages with integrated angle bracket.
Crossed roller guide enable smooth travel.



Application Systems

Optics & Optical Coatings

Opto-Mechanics

Bases

Manual Stages

Actuators & Adjusters

Motorized Stages

Light Sources & Laser Safety

Index

Guide

X Axis Stages

XY Axis Stages

Z Axis Stages

XZ Axis Stages

XYZ Axis Stages

Rotation Stages

Goniometer

Tilt Stages

Vacuum

Ball Bearing Guide

Crossed Roller

Dovetail

Lapping

V Groove Screw

Others

15 × 15 mm

25 × 25 mm

40 × 40 mm

60 × 60 mm

65 × 65 mm

80 × 80 mm

100 × 100 mm

120 × 120 mm

Others

Specifications

Part Number	METRIC	TAM-403L	TAM-603L	TAM-653L-M6	TAM-803L
	INCH	TAM-403LUU	—	TAM-653LUU	—
(Opposite Model)	METRIC	TAM-403RL	—	TAM-653RL-M6	—
	INCH	TAM-403RLUU	—	TAM-653RLUU	—
Stage Size [mm]		40×40	60×60	65×65	80×80
Axes of Travel		Z axis			
Travel [mm]		±6.5	±6.5	±6.5	±7.5
Lead of Actuator [mm/rotation]		0.5	0.5	0.5	0.5
Micrometer Readable Resolution [mm]		0.01	0.01	0.01	0.01
Guide Method		Crossed roller			
Primary Material		Aluminum			
Finish		Black anodized			
Load Capacity [N]		49 (5.0kgf)	49 (5.0kgf)	49 (5.0kgf)	49 (5.0kgf)
Travel Accuracy	Straightness [μm]	2	2	2	2
Max. Moment Capacity	Pitch [N·m]	3.0	5.0	5.0	7.0
	Roll [N·m]	3.0	5.0	5.0	7.0
Moment Stiffness	Pitch [°/N·cm]	0.66	0.3	0.3	0.12
Running Parallelism [μm]		20	20	20	20
Squareness [μm]		30	30	30	30
Options		FP ¹ /DM/WP	FP ¹ /DM/WP	FP ¹ /DM/WP	FP ²
Weight [kg]		0.15	0.3	0.4	0.6

Option

Option Code	Compatible product		Lead of Actuator [mm/rotation]	Micrometer Readable Resolution [mm]	Reference
	Products Name	Part Number			
FP	Fine-pitch Screw Adjusters	FPSA-62540 ¹ FPSA-62550 ²	0.25	—	E008
DM	Differential Micrometer Heads	MHF2-13F	Coars: 0.5 Fine: 0.025	Coars: 0.01 Fine: 0.0005	
WP	Sub-micron Worm Drive Micrometer Heads	WGP-13	Coars: 0.25 Fine: 0.005	Coars: 0.005 Fine: 0.0005	

* Please add an option code as the part number suffix to specify various optional specifications.



Outline Drawing

TAM-403L/403LUU

Hexagonal socket head cap screw M3×10...2 screws
Hexagonal socket head cap screw 6-32UNC×3/8...2 screws (UU)

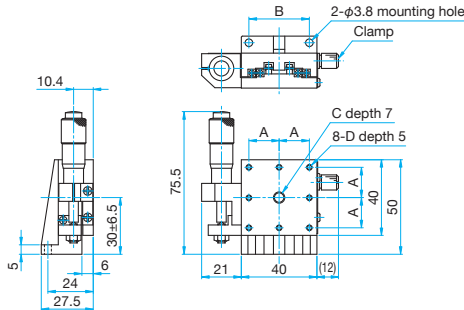

Part Number	A (mm)	B (mm)	C	D
TAM-403L	16	32	M6 P1	M3
TAM-403LUU	15.875	31.75	1/4-20UNC	6-32UNC

TAM-403RL/403RLUU

Hexagonal socket head cap screw M3×10...2 screws
Hexagonal socket head cap screw 6-32UNC×3/8...2 screws (UU)

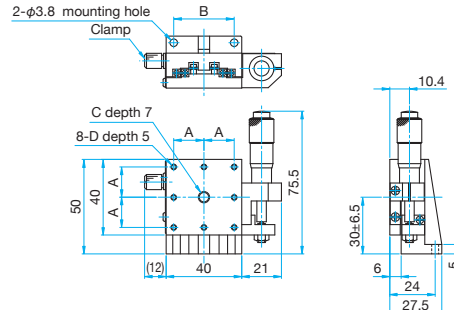

Part Number	A (mm)	B (mm)	C	D
TAM-403RL	16	32	M6 P1	M3
TAM-403RLUU	15.875	31.75	1/4-20UNC	6-32UNC

TAM-603L

Hexagonal socket head cap screw M4×12...4 screws

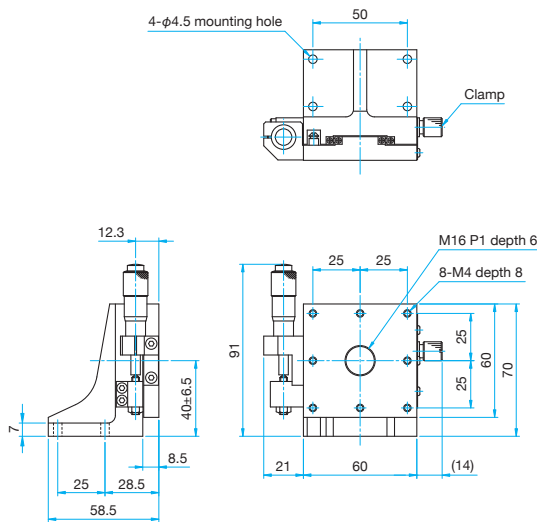

TAM-803L

Hexagonal socket head cap screw M4×12...4 screws

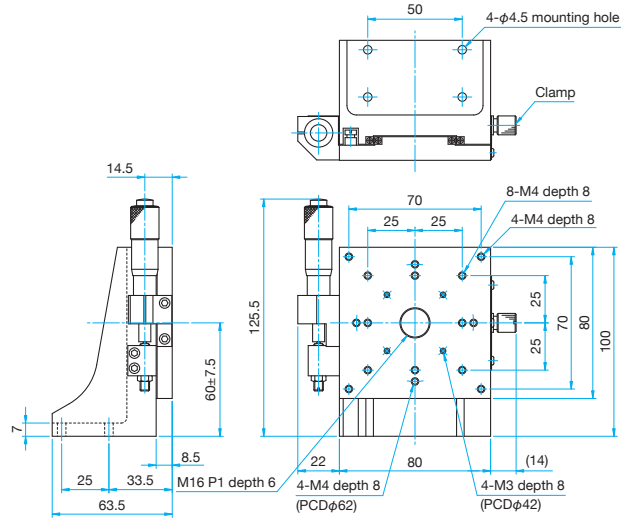

TAM-653L-M6/653LUU

Hexagonal socket head cap screw M6×15...4 screws (M6)
Hexagonal socket head cap screw 1/4-20UNC×5/8...4 screws (UU)

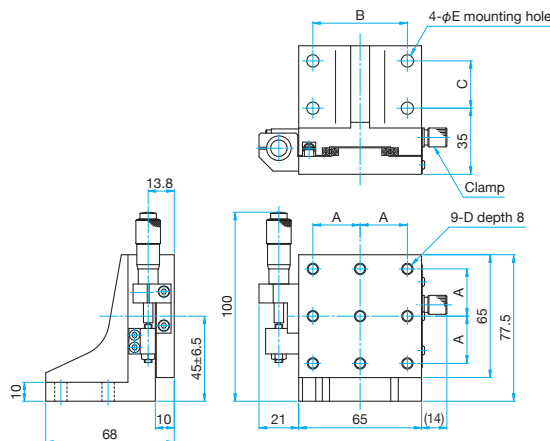

Part Number	A (mm)	B (mm)	C (mm)	D	E (mm)
TAM-653L-M6	25	50	25	M6 P1	6.5
TAM-653LUU	25.4	50.8	25.4	1/4-20UNC	7

TAM-653RL-M6/653RLUU

Hexagonal socket head cap screw M6×15...4 screws (M6)
Hexagonal socket head cap screw 1/4-20UNC×5/8...4 screws (UU)

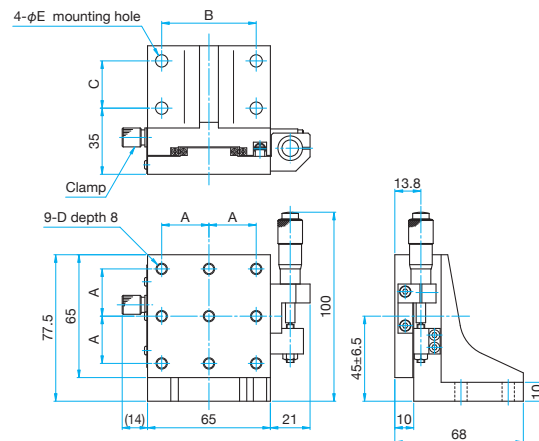

Part Number	A (mm)	B (mm)	C (mm)	D	E (mm)
TAM-653RL-M6	25	50	25	M6 P1	6.5
TAM-653RLUU	25.4	50.8	25.4	1/4-20UNC	7

Application Systems

Optics & Optical Coatings

Opto-Mechanics

Bases

Manual Stages

Actuators & Adjusters

MotORIZED Stages

Light Sources & Laser Safety

Index

Guide

X Axis Stages

XY Axis Stages

Z Axis Stages

XZ Axis Stages

XYZ Axis Stages

Rotation Stages

Goniometer

Tilt Stages

Vacuum

Ball Bearing Guide

Crossed Roller

Dovetail

Lapping

V Groove Screw

Ohters

15 × 15 mm

25 × 25 mm

40 × 40 mm

60 × 60 mm

65 × 65 mm

80 × 80 mm

100 × 100 mm

120 × 120 mm

Others