

XZ Axis Steel Extended Contact Translation Stages

TSD-254 Stage Size 25 x 25 mm

RoHS

TSD-404 Stage Size 40 x 40 mm

RoHS

This XZ assembly incorporates an (X) axis steel linear stage and a (Z) vertical axis steel stage with a horizontal flat top plate.

There are options for micrometer position and fine pitch screws.



Guide

- ▶ Vacuum-compatible stainless steel stages (TSDS-254/404) are also available. [Reference](#) E212 [Catalog Code](#) W7064

Attention

- ▶ This translation stage type is not suitable for inverted use. In this condition, all load would be pulling against the spring.
- ▶ These stages use a pivot mechanism to transfer horizontal motion to vertical motion. This mechanism induces a small non-linearity between the distance the micrometer moves and the distance the stage platform moves. Contact our Sales Division for more information.

Specifications

Guide	METRIC	TSD-254C	TSD-254S	TSD-404C	TSD-404S	
	Part Number	INCH	—	—	TSD-404CUU	TSD-404SUU
X Axis Stages	(Opposite Model)	METRIC	—	TSD-254SR	—	
		INCH	—	—	—	TSD-404SRU
XY Axis Stages	Stage Size [mm]	25×25	25×25	40×40	40×40	
Z Axis Stages	Axes of Travel	XZ axis				
XZ Axis Stages	Micrometer Position	Center	Side	Center	Side	
XYZ Axis Stages	Travel [mm]	X axis ±3 Z axis ±3	X axis ±3 Z axis ±3	X axis ±6.5 Z axis ±3	X axis ±6.5 Z axis ±3	
Rotation Stages	Lead of Actuator [mm/rotation]	0.5	0.5	0.5	0.5	
	Micrometer Readable Resolution [mm]	0.01	0.01	0.01	0.01	
Goniometer	Guide Method	Extended contact ball bearing guide				
	Primary Material	Steel				
Tilt Stages	Finish	Super black chrome + Black matte				
Vacuum	Load Capacity [N]	29.4 (3.0kgf)	29.4 (3.0kgf)	88.3 (9.0kgf)	88.3 (9.0kgf)	
	Travel Accuracy	Straightness [μm]	5	5	2.5	2.5
	Max. Moment Capacity	Pitch [N·m]	1.0	1.0	3.9	3.9
		Roll [N·m]	1.0	1.0	3.9	3.9
Ball Bearing Guide	Moment Stiffness	Pitch [°/N·cm]	8.95	8.95	2.14	2.14
		Roll [°/N·cm]	8.75	8.75	2.04	2.04
Crossed Roller	Parallelism [μm]	110	110	110	110	
Dovetail	Options	FP	FP	FP	FP	
Lapping	Weight [kg]	0.17	0.17	0.45	0.45	

Option for □25mm

Option Code	Compatible product		Lead of Actuator [mm/rotation]	Micrometer Readable Resolution [mm]	Reference
	Products Name	Part Number			
FP	Fine-pitch Screw Adjusters	FPSA-42525	0.25	—	E008

Option for □40mm

Option Code	Compatible product		Lead of Actuator [mm/rotation]	Micrometer Readable Resolution [mm]	Reference
	Products Name	Part Number			
FP	Fine-pitch Screw Adjusters	X axis: FPSA-62540 Z axis: FPSA-42525	0.25	—	E008

* Please add an option code as the part number suffix to specify various optional specifications.

* The load capacity of the FP type is 39.2N (4.0kgf). (40 × 40mm)

* The FP type requires a hex wrench or the optional hex wrench with knob (KCL) for driving operation. [Reference](#) F010 [Catalog Code](#) W8008

Application Systems

Optics & Optical Coatings

Opto-Mechanics

Bases

Manual Stages

Actuators & Adjusters

Motorized Stages

Light Sources & Laser Safety

Index

Guide

X Axis Stages

XY Axis Stages

Z Axis Stages

XZ Axis Stages

XYZ Axis Stages

Rotation Stages

Goniometer

Tilt Stages

Vacuum

Ball Bearing Guide

Crossed Roller

Dovetail

Lapping

V Groove Screw

Others

15 × 15 mm

25 × 25 mm

40 × 40 mm

60 × 60 mm

65 × 65 mm

80 × 80 mm

100 × 100 mm

120 × 120 mm

Others



Outline Drawing

TSD-254C Hexagonal socket head cap screw M2×4...4 screws

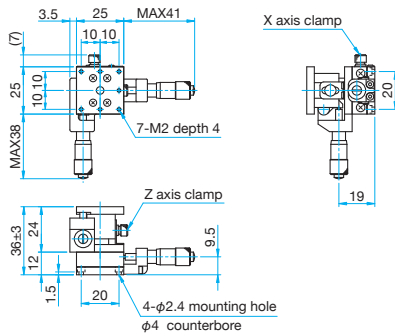

TSD-254S Hexagonal socket head cap screw M2×4...4 screws

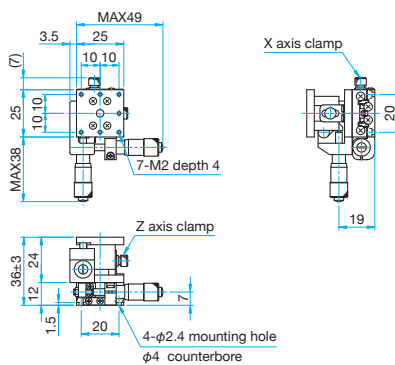

TSD-254SR Hexagonal socket head cap screw M2×4...4 screws

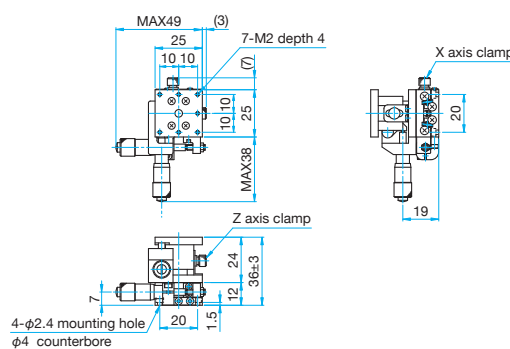

TSD-404C/404CUU Hexagonal socket head cap screw M3×6...4 screws, Spring washers
Hexagonal socket head cap screw 6-32UNC×3/16...4 screws (UU)

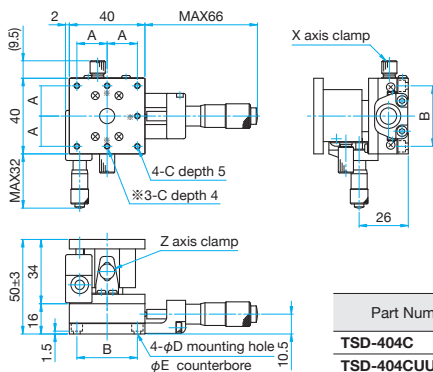

Part Number	A (mm)	B (mm)	C	D (mm)	E (mm)
TSD-404C	16	32	M3	3.5	6
TSD-404CUU	15.875	31.75	6-32UNC	4	6.5

TSD-404S/404SUU Hexagonal socket head cap screw M3×6...4 screws, Spring washers
Hexagonal socket head cap screw 6-32UNC×3/16...4 screws (UU)

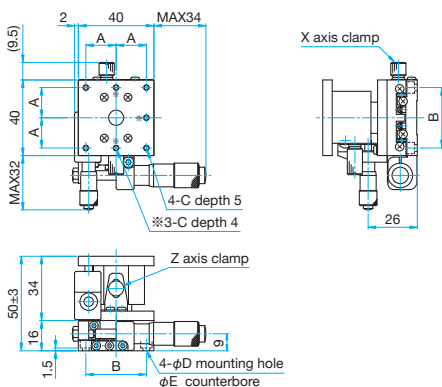

Part Number	A (mm)	B (mm)	C	D (mm)	E (mm)
TSD-404S	16	32	M3	3.5	6
TSD-404SUU	15.875	31.75	6-32UNC	4	6.5

TSD-404SR/404SRUU Hexagonal socket head cap screw M3×6...4 screws, Spring washers
Hexagonal socket head cap screw 6-32UNC×3/16...4 screws (UU)

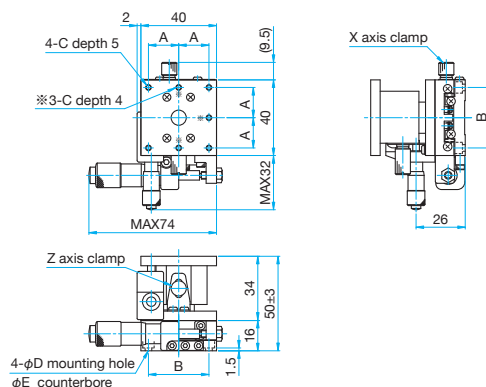

Part Number	A (mm)	B (mm)	C	D (mm)	E (mm)
TSD-404SR	16	32	M3	3.5	6
TSD-404SRUU	15.875	31.75	6-32UNC	4	6.5

Application Systems

Optics & Optical Coatings

Opto-Mechanics

Bases

Manual Stages

Actuators & Adjusters

MotORIZED Stages

Light Sources & Laser Safety

Index

Guide

X Axis Stages

XY Axis Stages

Z Axis Stages

XZ Axis Stages

XYZ Axis Stages

Rotation Stages

Goniometer

Tilt Stages

Vacuum

Ball Bearing Guide

Crossed Roller

Dovetail

Lapping

V Groove Screw

Ohters

15 × 15 mm

25 × 25 mm

40 × 40 mm

60 × 60 mm

65 × 65 mm

80 × 80 mm

100 × 100 mm

120 × 120 mm

Others