

XYZ Axis Steel Extended Contact Translation Stages

TSD-805 Stage Size 80 x 80 mm

TSD-1005 Stage Size 100 x 100 mm

RoHS

RoHS

This XYZ assembly incorporates an integrated (XY) axis steel linear stage and a (Z) vertical axis steel stage with a horizontal flat top plate.

There are options for micrometer position and fine pitch screws.

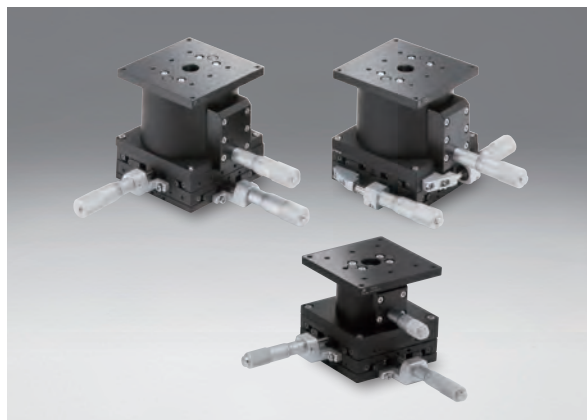

Attention

- ▶ This translation stage type is not suitable for inverted use. In this condition, all load would be pulling against the spring.
- ▶ These stages use a pivot mechanism to transfer horizontal motion to vertical motion. This mechanism induces a small non-linearity between the distance the micrometer moves and the distance the stage platform moves. Contact our Sales Division for more information.

Specifications

Part Number	METRIC	TSD-805C	TSD-805S	TSD-1005C	TSD-1005S
(Opposite Model)	METRIC		TSD-805SR	—	TSD-1005SR
Stage Size [mm]		80×80	80×80	100×100	100×100
Axes of Travel		XYZ axis			
Micrometer Position		Center	Side	Center	Side
Travel [mm]		XY axis ±12.5 Z axis ±5	XY axis ±12.5 Z axis ±5	XY axis ± 12.5 Z axis ±10	XY axis ±12.5 Z axis ±10
Lead of Actuator [mm/rotation]		0.5	0.5	0.5	0.5
Micrometer Readable Resolution [mm]		0.01	0.01	0.01	0.01
Guide Method		Extended contact ball bearing guide			
Primary Material		Steel			
Finish		Super black chrome + Black matte			
Load Capacity [N]		147 (15.0kgf)	147 (15.0kgf)	245 (25.0kgf)	245 (25.0kgf)
Travel Accuracy	Straightness [μm]	2.5	2.5	2.5	2.5
Max. Moment Capacity	Pitch [N·m]	6.9	6.9	9.8	9.8
	Roll [N·m]	6.9	6.9	9.8	9.8
Moment Stiffness	Pitch [°/N·cm]	0.67	0.67	0.45	0.45
	Roll [°/N·cm]	0.67	0.67	0.45	0.45
Parallelism [μm]		130	130	150	150
Options		FP	FP	FP	FP
Weight [kg]		2.6	2.6	6.1	6.1

Option for □80mm

Option Code	Compatible product		Lead of Actuator [mm/rotation]	Micrometer Readable Resolution [mm]	Reference
	Products Name	Part Number			
FP	Fine-pitch Screw Adjusters	XY axis: FPSA-62550 X axis: FPSA-62540	0.25	—	E008

Option for □100mm

Option Code	Compatible product		Lead of Actuator [mm/rotation]	Micrometer Readable Resolution [mm]	Reference
	Products Name	Part Number			
FP	Fine-pitch Screw Adjusters	FPSA-62555	0.25	—	E008

* Please add an option code as the part number suffix to specify various optional specifications.

* The load capacity of the FP type is 39.2N (4.0kgf).

* The FP type requires a hex wrench or the optional hex wrench with knob (KCL) for driving operation. Reference F010 Catalog Code W8008

Application Systems

Optics & Optical Coatings

Opto-Mechanics

Bases

Manual Stages

Actuators & Adjusters

Motorized Stages

Light Sources & Laser Safety

Index

Guide

X Axis Stages

XY Axis Stages

Z Axis Stages

XZ Axis Stages

XYZ Axis Stages

Rotation Stages

Goniometer

Tilt Stages

Vacuum

Ball Bearing Guide

Crossed Roller

Dovetail

Lapping

V Groove Screw

Others

15 × 15 mm

25 × 25 mm

40 × 40 mm

60 × 60 mm

65 × 65 mm

80 × 80 mm

100 × 100 mm

120 × 120 mm

Others



Outline Drawing

TSD-805C Hexagonal socket head cap screw M4x8...4 screws

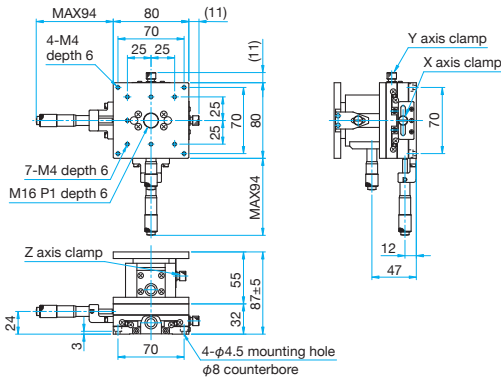

TSD-805S Hexagonal socket head cap screw M4x8...4 screws

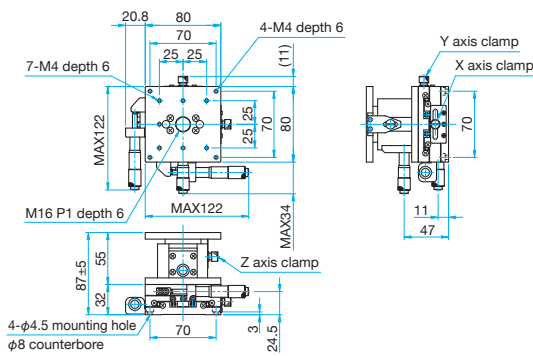

TSD-805SR Hexagonal socket head cap screw M4x8...4 screws

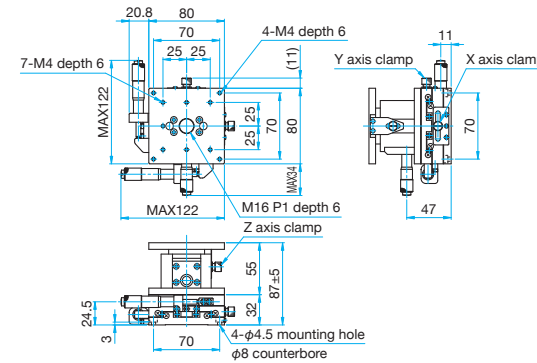

TSD-1005C Hexagonal socket head cap screw M4x8...4 screws

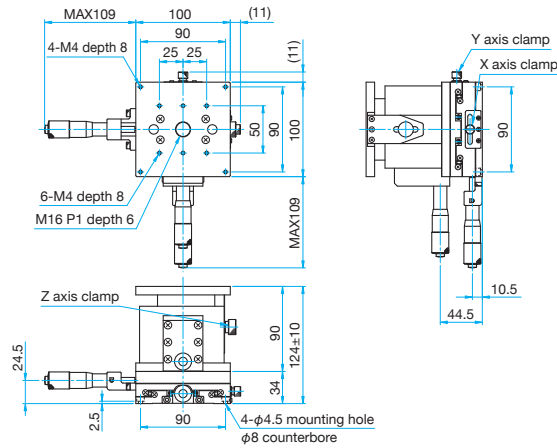

TSD-1005S Hexagonal socket head cap screw M4x8...4 screws

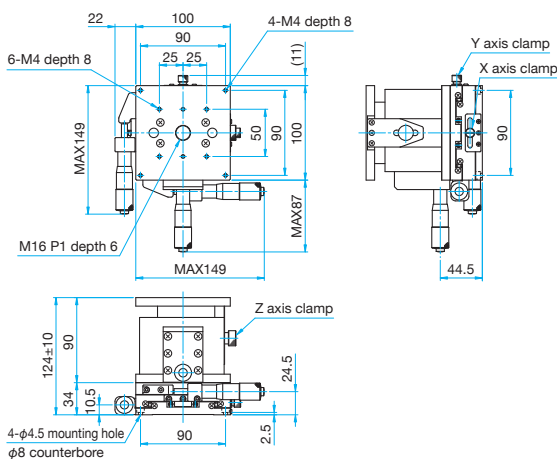

TSD-1005SR Hexagonal socket head cap screw M4x8...4 screws

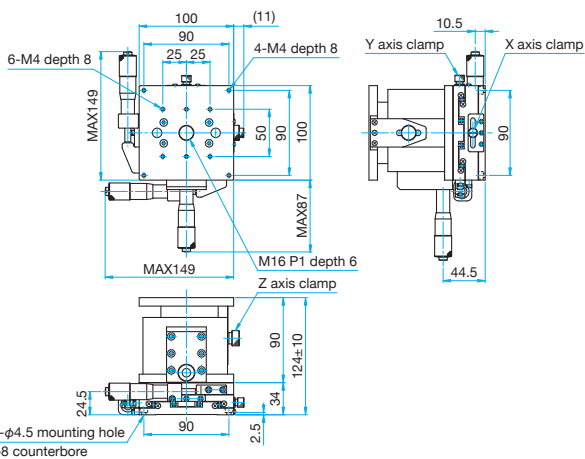

Application Systems

Optics & Optical Coatings

Opto-Mechanics

Bases

Manual Stages

Actuators & Adjusters

MotORIZED Stages

Light Sources & Laser Safety

Index

Guide

X Axis Stages

XY Axis Stages

Z Axis Stages

XZ Axis Stages

XYZ Axis Stages

Rotation Stages

Goniometer

Tilt Stages

Vacuum

Ball Bearing Guide

Crossed Roller

Dovetail

Lapping

V Groove Screw

Ohters

15 × 15 mm

25 × 25 mm

40 × 40 mm

60 × 60 mm

65 × 65 mm

80 × 80 mm

100 × 100 mm

120 × 120 mm

Others