

Stepping motor driven stages, ideal for positioning of measuring instruments or inspection tools for which high stiffness and high precision are required.



- U-shaped rail offers light weight, and minimized deflection to achieve high stiffness.

#### Guide

- ▶ Contact our Sales Division if you desire to change motors, etc.  
[Reference](#) G017, G123 (Motorized Stage System Question Sheet)  
[WEB Reference](#) [Catalog Code](#) W9500
- ▶ Grease change is optionally available.  
[Reference](#) G122 [WEB Reference](#) [Catalog Code](#) W9006
- ▶ We will assemble your X axis stage with a newly purchased X axis stage at a separate cost.

#### Specifications

| Part Number                               |                                     | OSMS33-300(X)  | OSMS33-500(X)                              |      |
|---|-------------------------------------|--|--|------|
| Part Number (-M6)                         |                                     | OSMS33-300(X)-M6                                     | OSMS33-500(X)-M6                           |      |
| Part Number (-INCH)                       |                                     | OSMS33-300(X)-INCH                                   | OSMS33-500(X)-INCH                         |      |
| Mechanical Specifications                 | Travel [mm]                         | 300  | 500  |      |
|   | Stage Size [mm]                     | 120x120  | 120x120                                    |      |
|   | Feed Screw                          | Ball screw diameter $\phi$ 10mm, 10mm lead           | Ball screw diameter $\phi$ 10mm, 10mm lead |      |
|   | Positioning Slide                   | Outer rail structure                                 | Outer rail structure                       |      |
|   | Stage Material                      | Aluminum   | Aluminum                                   |      |
|   | Finish                              | Black anodized                                       | Black anodized                             |      |
|   | Weight [kg]                         | 7.0  | 8.6  |      |
| Accuracy Specifications                   | Resolution                          | (Full) [ $\mu$ m/pulse]                              | 20   | 20   |
|   |                                     | (Half) [ $\mu$ m/pulse]                              | 10   | 10   |
|   | MAX Speed [mm/sec]                  | 120  | 120  |      |
|   | Positioning Accuracy [ $\mu$ m]     | 25   | 25   |      |
|   | Positional Repeatability [ $\mu$ m] | 6  | 6  |      |
|   | Load Capacity [N]                   | 196 (20.0kgf)  | 196 (20.0kgf)                              |      |
|   | Moment Stiffness                    | Pitch [ $^{\circ}$ /N·cm]                            | 0.12                                       | 0.12 |
|   |                                     | Yaw [ $^{\circ}$ /N·cm]                              | 0.08                                       | 0.08 |
|   |                                     | Roll [ $^{\circ}$ /N·cm]                             | 0.1  | 0.1  |
|   | Lost Motion [ $\mu$ m]              | 5  | 5  |      |
|   | Backlash [ $\mu$ m]                 | 3  | 3  |      |
|   | Parallelism [ $\mu$ m]              | 50   | 50   |      |
|   | Running Parallelism [ $\mu$ m]      | 15   | 25   |      |
| Pitch [ $^{\circ}$ ] / Yaw [ $^{\circ}$ ] | 40/25                               | 40/25  |  |      |
| Sensor                                    | Sensor Part Number                  | Micro photo sensor: GP1S092HCPIF (Sharp Corporation) |  |      |
|   | Limit Sensor                        | Equipped (NORMAL CLOSE)                              | Equipped (NORMAL CLOSE)                    |      |
|   | Origin Sensor                       | Equipped (NORMAL OPEN)                               | Equipped (NORMAL OPEN)                     |      |
|   | Proximity Origin Sensor             | Equipped (NORMAL OPEN)                               | Equipped (NORMAL OPEN)                     |      |

#### Motor / Sensor Specifications

|        |                     |   |
|--------|---------------------|---|
| Motor  | Type                | 5-phase stepping motor 0.75A/phase (Tamagawa Seiki Co., Ltd.)   |
|        | Motor Part Number   | TS3667N43E967 ( $\square$ 42mm)   |
|        | Step Angle          | 0.72 $^{\circ}$   |
| Sensor | Power Voltage       | DC5 - 24V $\pm$ 10%   |
|        | Current Consumption | 80mA or lower (20mA or lower per sensor)  |
|        | Control Output      | NPN open collector output DC30V or lower, 50mA or lower   |
|        | Output Logic        | When shaded: Output transistor OFF (no conduction) : Limit Sensor<br>When shaded: Output transistor ON (conduction): Origin sensor, Proximity Origin Sensor |

#### Compatible Driver / Controller

|                |                       |  |
|----------------|-----------------------|--|
| Control System | Compatible Driver     | MC-S0514ZU, SG-514MSC, MC-7514PCL                                |
|                | Compatible Controller | SHOT-702, HSC-103, SHOT-302GS, SHOT-304GS, HIT-M·HIT-S, PGC-04-U |

Application Systems

Optics &amp; Optical Coatings

Opto-Mechanics

Bases

Manual Stages

Actuators &amp; Adjusters

Motorized Stages

Light Sources &amp; Laser Safety

Index

Guide

Controllers/Drivers

Softwares

Stepping Motor

AC Servo Motor

Cables

Piezo

X Translation

Theta Rotation

Goniometer

Vacuum

Options

40 x 40 mm

60 x 60 mm

80 x 80 mm

85 x 85 mm

100 x 100 mm

120 x 120 mm

Others



Outline Drawing

**OSMS33-\*(X)** Hexagon socket head cap screw M6x12...14 screws (300)  
Hexagon socket head cap screw M6x12...22 screws (500)

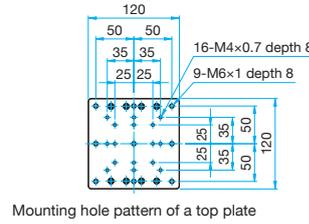
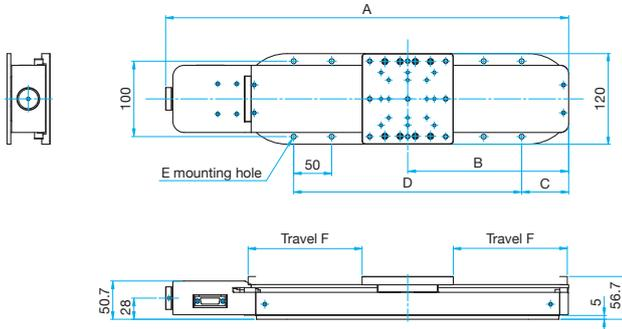

Mounting hole pattern of a top plate

| Part Number   | A     | B     | C    | D           | E       | F   |
|---------------|-------|-------|------|-------------|---------|-----|
| OSMS33-300(X) | 530.3 | 211.8 | 61.8 | 300 (50x6)  | 14-φ6.5 | 150 |
| OSMS33-500(X) | 730.3 | 311.8 | 61.8 | 500 (50x10) | 22-φ6.5 | 250 |

**OSMS33-\*(X)-M6** Hexagon socket head cap screw M6x12...14 screws (300)  
Hexagon socket head cap screw M6x12...22 screws (500)

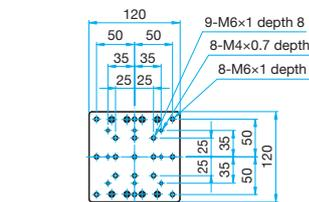
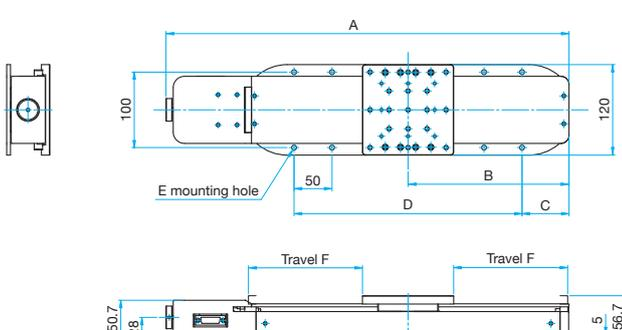

Mounting hole pattern of a top plate

| Part Number      | A     | B     | C    | D           | E       | F   |
|------------------|-------|-------|------|-------------|---------|-----|
| OSMS33-300(X)-M6 | 530.3 | 211.8 | 61.8 | 300 (50x6)  | 14-φ6.5 | 150 |
| OSMS33-500(X)-M6 | 730.3 | 311.8 | 61.8 | 500 (50x10) | 22-φ6.5 | 250 |

**OSMS33-\*(X)-INCH** Hexagon socket head cap screw 1/4-20UNCx1/2...14 screws (300)  
Hexagon socket head cap screw 1/4-20UNCx1/2...22 screws (500)

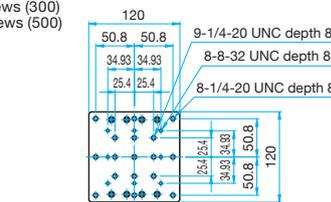
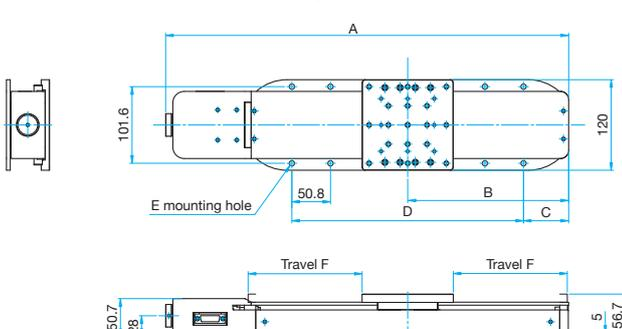

Mounting hole pattern of a top plate

| Part Number        | A     | B     | C    | D              | E     | F   |
|--------------------|-------|-------|------|----------------|-------|-----|
| OSMS33-300(X)-INCH | 530.3 | 211.8 | 59.4 | 304.8 (50.8x6) | 14-φ7 | 150 |
| OSMS33-500(X)-INCH | 730.3 | 311.8 | 57.8 | 508 (50.8x10)  | 22-φ7 | 250 |

Connection Diagram

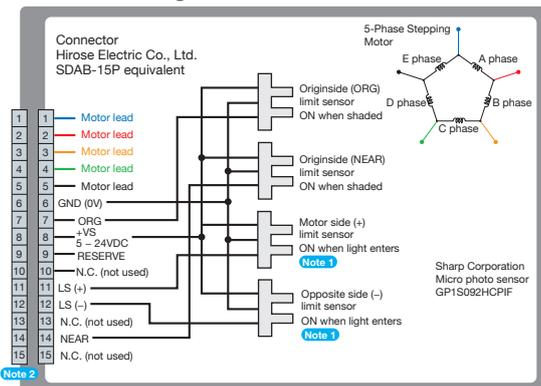

**Note 1** The motor side limit sensor is the + direction limit sensor.  
**Note 2** Compatible cable connector: DDK Ltd. 17JE-13150

Compatible Controllers / Drivers and Cables

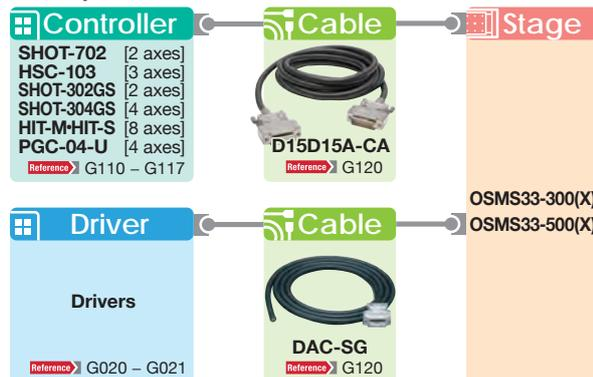

Application Systems

Optics & Optical Coatings

Opto-Mechanics

Bases

Manual Stages

Actuators & Adjusters

MotORIZED Stages

Light Sources & Laser Safety

Index

Guide

Controllers/Drivers

Softwares

Stepping Motor

AC Servo Motor

Cables

Piezo

X Translation

Theta Rotation

Goniometer

Vacuum

Options

40 x 40 mm

60 x 60 mm

80 x 80 mm

85 x 85 mm

100 x 100 mm

120 x 120 mm

Others