

Linear Positioning Stage for Closed- Loop Operation

NON- MAGNETIC AND VACUUM- COMPATIBLE



N-603

- + Travel range 2 mm
- + Extremely low profile with only 7.4 mm for serial mounting
- + With position sensor for closed- loop operation
- + PiezoWalk® drive
- + For operation in strong magnetic fields

Linear actuator for extreme ambient conditions

1 axis. Frictionless flexure- guided design, directly driven. Strain gauge sensor for positioning feedback

NEXACT® piezo stepping drive

Non- magnetic, high- resolution piezoelectric linear drive. Compact design, holding force up to 5 N

Fields of application

Sample handling and positioning, optics alignment or micro handling in magnetic fields or high vacuum

Specifications

Preliminary data	N-603.2SD
Active axes	X
Motion and positioning	
Integrated sensor	SGS
Closed- loop travel	2 mm
Closed- loop resolution	0.5 µm
Linearity, closed- loop	5 µm
Repeatability	1 µm
Velocity	2 mm in 0.25 s
Mechanical properties	
Unloaded resonant frequency	750 Hz
Holding force in motion direction	6 N
Drive properties	
Piezoceramics	NEXACT® piezo stepping drive
Miscellaneous	
Operating temperature range	0 to 50 °C
Material	Titanium, non- magnetic
Dimensions	42 mm × 42 mm × 7.4 mm
Recommended controller / amplifier	E-861.1S1

Order Information

N-603.2SD

PiezoMove OEM Linear Long- Range Actuator with NEXACT® Drive, 2 mm, SGS Sensor

Ask about custom designs!

Controllers / Drivers / Amplifiers

[E-861 PiezoWalk® NEXACT® Controller / Driver](#)

Technology

[PiezoWalk® Piezo Stepping Drives | NEXLINE® stepping drives are designed for high push and holding forces of up to 800 N and work with low velocities. Learn more ...](#)

Drawings / Images

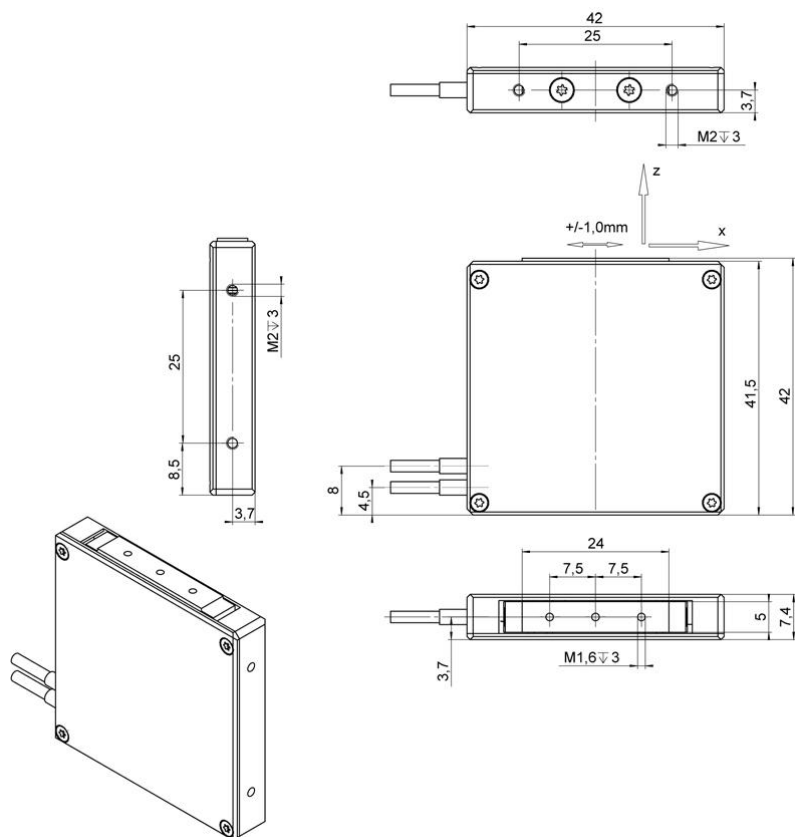

N-603, dimensions in mm