

HS1 NANOPositionER

The HS1 is a compact nanopositioner which can be combined to form 2 or even 3-axis nanopositioning systems. It is offered with 30, 50 or 70 μ m of range of motion and it can also be proposed with an aperture (see page 08).

This nanopositioner is part of our high-speed product line (High power controller available).

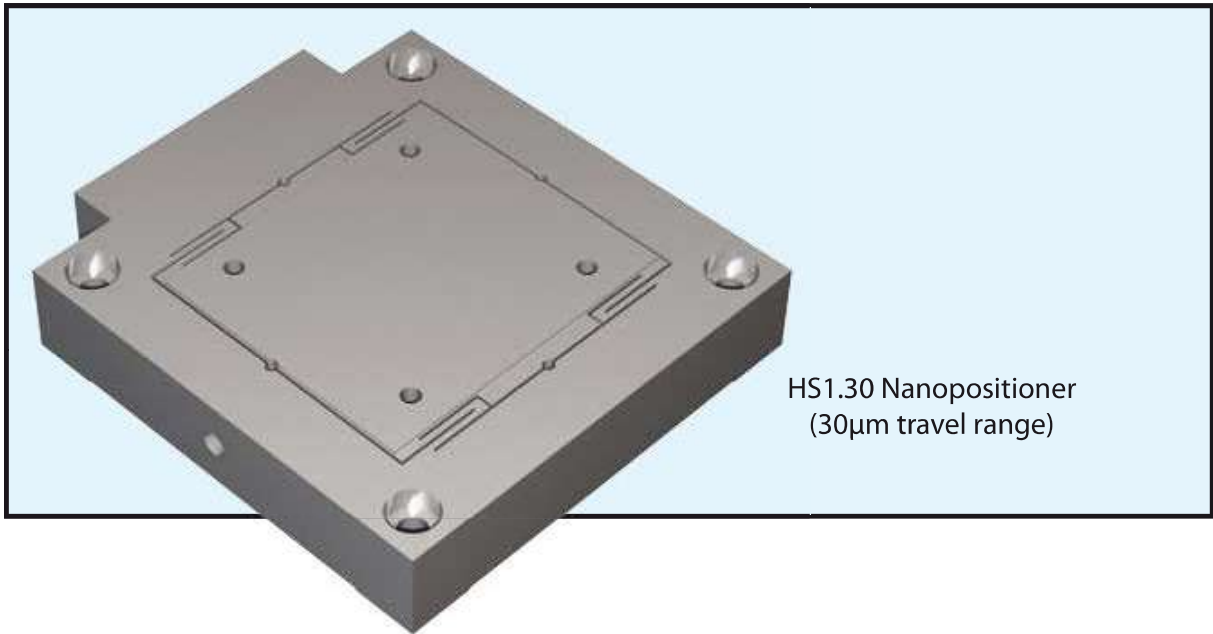

Features

- High speed, direct drive
- Stackable for XY or XYZ motion
- 30, 50 or 70 μ m motion
- Closed loop control
- Silicon sensor technology
- Less than 10pm noise floor

Applications

- Interferometry
- Nanolithography
- 3D polymerisation
- High speed focusing
- Adaptative optics

Specifications

	HS1.30	HS1.50	HS1.70
Range of motion (μm)	30	50	70
Resolution (nm)	0,03	0,05	0,07
Typical noise floor (nm)	0,003	0,005	0,007
Full range repeatability (nm)	0,06	0,1	0,14
Linearization (typical)	0,02%	0,02%	0,02%
Resonant frequency (Hz)	4000	4000	4000
Stiffness ($\text{N}/\mu\text{m}$)	3	3	3
Maximum load (kg) - horizontal use	1	1	1
Maximum load (kg) - vertical use	0,5	0,5	0,5
Sensor	Silicon HR sensor	Silicon HR sensor	Silicon HR sensor
Size W x L x H (mm)	62,5 x 69,50 x 12,6	62,5 x 89,50 x 12,6	62,5 x 111,50 x 12,6
Material	Al	Al	Al
Cable length (m)	2	2	2
Recommended Controller	Standard or High Speed	Standard or High Speed	Standard or High Speed

Drawing

