

OES-Star UV-NIR OES Spectrometer

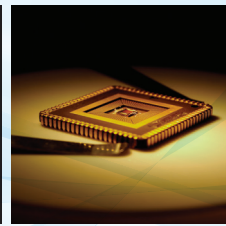
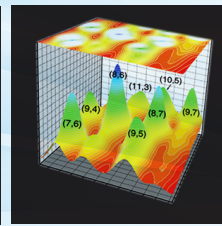
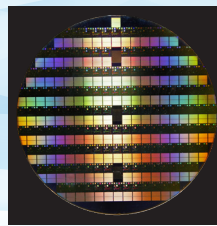

For OEM Semiconductor
Industrial Applications

OES-Star UV-VIS-NIR Spectrometer

Overview

Horiba's OEM division, a major supplier of OES solutions, has developed a high end OES Spectrometer with a proprietary optical configuration for broad coverage (185-1050 nm) and high resolution. The OES-Star is available with a selection of three UV-VIS-NIR Back-Illuminated (B.I.) sensors, one TE-Cooled and two uncooled CCD detectors. This unique OES system features an optical design that provides a high peak symmetry across a very broad spectral range combined with high spectral resolution better than 1 nm, at an unmatched aperture of F/2.3.

Applications

- Optical Emission Spectrometry
- Reflectometry
- Process and Quality Control

Examples:

- Semiconductor
- Plasma Monitoring
- Wafer Inspection

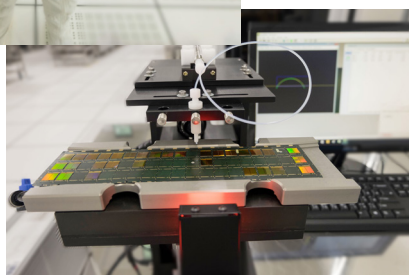
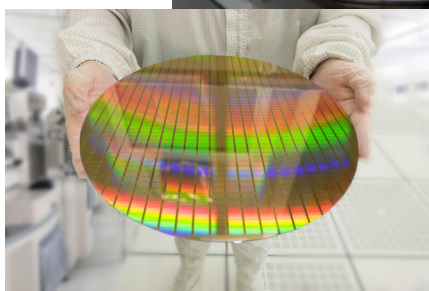
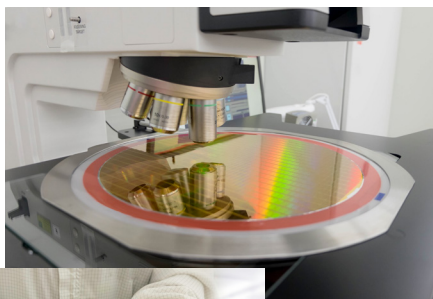

Flat resolution and dispersion across the entire spectral range (185 -1050 nm) combined with excellent peak symmetry

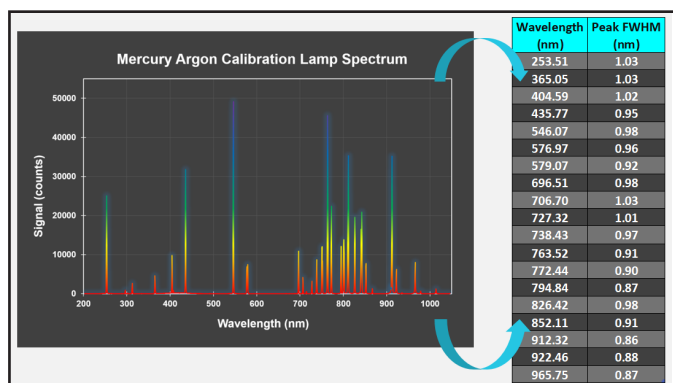

This OES-Star is featuring a tall CCD with built in round-to-line (RTL) fiber converter to maximize light collection and therefore the system throughput. Input fiber with a core of 600 to 800 μm or smaller can be used. However to take advantage of the tall detector and RTL, larger core fibers are recommended.

Features

Optical emission spectrometry (OES)

Unmatched long term stability and excellent wavelength accuracy

USB2
Ethernet and EtherCAT interface

High spectral resolution combined with high throughput

Broad wavelength coverage from UV to NIR

Multiple B.I. CCD options cooled/uncooled with high dynamic range

CMOS sensor option with electronic shutter and ultra high spectral rate

General Spectrometer Specifications*

Spectral Coverage	185 – 1050 nm (2048 horizontal pixel format with 12 or 14 μm pixel size)
Spectrometer Input	SMA (standard), other input types available upon request
Spectral Resolution	<1 nm with 22 μm slit with very high symmetry across broad spectral range (flexible depending of fiber core and slit sizes)
Average Spectral Dispersion	34.6 nm/mm; 0.48 nm/pixel (14 μm pixel size)
Focal Length	116 mm
F/#	F/2.3
Wavelength Accuracy	< 0.1 nm
Stray Light	< 0.1% (typical)
Software	LabVIEW™ acquisition software for initial evaluation (DLLs provided for software integration)

Specifications for OES Back-Illuminated CCD Detector (3 options)

CCD Detector Model	Cooled BI High-end CCD with best dynamic range (S13241-1108S)	BI CCD Middle Grade (S14660-2048N)	BI CCD cost effective (S11071-1106N)
CCD Sensor Format	2048 x 256	2048 x 192	2048 x 70
CCD Pixel Size	12 x 12 μm	14 x 14 μm	14 x 14 μm
Image Size	24.5 x 3.0 mm	28.7 x 2.68 mm	28.7 x 1.0 mm
CCD QE at 20°C	90% at the peak	> 70% for 450 - 750 nm	
Deep Thermoelectric Cooling	-5° C	Non-cooled	Non-cooled
Full Well Capacity	500,000 e ⁻ /pixel (typical)	240,000 e ⁻ /pixel (typical)	
Readout Noise	50 e ⁻ (typical) (@ 1.5MHz sampling)	40 e ⁻ (typical) 50 e ⁻ (maximum)	35 e ⁻ (typical) 45 e ⁻ (maximum)
Digitization	16-bit ADC	16-bit ADC	16-bit ADC
Dynamic range (FW/RN)	10,000:1	6,000:1	6,850:1
Non-linearity (measured on each system)	<1.8% (maximum) at low gain <0.9% (maximum) at high gain	<0.1% (corrected)	<0.1% (corrected)
Dark Current	1.5 e ⁻ /pixel/s (typical) (@-5° C)	50 e ⁻ /pixel/s (typical) @ 20° C 500 e ⁻ /pixel/s (maximum)	
Communication	USB 2, Ethernet and EtherCAT		
Environmental Conditions	Operating temperature +15° C to 40° C ambient; Relative humidity <70% (non-condensing); Storage temperature -20° C to 50° C		
Power Requirements AC/DC Power Supply (provided)	90-264 VAC, 47-63 Hz		

Quantum Efficiency Plot

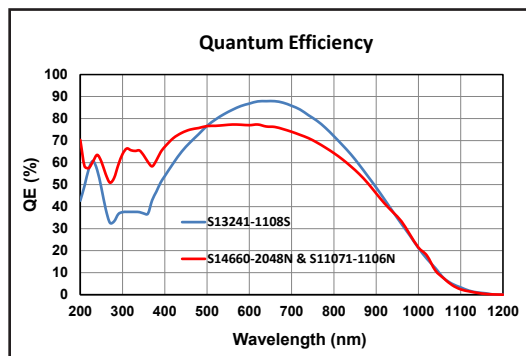

Built-in round-to-line (RTL) converter boosts throughput when combined with a large core diameter fiber and our tall CCD (S13241-1108S)

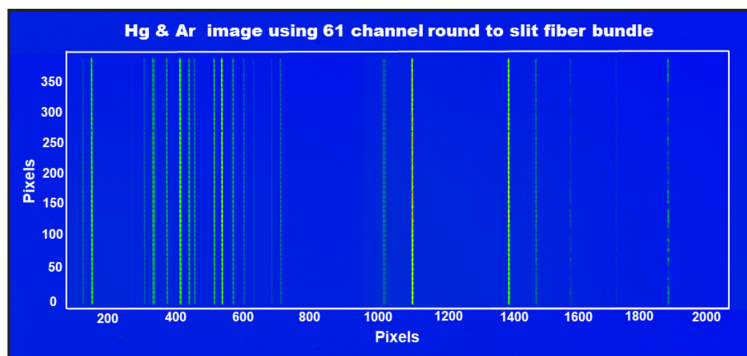

*Specifications, form factor, and spectrometer cover subject to change without notice. No LabVIEW™ license is needed to run our acquisition software.

System Mechanical Drawings

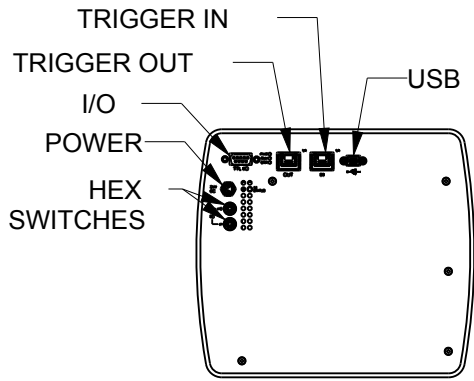
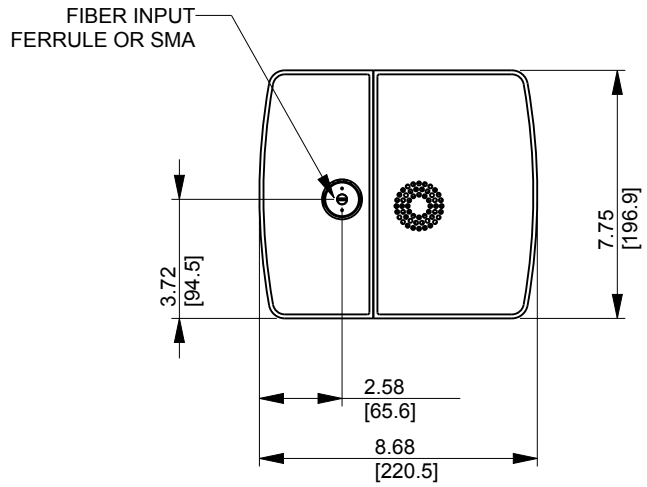
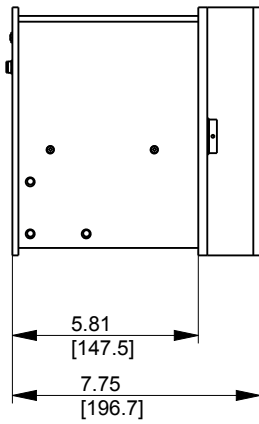
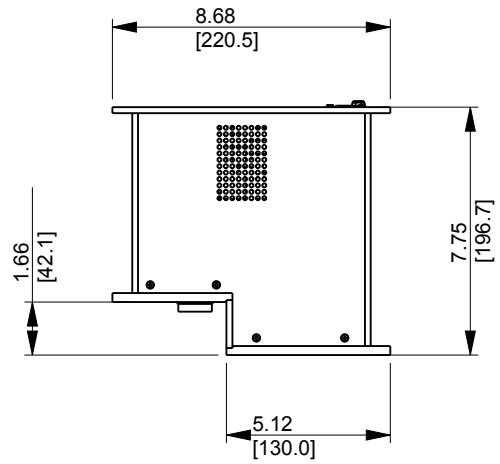
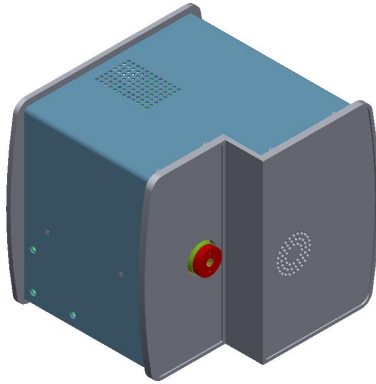

REAR VIEW

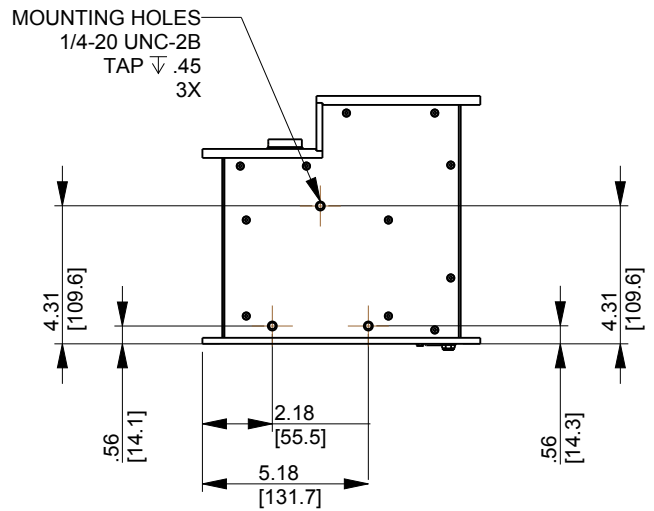

UNITS IN INCHES [MILLIMETERS]

Best Selling Miniature Spectrometers for OEM Industrial Applications

Fiber-coupled USB Spectrometers:

MiniVS20 Spectrometer with Linear UV-VIS CMOS or NIR INGAAS sensor

5 nm resolution

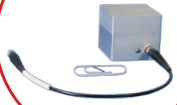

OEM hand-held spectrometer covering 190 to 1,700 nm for various low stray light applications

- Aberration-corrected concave holographic grating options
- VIS configuration featuring a 1.7" x 1.9" x 2" size combined with full F/2.3 optics for high signal-to-noise
- High throughput, compactness and long term reliability

MiniVS70 VIS Spectrometer with FI CMOS or BI CCD

1 nm resolution

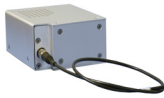

NEW miniaturized VS70 configuration

- Based on high performance aberration-corrected concave gratings fitted with a custom order-sorting filter to eliminate higher orders
- Low cost combined with high performance and low stray light
- Long term opto-mechanical stability and choice of front-illuminated linear CMOS or back-illuminated CCD sensors

VS70 UV-VIS-NIR Spectrometer with uncooled / TE-cooled CCD

1-2 nm resolution



Most popular, compact versatile VS70 OEM Spectrometer and OES configurations

- Based on high performance aberration-corrected concave gratings with full F/2.3 aperture
- SINGLE or DUAL fiber channel versions available
- Affordable high throughput, robust and stable
- Electronics drivers ranging from **USB 2 to Ethernet and EtherCAT**

CiCi-Raman-NIR with scientific camera optimized for 785 nm

6 cm⁻¹ resolution

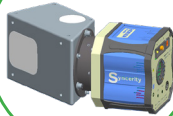

Most compact OEM Raman spectrometer with aberration-corrected holographic grating

- Covers 150-3,300 cm⁻¹
- High efficiency and low stray light
- Available in F/2.3 and in compact F/5 configurations
- -50° C deep-cooled scientific CCD camera with minimized etaloning and high NIR QE

PoliSpectra® Quad Spectrometer for simultaneous acquisition of 4 VIS spectra

1 nm resolution



CCD spectrometer for simultaneous acquisition from 4 fiber inputs (470-730 nm)

- High-speed electronics (as fast as <1.5 msec readout time for 4 spectra)
- QUAD-channel high throughput system (f/2.3) and ultra-low stray light
- Industrial low light applications from low light fluorescence to reflectance

PoliSpectra® M116 8-32 channel MultiTrack UV-VIS-NIR CMOS spectrometer

1 nm resolution



Fiber-coupled multi-spectra system with 8 to 32 channel simultaneous measurements

- Concentric optical design with UV extended spectral range provides minimized crosstalk
- High throughput USB 3 system featuring a fast 2D scientific BI CMOS running at 94 to 188 frames per second, acquiring 8, 16 or 32 simultaneous spectra (2048 pixels per spectrum)

PoliSpectra® H116 Imaging Spectrometer for hyperspectral work from UV to NIR

Free-space coupled
1 nm & 40 μm resolution



Ultra-high performance rugged spectrometer for hyperspectral imaging with a 2D sCMOS Camera

- For line-image scanning, in a push-broom hyperspectral configuration
- High throughput, USB 3 system featuring a fast 2D scientific BI CMOS with rolling shutter, running at 94 (HDR) to 188 (Standard Mode) frames per second (2048 pixels per spectrum)

OEM Spectrometer Selection Guide

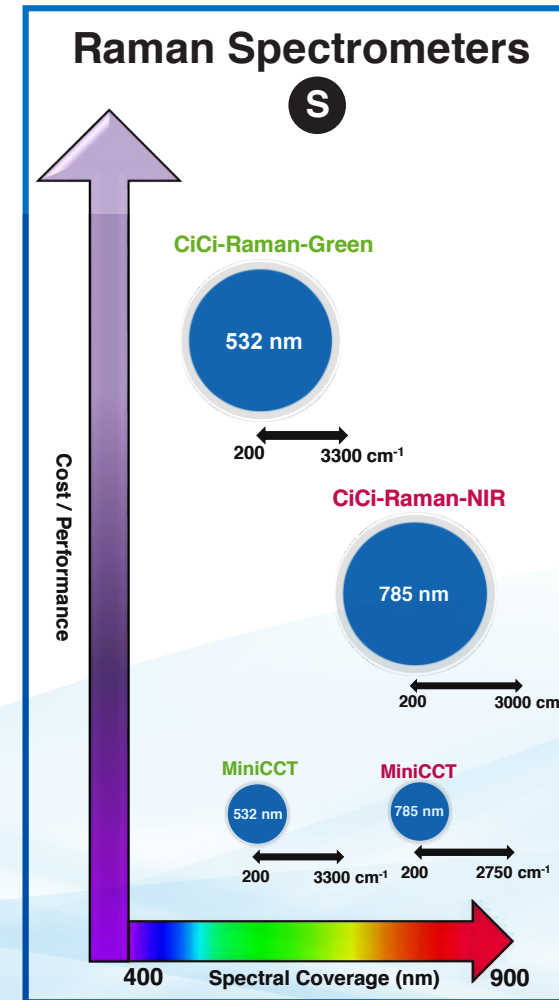
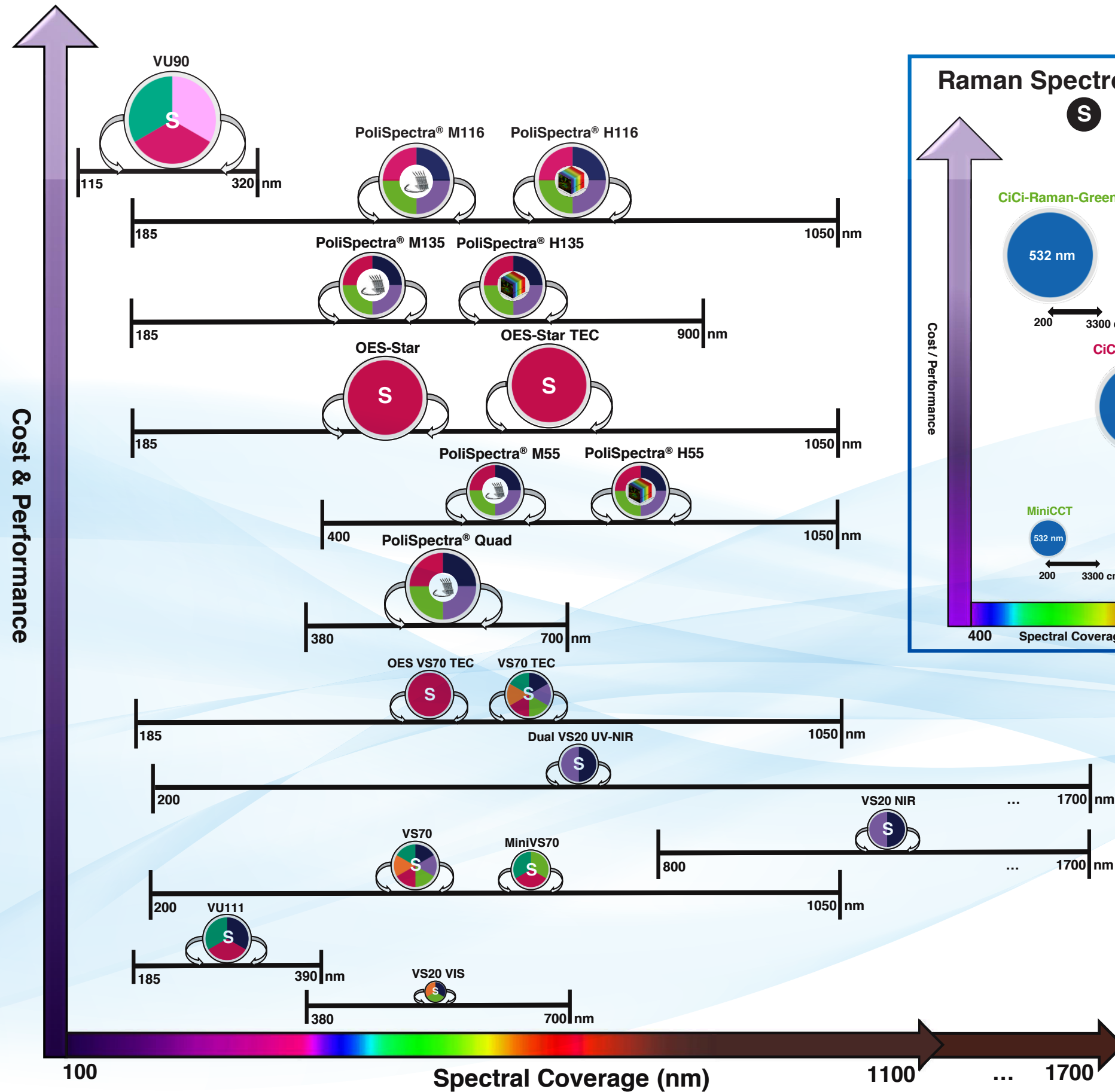

Legend

Spectrometer Input Type

- S** Single-fiber Input
- Multi-fiber Input
- Hyperspectral Imager

Technique & Application

- Emission (OES)
- Absorbance
- Fluorescence
- Reflectance
- Raman
- Metrology
- Photoluminescence
- Colorimetry

Spectrometer Size

- ≤ 10.5x9x7 inches
- ≤ 8x8x8 inches
- ≤ 7.5x4.5x5 inches
- ≤ 7.5x4.5x3 inches
- ≤ 6x6x7.5 inches
- ≤ 5x5x5 inches
- ≤ 5x5x2 inches
- ≤ 2x2x2 inches

OEM Philosophy and Mission

3 Centers of Excellence Dedicated to OEM Spectroscopy and Camera Solutions in US, EU, and Asia

Our mission is to provide a complete development and manufacturing experience, from optical simulations to opto-mechanical design and prototyping of spectroscopic and camera systems extending to, and including, electronics, firmware, software design and first articles.

Our products provide superior performance, reliability and stability, combined with robust cost reduction. Capable of flexible high volume production capacity in quantities of hundreds to thousands per year, we offer full confidentiality providing "Black Boxes" or private labelling, using your logo or graphics.

Unmatched customer service is provided by our exceptionally experienced workforce featuring on-time delivery and flexibility, allowing scheduling modifications.

Adhering to Copy Exactly! (CE!) processes, our fully trained staff from engineering to manufacturing form a dedicated OEM engineering force that supports you over the lifetime of the product.

Scientific Segment - OEM Products and Capabilities:

- Custom master optical diffraction gratings
- Diffraction grating replicas (concave, convex and flat)
- Spectrometers, optical assemblies with pre-aligned sensors (CCD, PDA, CMOS, InGaAs) using either customers' or HORIBA's OEM electronics
- OES spectrometers
- Spectroscopy systems or modular engines, such as mini fluorometers and mini Raman systems
- Single and double scanning monochromators
- Imaging spectrographs and spectrometers with CCD or CMOS cameras
- Multispectra spectrometers with multiple fiber inputs / MultiTrack spectroscopy
- Hyperspectral system with HORIBA or customer provided camera (Push-broom configurations)
- Cameras: Spectroscopic deep-cooled scientific cameras (1D and 2D CCD & InGaAs – FI and BI)
- OEM electronics for optosensors ranging from PD and PDA to CCD and CMOS sensors
- Imaging cameras: Uncooled and cooled with FI and BI high-end scientific CMOS
- VUV/FUV spectrometers and CCD vacuum and N2-purged cameras

Scientific Deep Cooled CCD, InGaAs and CMOS Cameras

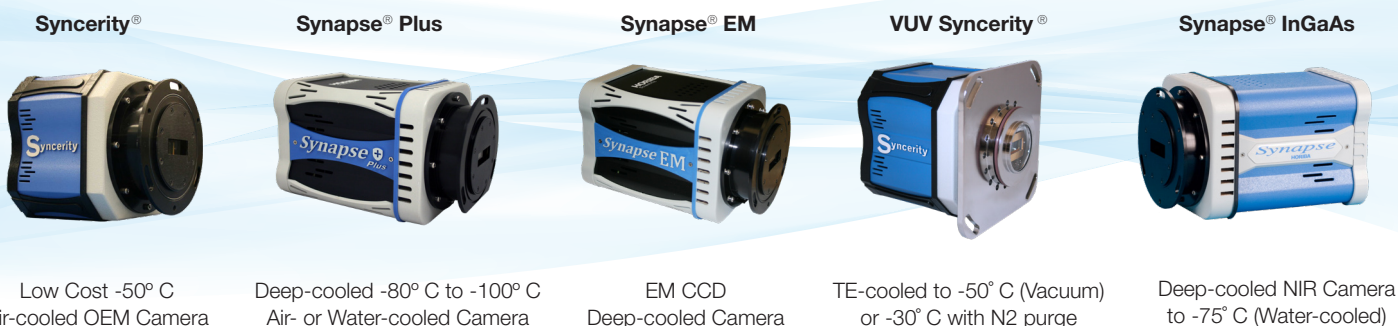

	USA & Canada OEM.US@horiba.com +1 732 494 8660 Ext. 7733	Japan OEM.JAPAN@horiba.com +81 (75) 313 8121	Europe & Asia OEMSALES.JYFR@horiba.com +33 (0) 1 69 74 72 00
---	--	---	---