

H1034 Imaging Scanning Monochromator

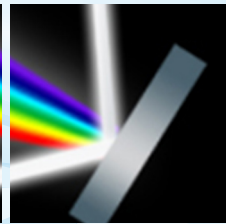
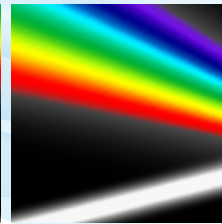
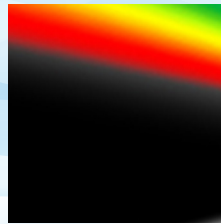
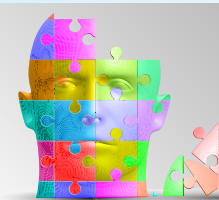
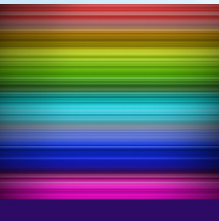

For OEM
Industrial Applications

H1034 Imaging Scanning Monochromator

Overview

HORIBA Scientific OEM has developed a high-throughput imaging scanning monochromator based on an aberration-corrected concave holographic grating with low stray light and high efficiency. This proprietary layout with single optics design is ideal for imaging for low-light applications. It features a 3-position external filter wheel, TTL drive electronics, 4-phase stepper motor and associated worm/gear 90:1 ratio mechanism, encoded, aligned and focused at factory.

This instrument can be used as both a tunable excitation light source and a fluorescence emission scanning monochromator, thanks to high grating efficiency in both first and second orders of diffraction. It is also equipped with two opto-sensors and associated hardware for home calibration.

Applications

Absorbance, Fluorescence and Emission such as:

- Life Sciences (Plate Readers)
- Chemical Analysis
- High-performance Liquid Chromatography (HPLC)
- End-point Determination
- Color Measurement
- Environmental, Agricultural and Food

Optical and Mechanical Layout

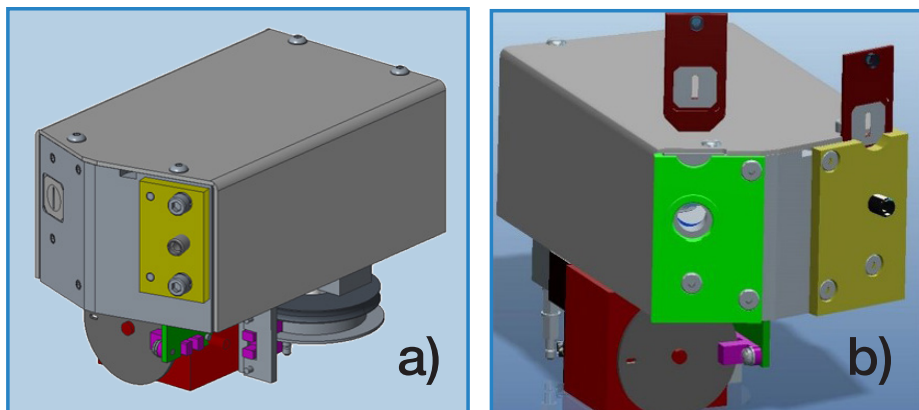

H1034 scanning monochromator with

- a) Input fixed slit and output SMA fiber adapter (standard); and
b) Input and output interchangeable slits (upgrade)

Features

**Scanning monochromator
with superb imaging**

**Covering UV to
NIR range**

**High throughput
and
low stray light**

**Fast, reliable
and reproducible**

**4-phase stepper motor
and associated worm/gear
90:1 ratio mechanism**

**3-position external
filter wheel and
TTL drive electronics**

Many grating choices

General Monochromator Specifications*

Spectral Coverage	185 – 1100 nm (Effective coverage depending on grating blaze selection)
Spectrometer Input	Free space; SMA; Customization on request
Spectral Resolution	<1 nm with 100 μm x 8 mm slit
Focal Length	100 mm
Optical Dispersion	7.8 nm/mm
Stray Light	<0.1% (typical)
Wavelength Accuracy	± 1 nm with linear fitting
Step Repeatability	± 0.1 nm (with 1200 g/mm grating)
F#	F/2.8
Option:	OEM drive electronics with custom console app

* HORIBA Instruments has a policy of continuous product development, and reserves the right to amend part numbers, descriptions and specifications without prior notice.

Grating Selection

H1034 monochromator can be built with several grating choices that all have the same parameters such as curvature, groove density, correction of the aberrations, angle of deviation, and more. What differs among them is the blazed wavelength.

Grating Type	Blaze Wavelength			
Aberration-corrected Concave Holographic Grating	250 nm (covering 185-1000 nm)	350 nm (covering 185-1000 nm)	500 nm (covering 300-1000 nm)	570 nm (covering 350-1000 nm)

Groove Density	1,200 (gr/mm)
F/#	F/2.8
Dimension	38 mm x 38 mm and 42.4 x 42.4 (± 0.1) mm
Input/Output Angle of Deviation	34.7°
Input Arm Length	105.19 mm
Exit Arm Length	100.46 mm
Coating	Aluminum
Grating Efficiency	See the plots below

Grating Efficiency Curves

H1034 gratings can be used in first order for emission scanning and in second and first orders for excitation scanning.

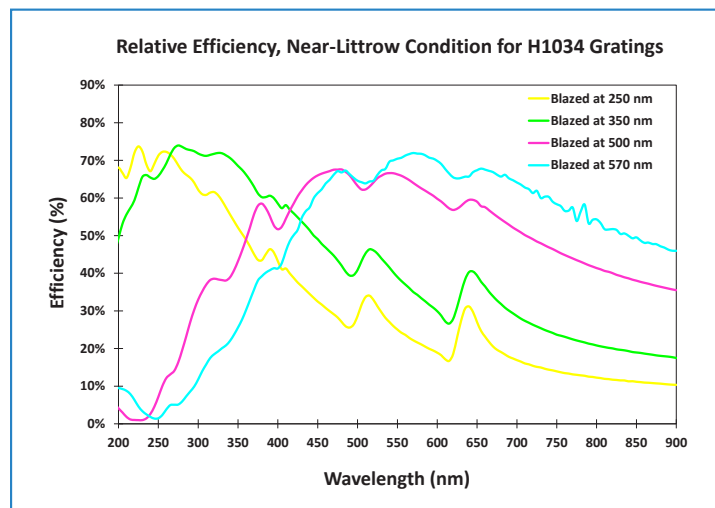

Additional H1034 Monochromator Specifications

1- Motor Drive

H1034 monochromator features a 4-phase stepper motor and associated worm/gear 90:1 ratio mechanism, encoded, aligned and focused. Two opto-sensors and associated hardware for home calibration are included in this OEM configuration.

Monochromator stepper motor scanning configuration

Microstepping	8 μ steps per step
Initial velocity or Minimum speed	300 steps / sec
Maximum speed	800 steps / sec
Ramp-up acceleration	8,000 steps / sec ²
Ramp-down acceleration	8,000 steps / sec ²
Threshold speed	1,400 steps/sec

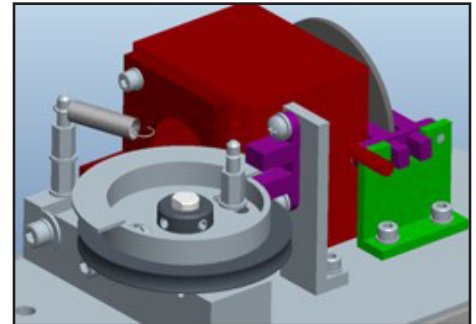

2- Filter Wheel (Optional)

Three-position compact filter wheel with NEMA 8 stepper motor and opto-sensor for homing that can be completely customized to customer's requirements (number of filters, filter sizes, positions, etc).

Filter wheel stepper motor scanning configuration

Microstepping	8 μ steps per step
Initial velocity or minimum speed	0 steps / sec
Maximum speed	500 steps / sec
Ramp-up acceleration	20,008 steps / sec ²
Ramp-down acceleration	2,008 steps / sec ²
Threshold speed	595 steps / sec

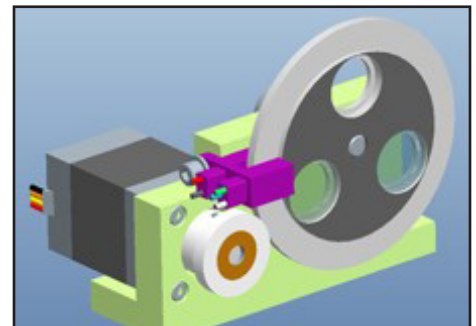

3- Interchangeable Input and Output Slits (Optional)

H1034 monochromator is upgradable to have interchangeable input and output slits with various selections of slit width from 0.012 mm to 4.25 mm and 8 mm height.

4- Drive Electronics for Monochromator and Filter Wheel

H1034 drive electronics with custom software is designed to control the monochromator components and its accessories.

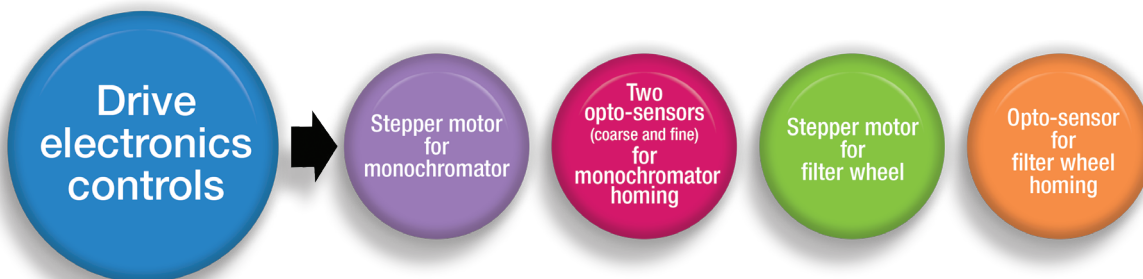

Drive Electronics for H1034 monochromator system.
OEM Industrial grade.

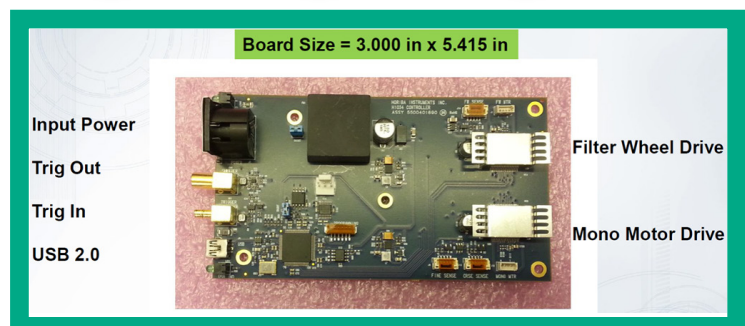

H1034 OEM Designed Electronics Provides:

- **Homing of the monochromator**
- **Two modes of monochromator operations:**
 - 1- Single Wavelength:** Moves to the indicated wavelength; with independent control of the filter wheel (open, closed, LP)
 - 2-Full-Scan:** Scans from starting wavelength to ending wavelength in X nm increments, as fast as possible, with a Y ms repeat cycle. Capable of auto-switching the filter wheel to the required position at a specific wavelength mark
- **Log file output** for the travel time of the grating at each increment to validate switching speed
- **TTL hardware interface** (“TTL In” and “Signal Out”) for best synchronization and hardware communication between monochromator & host system

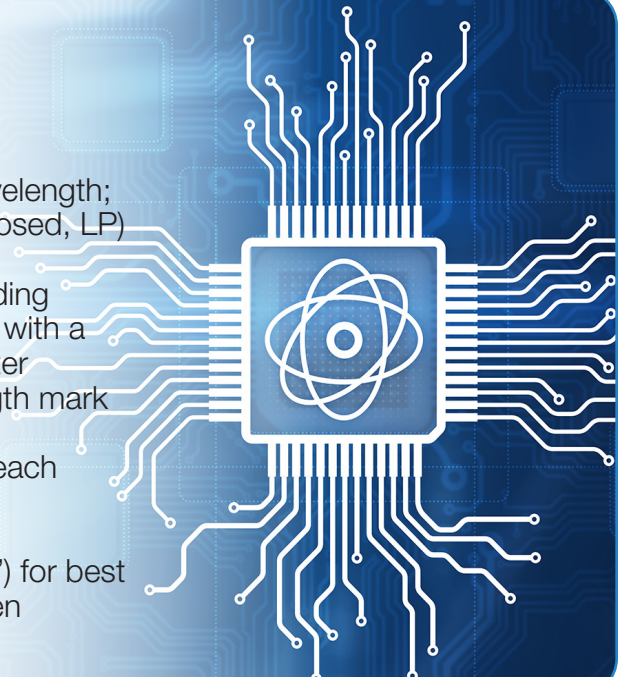

5- Console Application Software & DLL Features

OEM drive electronics has custom software for the H1034 monochromator and the optional shutter/order-sorting mechanism. It is delivered with a console app demo software for fast prototyping, debugging and testing with a super-user configuration tool for customization of the operating parameters, a DLL driver and associated documentation for custom programming (e.g., C#) and integration within the customer's top-level software.

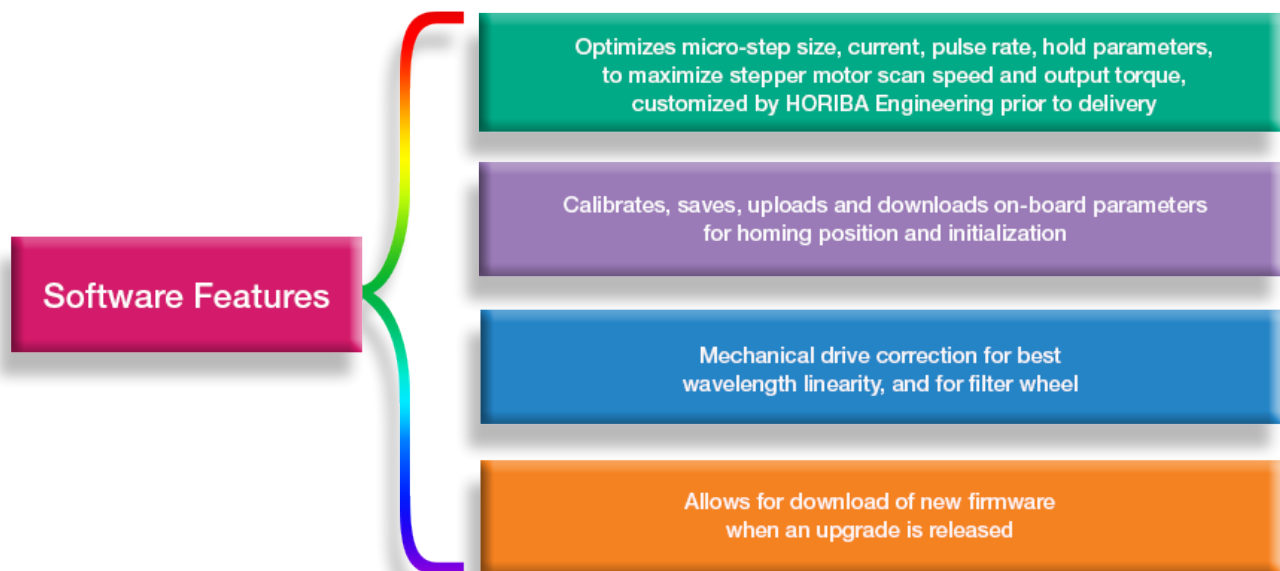

System Mechanical Drawings

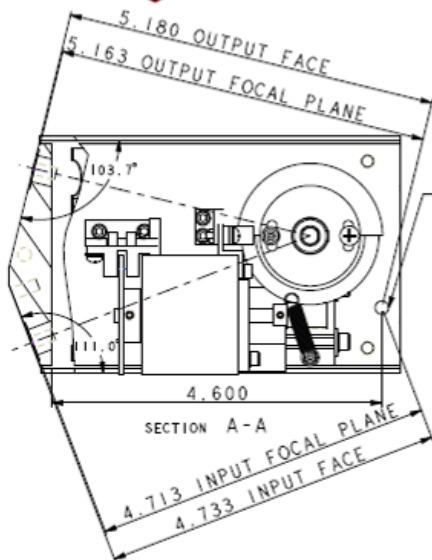
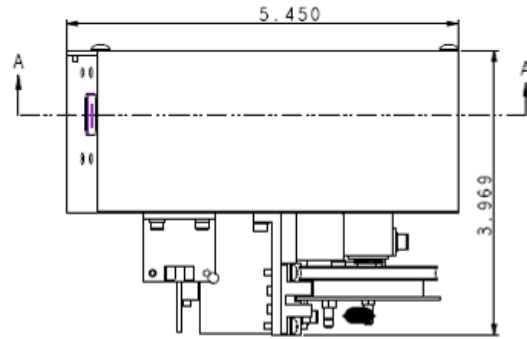
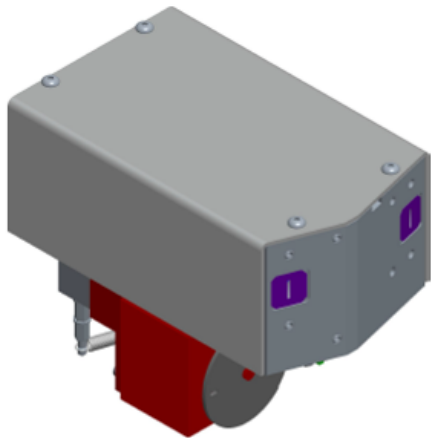

MOUNTING PINS DETAIL

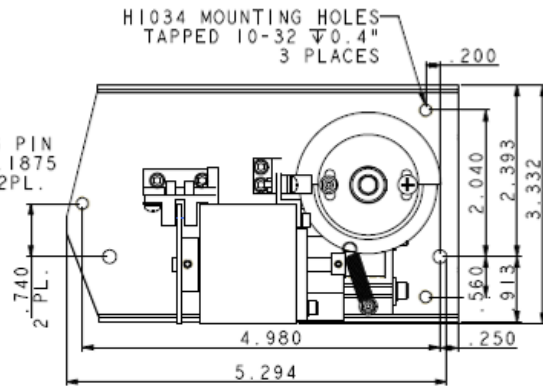

MOUNTING HOLE DETAIL

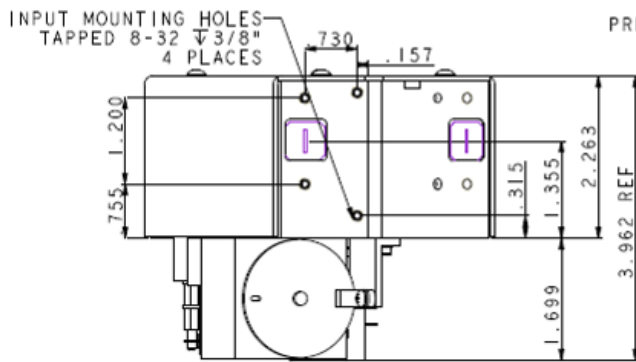

INPUT FACE DETAIL

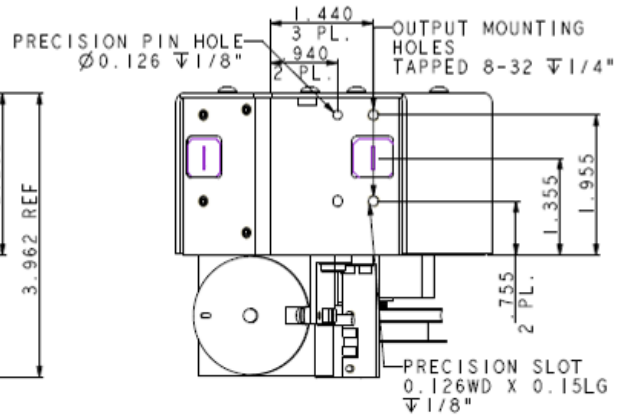

OUTPUT FACE DETAIL

All units are in inches

Best Selling Miniature Spectrometers for OEM Industrial Applications

Fiber-coupled USB Spectrometers:

MiniVS20 Spectrometer with Linear UV-VIS CMOS or NIR INGAAS Sensor

5 nm resolution



OEM hand-held spectrometer covering 190 to 1,700 nm for various low stray light applications

- Aberration-corrected concave holographic grating options
- VIS configuration featuring a 1.7" x 1.9" x 2" size combined with full F/2.3 optics for high signal-to-noise
- High throughput, compactness and long term reliability

MiniVS70 VIS Spectrometer with FI CMOS or BI CCD

1 nm resolution



NEW miniaturized VS70 configuration

- Based on high performance aberration-corrected concave gratings fitted with a custom order-sorting filter to eliminate higher orders
- Low cost combined with high performance and low stray light
- Long term opto-mechanical stability and choice of front-illuminated linear CMOS or back-illuminated CCD sensors

VS70 UV-VIS-NIR Spectrometer with Uncooled / TE-cooled CCD

1-2 nm resolution



Most popular, compact versatile VS70 OEM Spectrometer and OES configurations

- Based on high performance aberration-corrected concave gratings with full F/2.3 aperture
- SINGLE or DUAL fiber channel versions available
- Affordable high throughput, robust and stable
- Electronics drivers ranging from **USB 2 to Ethernet and EtherCAT**

CiCi-Raman-NIR with Scientific Camera Optimized for 785 nm

6 cm⁻¹ resolution

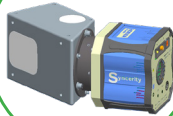

Most compact OEM Raman spectrometer with aberration-corrected holographic grating

- Covers 150-3,300 cm⁻¹
- High efficiency and low stray light
- Available in F/2.3 and in compact F/5 configurations
- -50° C deep-cooled scientific CCD camera with minimized etaloning and high NIR QE

PoliSpectra® Quad Spectrometer for Simultaneous Acquisition of 4 VIS Spectra

1 nm resolution



CCD spectrometer for simultaneous acquisition from 4 fiber inputs (470-730 nm)

- High-speed electronics (as fast as <1.5 msec readout time for 4 spectra)
- QUAD-channel high throughput system (f/2.3) and ultra-low stray light
- Industrial low light applications from low light fluorescence to reflectance

PoliSpectra® M116 8-32 Channel MultiTrack UV-VIS-NIR CMOS Spectrometer

1 nm resolution



Fiber-coupled multi-spectra system with 8 to 32 channel simultaneous measurements

- Concentric optical design with UV extended spectral range provides minimized crosstalk
- High throughput USB 3 system featuring a fast 2D scientific BI CMOS running at 94 to 188 frames per second, acquiring 8, 16 or 32 simultaneous spectra (2048 pixels per spectrum)

PoliSpectra® H116 Imaging Spectrometer for Hyperspectral Work from UV to NIR

Free-space coupled
1 nm & 40 μm resolution



Ultra-high performance rugged spectrometer for hyperspectral imaging with a 2D sCMOS Camera

- For line-image scanning, in a push-broom hyperspectral configuration
- High throughput, USB 3 system featuring a fast 2D scientific BI CMOS with rolling shutter, running at 94 (HDR) to 188 (Standard Mode) frames per second (2048 pixels per spectrum)

OEM Spectrometer Selection Guide

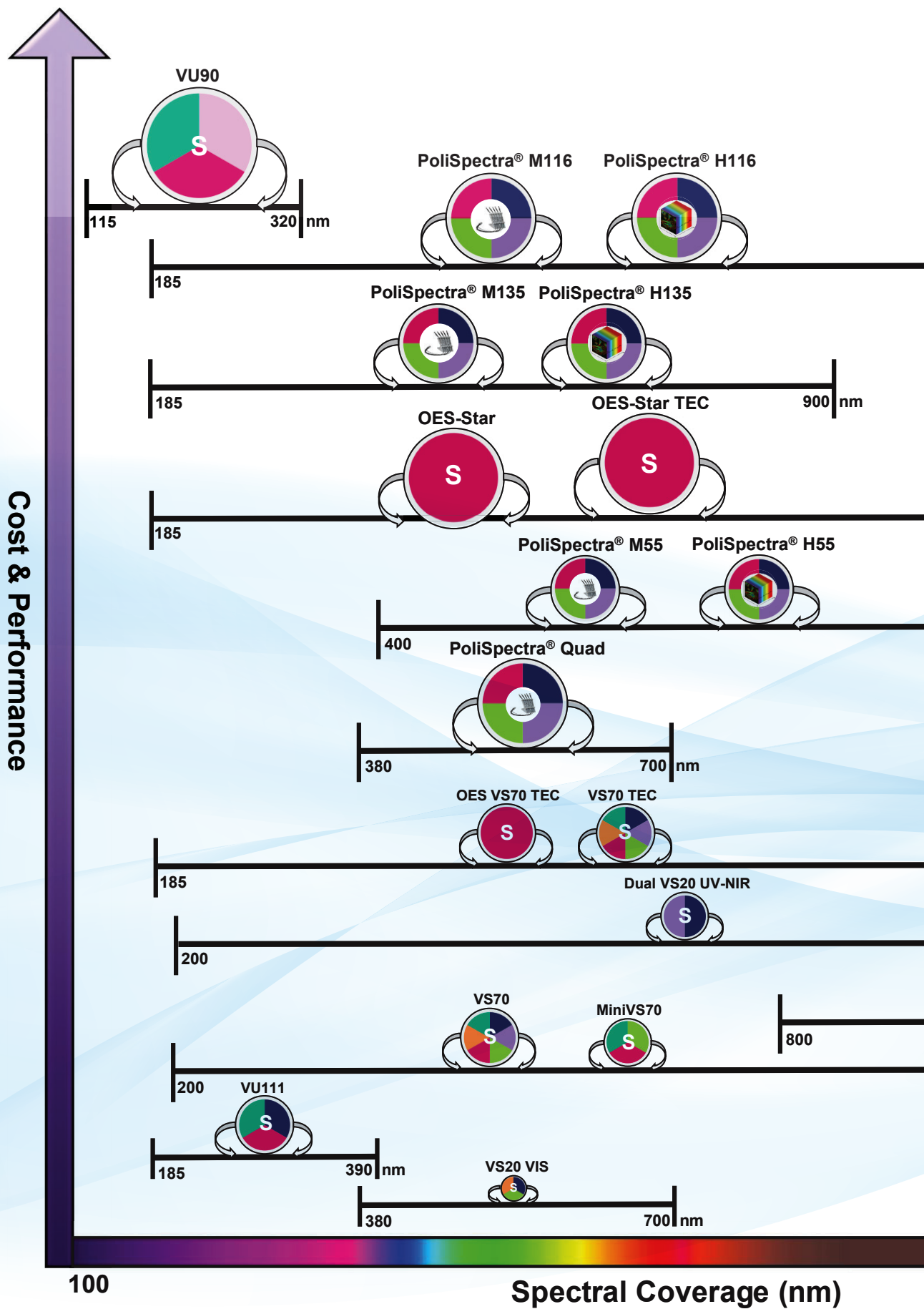

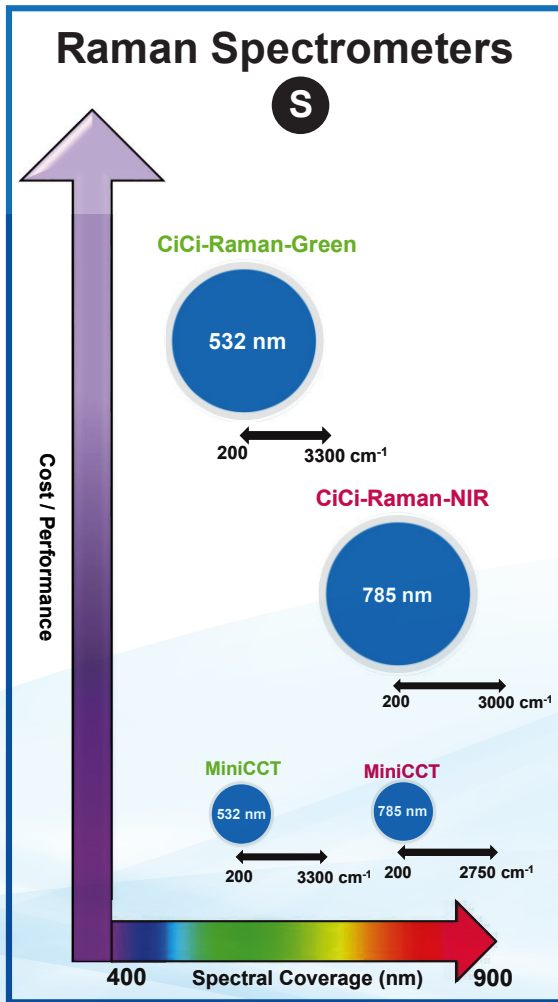

1050 nm

1050 nm

1050 nm

1050 nm

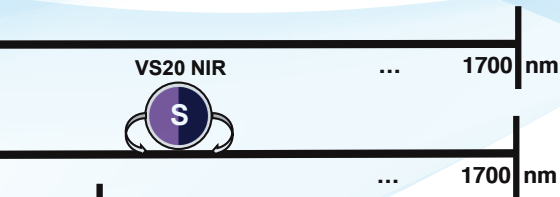

Legend

Spectrometer Input Type

S Single-fiber Input

Multi-fiber Input

Hyperspectral Imager

Technique & Application

- Emission (OES)
- Absorbance
- Fluorescence
- Reflectance
- Raman
- Metrology
- Photoluminescence
- Colorimetry

Spectrometer Size

- $\leq 10.5 \times 9 \times 7$ inches
- $\leq 8 \times 8 \times 8$ inches
- $\leq 7.5 \times 4.5 \times 5$ inches
- $\leq 7.5 \times 4.5 \times 3$ inches
- $\leq 6 \times 6 \times 7.5$ inches
- $\leq 5 \times 5 \times 5$ inches
- $\leq 5 \times 5 \times 2$ inches
- $\leq 2 \times 2 \times 2$ inches

OEM Philosophy and Mission

3 Centers of Excellence Dedicated to OEM Spectroscopy and Camera Solutions in US, EU, and Asia

Our mission is to provide a complete development and manufacturing experience, from optical simulations to opto-mechanical design and prototyping of spectroscopic and camera systems extending to, and including, electronics, firmware, software design and first articles.

Our products provide superior performance, reliability and stability, combined with robust cost reduction. Capable of flexible high volume production capacity in quantities of hundreds to thousands per year, we offer full confidentiality providing "Black Boxes" or private labelling, using your logo or graphics.

Unmatched customer service is provided by our exceptionally experienced workforce featuring on-time delivery and flexibility, allowing scheduling modifications.

Adhering to Copy Exactly! (CE!) processes, our fully trained staff from engineering to manufacturing form a dedicated OEM engineering force that supports you over the lifetime of the product.

Scientific Segment - OEM Products and Capabilities:

- Custom master optical diffraction gratings
- Diffraction grating replicas (concave, convex and flat)
- Spectrometers, optical assemblies with pre-aligned sensors (CCD, PDA, CMOS, InGaAs) using either customers' or HORIBA's OEM electronics
- OES spectrometers
- Spectroscopy systems or modular engines, such as mini fluorometers and mini Raman systems
- Single and double scanning monochromators
- Imaging spectrographs and spectrometers with CCD or CMOS cameras
- Multispectra spectrometers with multiple fiber inputs / MultiTrack spectroscopy
- Hyperspectral system with HORIBA or customer provided camera (Push-broom configurations)
- Cameras: Spectroscopic deep-cooled scientific cameras (1D and 2D CCD & InGaAs – FI and BI)
- OEM electronics for opto sensors ranging from PD and PDA to CCD and CMOS sensors
- Imaging cameras: Uncooled and cooled with FI and BI high-end scientific CMOS
- VUV/FUV spectrometers and CCD vacuum and N2-purged cameras

Scientific Deep Cooled CCD, InGaAs and CMOS Cameras

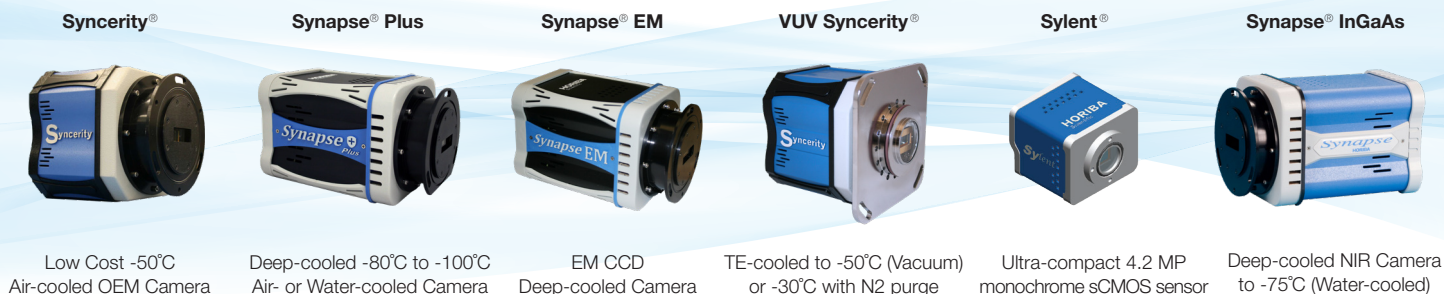

	USA & Canada	Japan	Europe & Asia
	OEM.US@horiba.com	OEM.JAPAN@horiba.com	OEMSALES.JYFR@horiba.com
	+1 732 494 8660 Ext. 7733	+81 (75) 313 8121	+33 (0) 1 69 74 72 00