



## HORNET SPECTROMETER

Compact, Low Cost, 10-40pm Resolution in the UV, Visible and NIR

The Hornet series of spectrometers are based on LightMachinery's high finesse etalons. They are designed primarily for measuring CW or pulsed laser spectra in real time, for characterizing passive components, and for spectroscopy. The Hornet spectrometer from LightMachinery is an ultra compact, low cost spectrometer capable of achieving the resolution of large grating spectrometers at a fraction of their cost and size while covering a large wavelength range. Simple PC based software allows the user to review spectra in real time and save or export for more analysis. LabView drivers enable the Hornet spectrometer to be integrated into automated experimental setups.

### How does it work?

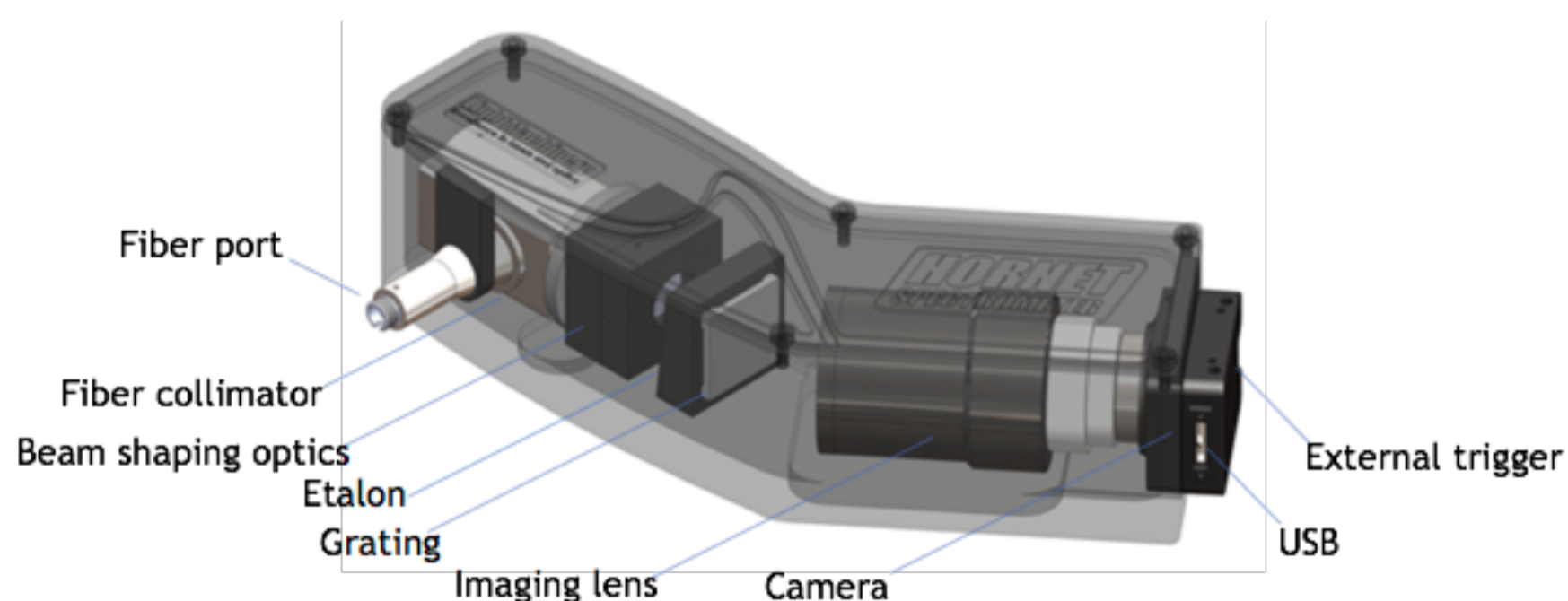

Light enters the Hornet Spectrometer through a fiber. An etalon, manufactured using LightMachinery's proprietary fluid jet polishing technology, is used to produce very high dispersion in the vertical axis with sub-30 picometer resolution.

This is followed by a conventional grating to disperse overlapping orders in the horizontal direction and produce a 2D spectrum of the input light. LightMachinery's software unwraps the spectrum to produce an ultra high resolution wavelength spectrum of the input light.

## Features

- Wavelength range: UV, Visible and NIR (see p4)
- 10-40pm resolution
- Fiber SMF, MMF
- Simple USB interface
- LabView Drivers
- No Moving parts
- Can be triggered externally

## Benefits

- Average range-over-resolution ratio up to 13000
- Ultra compact
- Can measure the spectrum of both CW and pulsed sources
- Single shot acquisition
- Fast, real-time measurements (from a few Hz to 70Hz)
- Ultra reliable
- Easy to calibrate
- LightMachinery's legendary customer support

## Key Technology

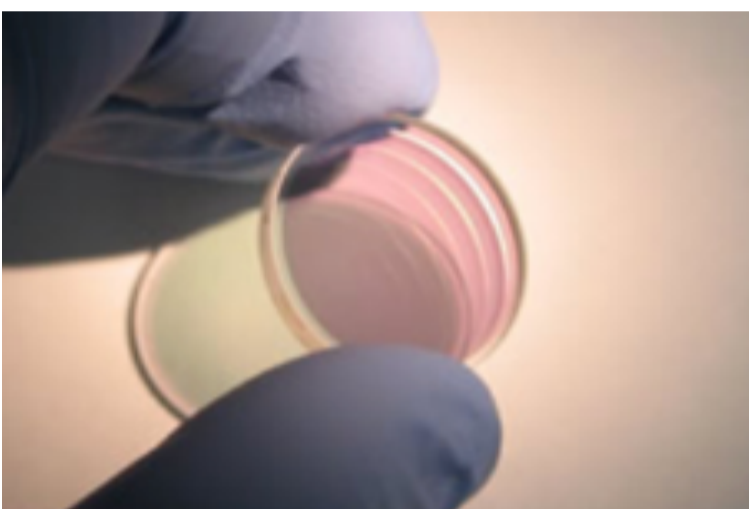

### High Finesse Etalon

The Engine of the Hornet Spectrometer is the high finesse etalon. Our patented fluid jet polishing technology allows us to create surfaces of unmatched parallelism and perfection. Imagine the resolution of a grating spectrometer in a device that fits in your hand, and with single shot acquisition covering the entire wavelength range.

## Applications

### Light Source Measurements

- Lasers of all types
- Superluminescent diodes
- Gas-discharge lamp, etc
- Spectroscopy

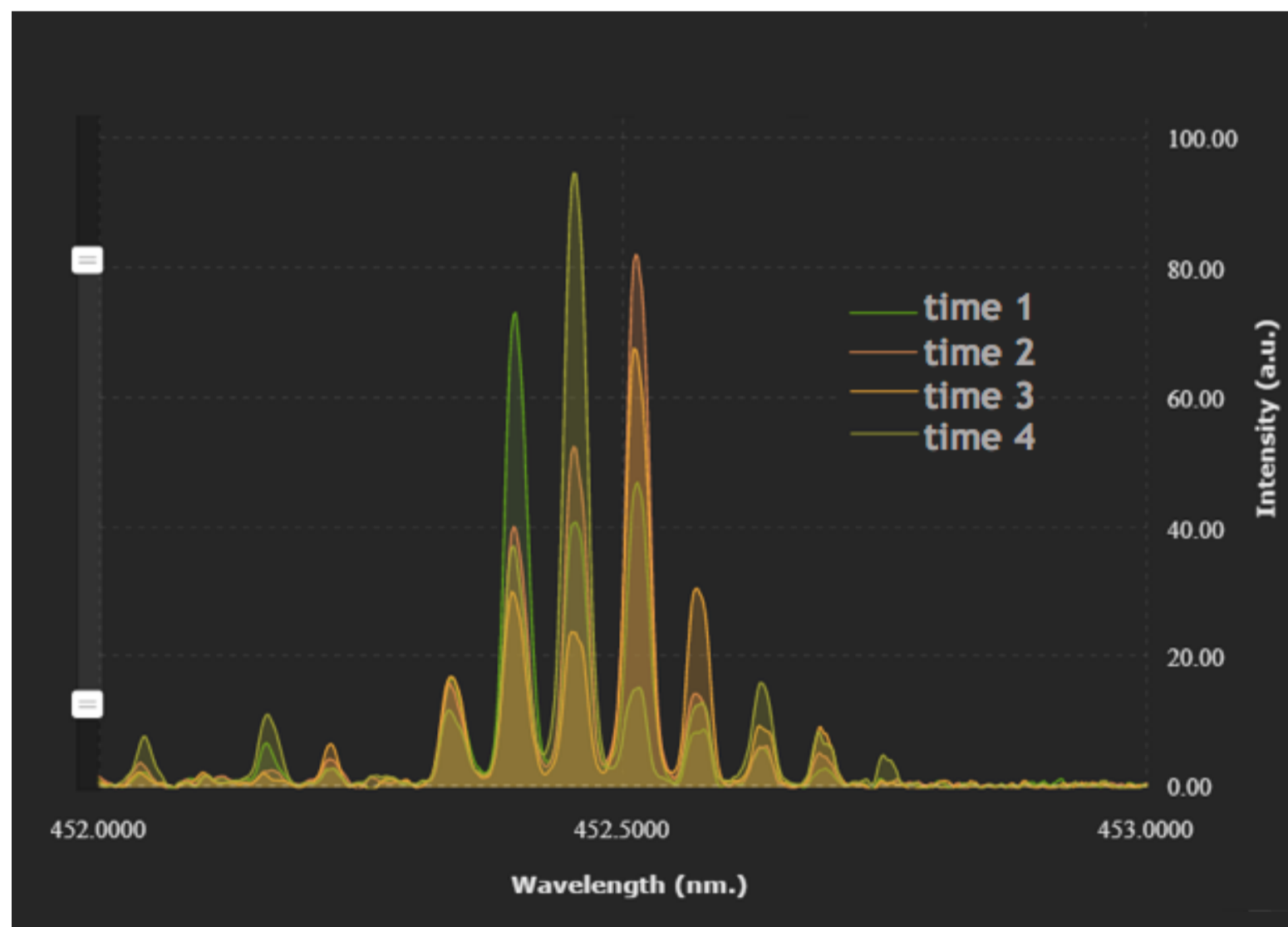

Laser diode: real time mode hopping monitoring

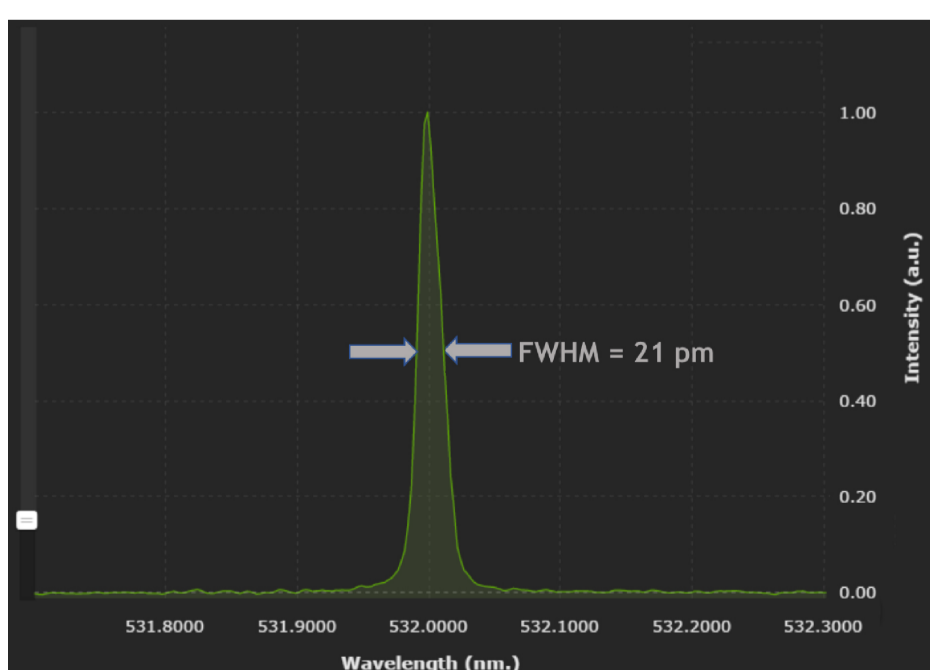

Second harmonic of a single longitudinal mode ytterbium-doped fiber laser

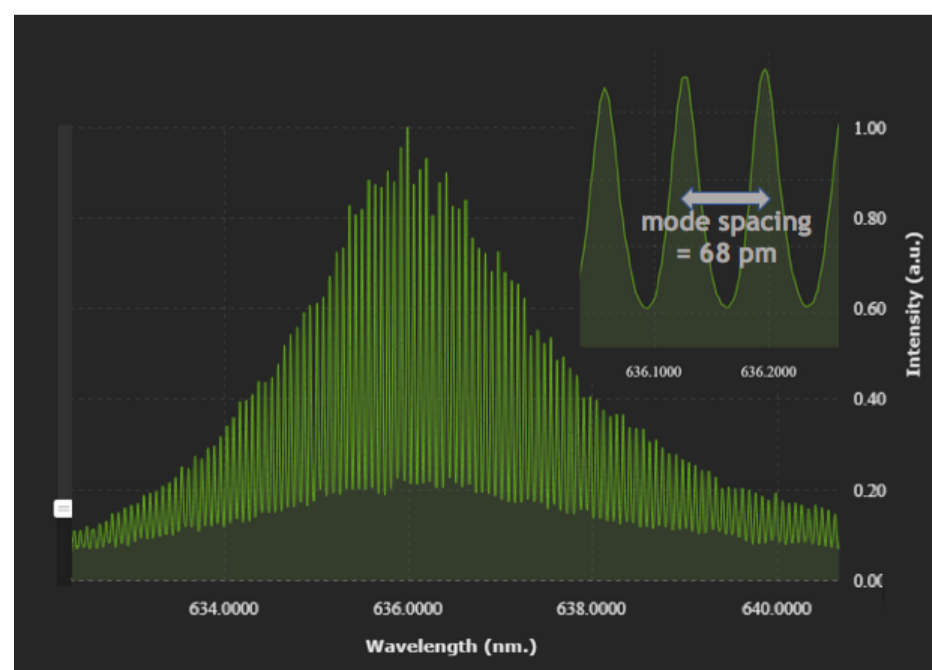

Fabry-Perot semiconductor laser diode just below the threshold

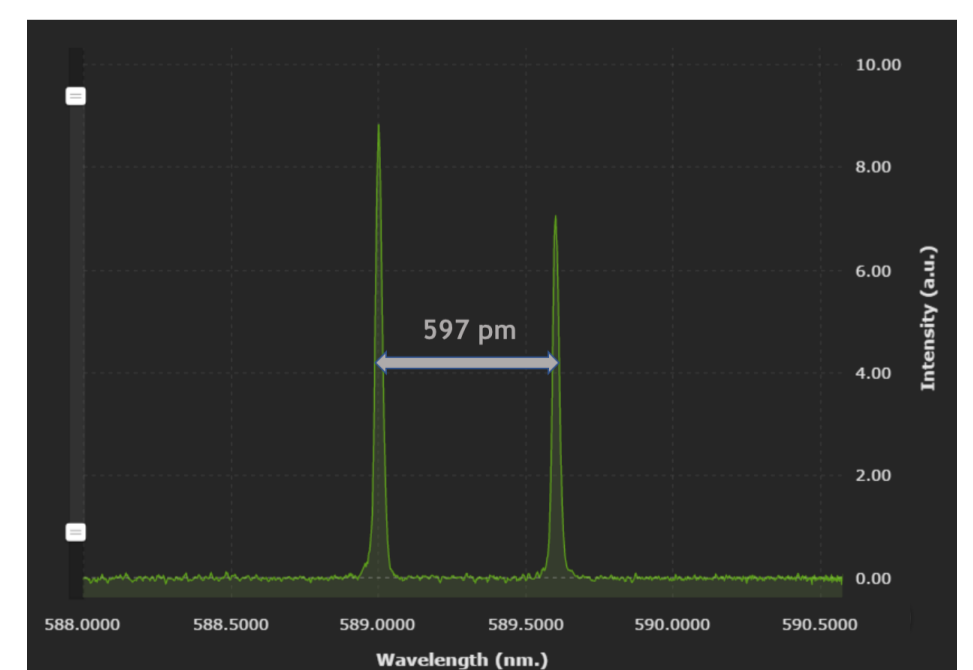

Sodium D-lines

## Passive components characterization and real time monitoring

- Ultra narrow notch and bandpass filters
- Etalons
- Fiber Bragg gratings, etc

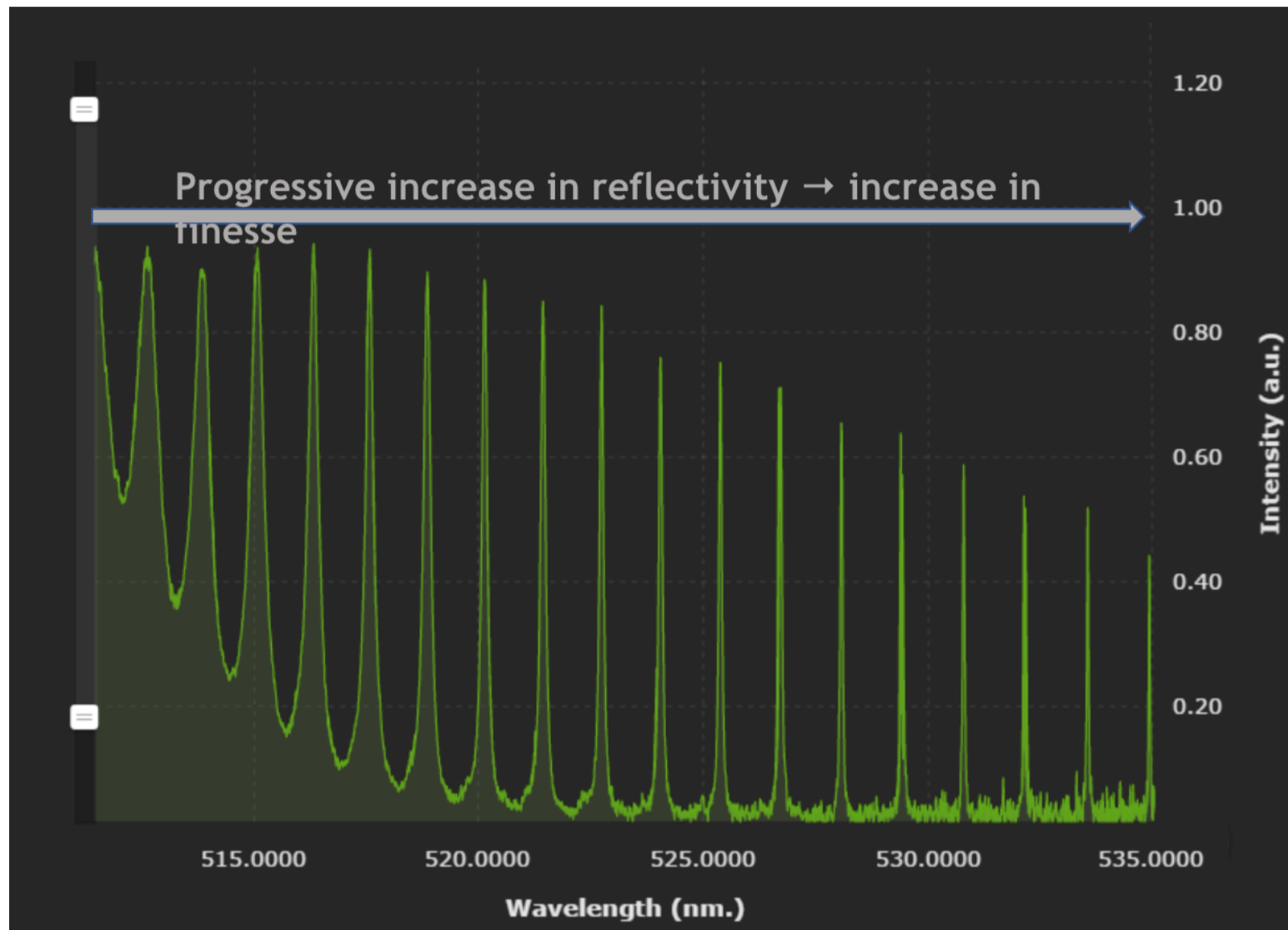

Transmission measurement of a 67  $\mu\text{m}$  thick etalon in a region of non-uniform reflectivity

## Solar spectroscopy

- Monitoring Earth's atmosphere
- Classic undergraduate and graduate experiments

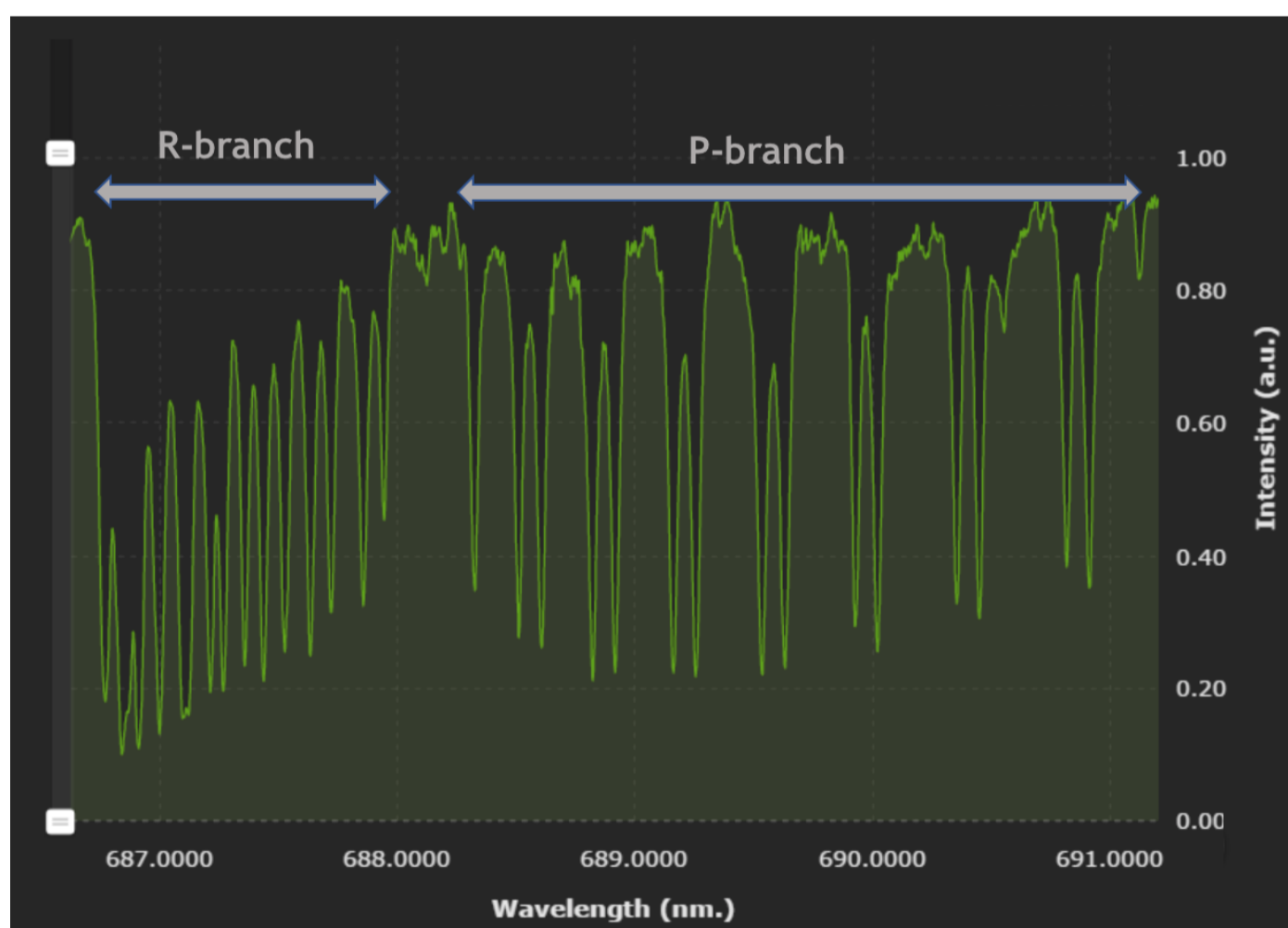

Solar spectrum in a region dominated by the Mg triplet and multiple Fe absorption lines

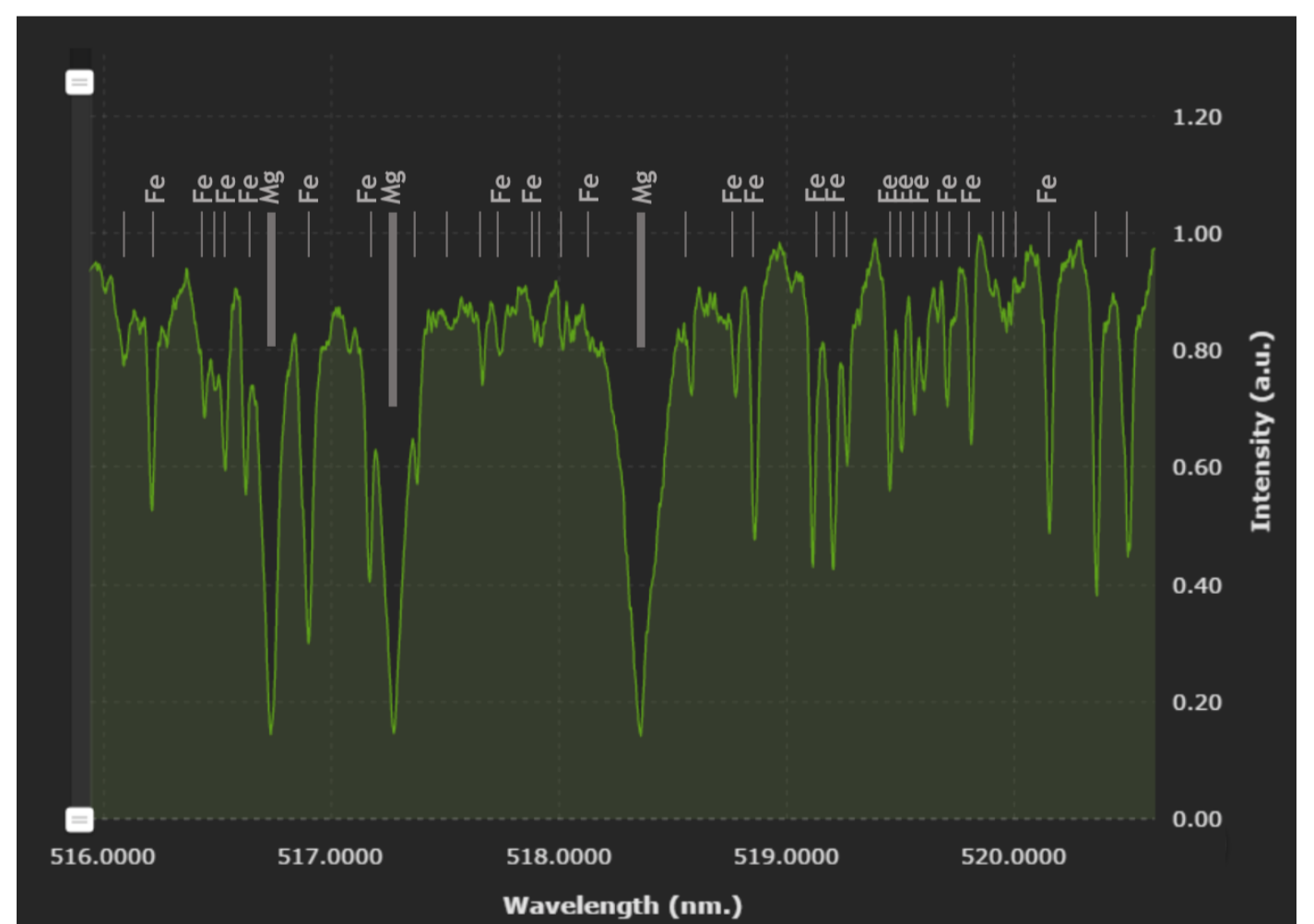

Solar spectrum in a region dominated by multiple O<sub>2</sub> absorption lines

## Models

Part Number	Spectral Region	Wavelength Range (nm)	Resolution (pm)
HN-9340	UV	260-425	15-30
HN-9332	Visible	425-700	15-30
HN-9353	NIR	700-1050	25-40
HN-9350	IR	1525-1575	25*
HN-9352	Visible & IR	YAG, (532 and 1064)+/-2	10

Please contact LightMachinery or your local distributor for prices in your region

\* Qualitative measurements only

## Specifications

- Resolution: sub 20pm at 532nm (resolving power > 25,000)
- Accuracy: < 20pm following calibration
- Dynamic Range: >10<sup>8</sup> for the system, 1000 in a single measurement
- Wavelength range: UV, Visible to near IR (260nm to 16000nm), factory setup from 50nm to 300nm width based on customer's requirements
- Simultaneous range / resolution: >10,000 at 532nm
- Acquisition and processing speed: >10Hz and up to a few hundred Hz over narrow band
- Calibration: a narrow band (<10pm) external reference source is required

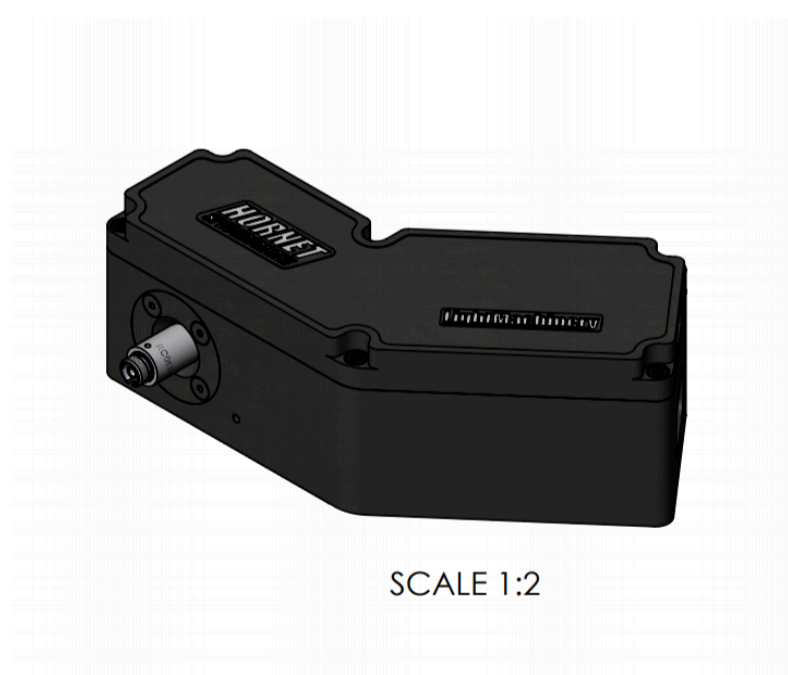

Note: Dimensions in [ ] are millimeters (mm).

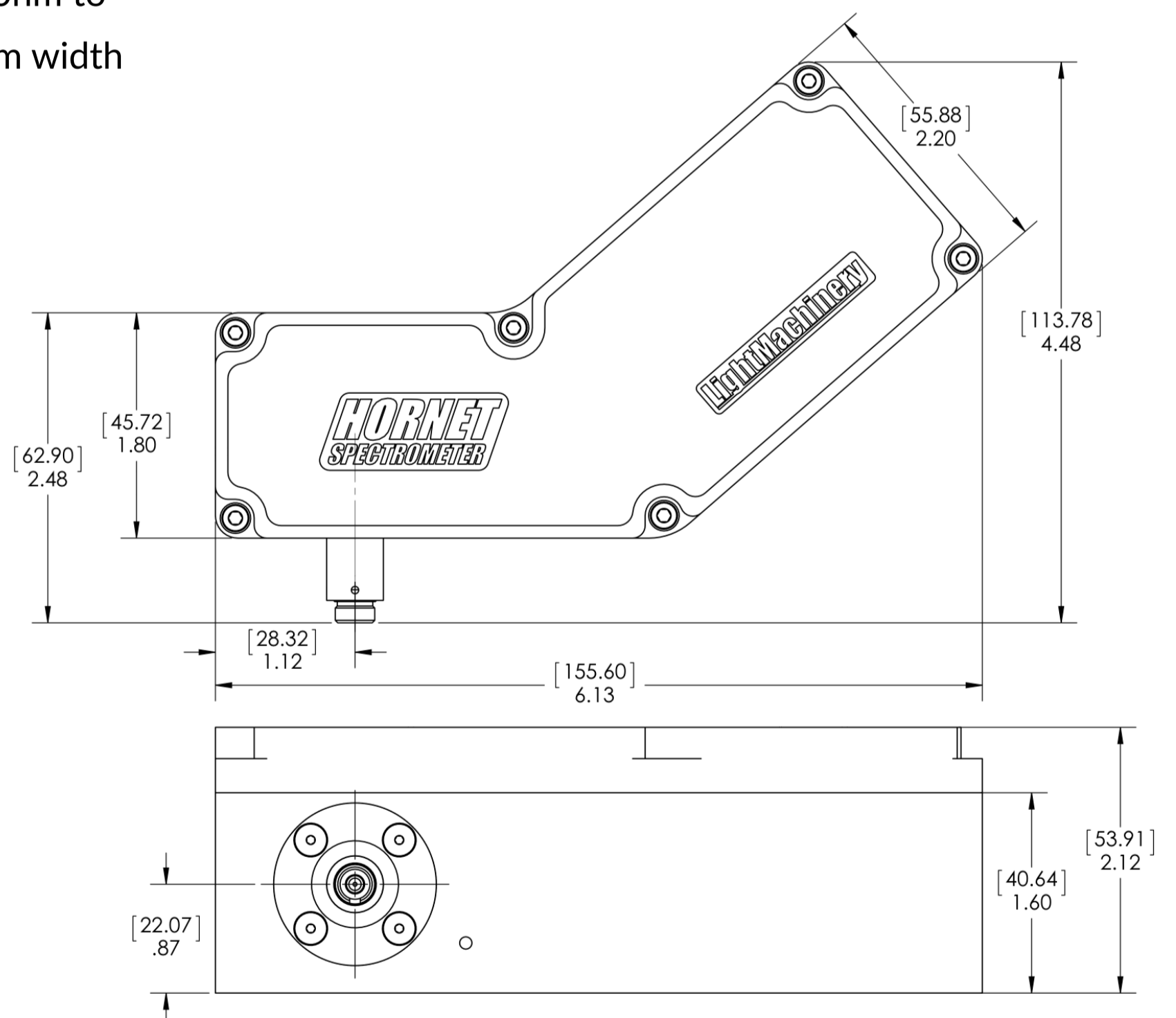

For further technical and sales information, please visit our website or contact:

LightMachinery Inc.

spectrometers@lightmachinery.com

80 Colonnade Road

(613) 749-4895

Ottawa, Ontario, Canada, K2E 7L2