



Femtosecond Fiber Lasers



PErL Fiber Laser

- Small footprint and ruggedized design
- Pulse width from 0.25 to 5 ps available (fixed)
- Near transform-limited output
- Minimal pulse pedestal
- Low timing jitter
- RF synchronization output



PErL Er-doped fiber laser system

Product overview

The smallest but not the least, the PErL laser from Avesta Project is a femtosecond fiber laser operating in C-band (1530-1565 nm). The rigid design of the laser ensures insensitivity to physical and vibration impact, high stability, repeatability of initial specs that is in high demand with OEM applications.

Pulse duration can be ordered in the range of 250 fs - 5 ps, pulse shape being close to transform-limited. The PErL laser with average power rating up to 50 mW is a nice budget-friendly solution for low-power applications, such as amplifier systems seeding. High frequency electrical output of the laser can be used as a trigger for synchronization systems. The laser can act as a stand-alone pulse source, as well as operate in complex systems.

The only thing needed for OEM operation is a power source with +5 V (the power adapter for standard 220/110 V network is supplied with the laser).

Applications:

- OEM integration
- Telecommunication components characterization
- Optical high speed sampling
- Terahertz radiation
- Optical switching
- Materials characterization
- Optical metrology

PErL technical specifications

| | |
|-----------------------------------|------------------------------|
| Available pulse width (fixed), ps | <0.25 - 5 |
| Wavelength (fixed), nm | 1560±10 |
| Average output power, mW | >50 |
| Repetition rate (fixed), MHz | 60±5 |
| Output type | FC/APC fiber socket |
| Polarization extinction ratio, dB | not applicable |
| RF sync out | SMA (200-300 mV@50 ohm load) |
| Dimensions, mm | 136 x 76 x 24 (27) |
| Power supply | +5 V |

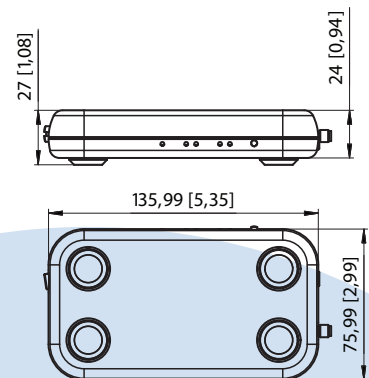

PErL (mm [inches])