

Rock™ High Power Laser Source

High-Power Single-frequency Fiber Laser



Features

- Power up to 5W
- Narrow Linewidth <700Hz
- Ultra-Low Phase-Noise
- Excellent Frequency Stability
- Broad Mode-Hop-Free Tunability
- Low Sensitivity to Acoustic Noise

Mechanical Outline:

High Power Rock Source

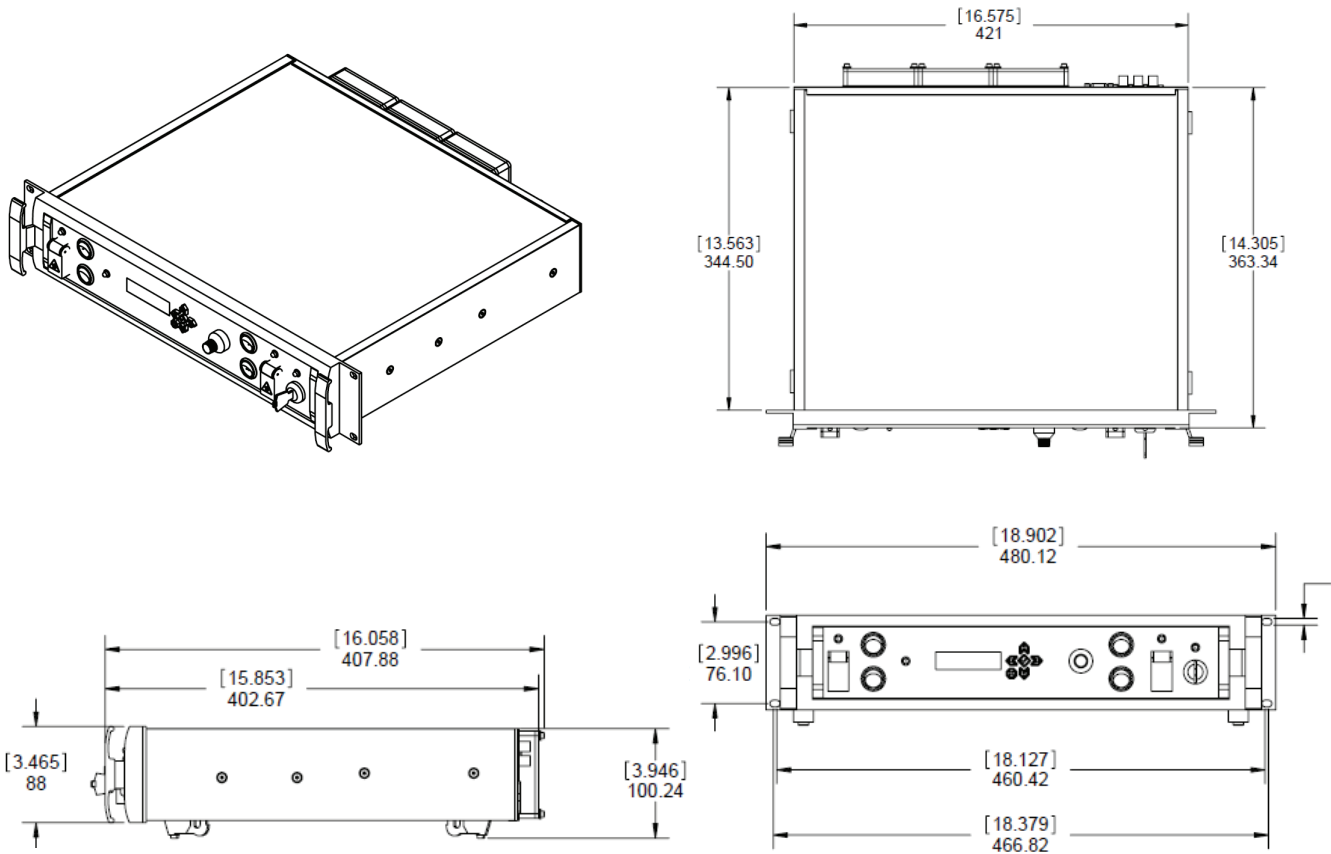

DIMENSIONS ARE IN MILLIMETERS, DIMENSIONS IN [XXX] ARE IN INCHES.

Performance | Reliability | Innovation

