

LASAG QFS 50

Fiber Laser Processing System
for scribing applications

- Scribing of connecting rod eyes from motorbikes to trucks
- Scribing of whole engine blocks
- Scribing of crank shaft bearings

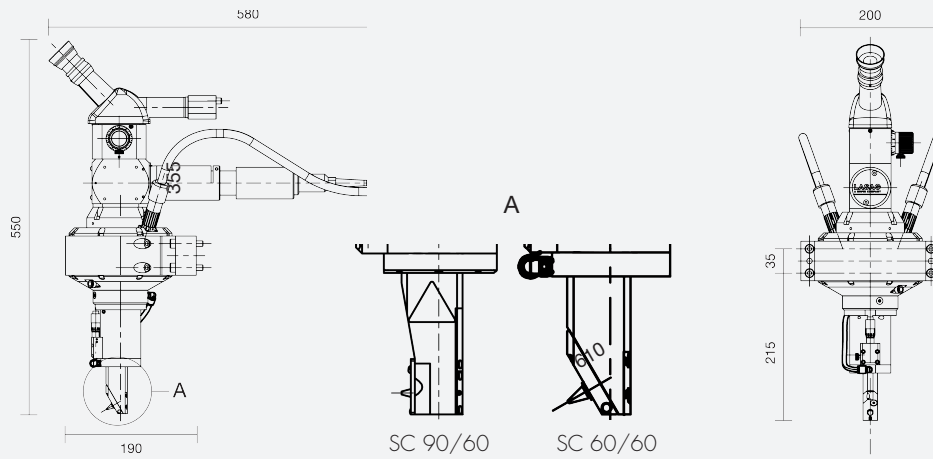



rofin

LASAG QFS 50

Laser source	QFS 50
Laser type	fiber laser
Wavelength	1055 - 1070 nm
Repetition rate	50 - 200 kHz
Pulse duration	150 - 200 ns
Operation mode	Q-switched / pulsed
Output power	50 W
Long-term stability	± 1 %
Red aiming beam	< 0.2 mW
Optical fiber cable	4.7 m, non-detachable
Minimal bending radius	100 mm
Processing head	FLBK SC 90/60 or FLBK SC 60/60
Dimensions processing head	200 x 540 x approx. 550 mm (w x h x d)
Weight processing head	approx. 9 kg
Motor type	torque motor
Conrod eye	diameter > 35 mm, thickness < 60 mm
Gas nozzle diameter	0.5mm / 1mm
Gas pressure	3 bar typ. / 6 bar max.
Gas type	dry, oil free compressed air
Processing angle	60° or 90°
Rotating angle	programmable
Viewing	45° monocular
Supply Cabinet	
Dimensions housing	600 x 660 x 950 mm (w x h x d)
Laser unit QFS 50	19" rack-mount, 6 HU
User interfaces laser unit	RS 232 / digital / TCP / IP / Profibus
Motor control unit	19" rack-mount, 3 U
User interfaces driver unit	digital / RS 232 (for configuration)
Total weight	approx. 90 kg (Cabinet), 21 kg (19" Rack)
Protection rating	IP54
Installation and ambient conditions	
Supply voltage	100 - 230 V ± 10%, 50 - 60 Hz, 1P + E
Power consumption, max.	approx. 900 W typ.
Cooling	air-cooled
Ambient temperature max.	10 - 35 °C. (full power)
Relative humidity max.	20 - 90% (non condensing)
PC for configuration	customer supplied
Options	
CCD camera, Profibus for motor driver unit	
Compliance with standards	
CE compliant, FDA compliant	

Switzerland
ROFIN-LASAG AG
 C.F.L. Lohnerstrasse 24
 3645 Gwatt (Thun)
 Switzerland
 Phone: +41 33 227 45 45
 Fax: +41 33 227 45 73
 lasers@lasag.ch
 www.lasag.com

Germany
ROFIN-BAASEL Lasertech
 GmbH & Co.KG
 Petersbrunner Str. 1b
 82319 Starnberg
 Germany
 Phone: +49 8151 776 0
 Fax: +49 8151 776 4159
 sales@baasel.de

USA
ROFIN-LASAG Laser
 1617 Barclay Boulevard
 Buffalo Grove, IL 60089
 USA
 Phone: +1-847-483 6300
 Fax: +1-847-483 6333
 lasers@lasag.com



Specifications subject to change without notice

SWISS PRECISION 