



PART NUMBER 0532L-14B
 ITEM NAME 532 NM LASER (DPSS; MM FIBER)

PRODUCT DATASHEET



DESCRIPTION

Very compact 532 nm DPSS laser module features high output power, very good beam quality and superior long-term power stability. 532 nm wavelength radiation is commonly used in fluorescence excitation, scanning microscopy and general green light illumination.

SPECIFICATIONS

Specifications updated: 17 August 2020

Parameter	Minimum Value	Typical Value	Maximum Value
Central Wavelength, nm	532	532.1	532.2
Longitudinal modes	-	Multiple	-
Spectral line width FWHM, nm	0.02	0.1	0.5
Output power, mW	-	160 ¹	200
Power stability, % (RMS, 8 hrs)	0.05	1 ²	0.5
Power stability, % (peak-to-peak, 8 hrs)	0.2	0.5 ³	3
Noise, % (RMS, 20 Hz to 20 MHz)	0.5	3 ⁴	30
Transversal modes	-	Multiple	-
Control interface type	-	UART ⁵	-
Operation mode	-	APC (CW)	-
Modulation bandwidth, MHz	-	N/A ⁶	-
Input voltage, VDC	4.8	5	5.3
External power supply requirement	-	+5 V DC, 5A	-
Dimensions, mm	-	50 x 30 x 18 ⁷	-
Fiber Length, m	0.95	1	1.1
Heat-sinking requirement, °C/W	-	0.5	-
Optimum heatsink temperature, °C	15	20	30
Warm up time, mins (cold start)	0.2	1	2
Temperature stabilization	-	Internal TEC	-
Overheat protection	-	Yes	-
Storage temperature, °C (non-condensing)	-10	-	50
Net weight, kg	0.1	0.12	0.14
Max. power consumption, W	5	10	20

TYPICAL SPECTRUM

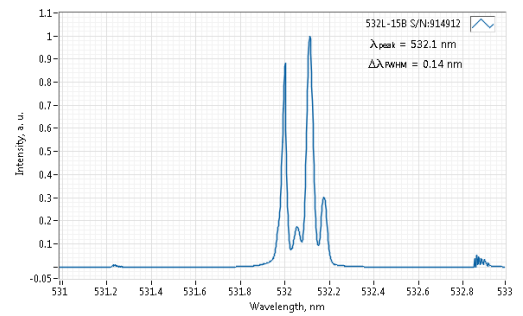

Typical spectrum of 0532 nm DPSS laser. Measured with 20 pm resolution.

TYPICAL NEAR FIELD

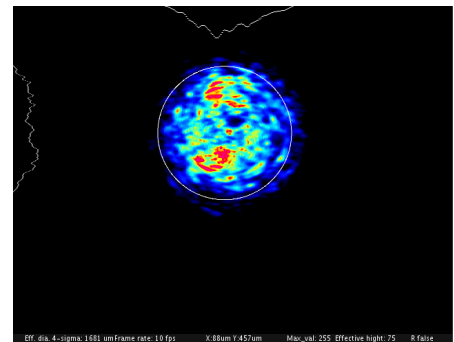

Warranty, months (op. hrs)	-	14 (10000) ⁸	-
Residual IR wavelength contrast	-	20	-
RoHS	-	Yes	-
CE compliance	-	- General Product Safety Directive (GPSD) 2001/95/EC - (EMC) Directive 2004/108/EC	-
Laser Safety Class	-	3B	-
OEM lasers are not compliant with	-	IEC60825-1:2014 (compliant using additional accessories)	-
Country of origin	-	Lithuania	-

DRAWING

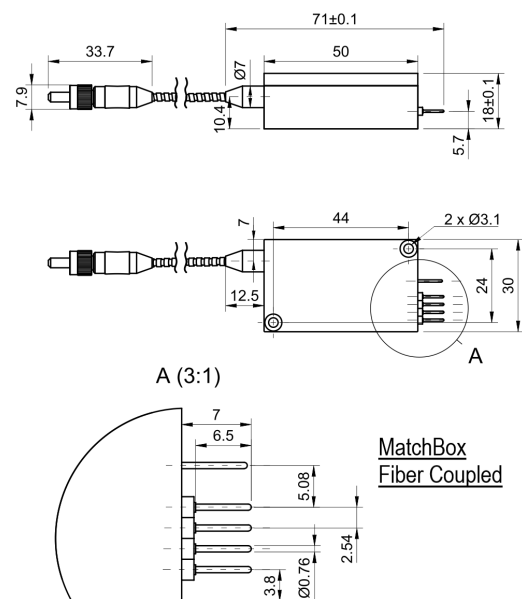

¹ The optical power can be tuned from virtually 0% to 100%. However, other specifications, such as central wavelength, power stability, noise, polarization ratio, beam shape, quality and circularity are not guaranteed at power levels other than factory preset power. Significantly worse power stability is to be expected at very low power levels, e.g. <3% from specified nominal power.

² The long term power test is carried out at constant laser body temperature (+/-0.1 °C) using an optical power meter with an input bandwidth of 10 Hz. The actual measurement rate has a period of about 20 seconds to 1 minute.

³ The long term power test is carried out at constant laser body temperature (+/-0.1 °C) using an optical power meter with an input bandwidth of 10 Hz. The actual measurement rate has a period of about 20 seconds to 1 minute.

⁴ Noise level is measured with a fast photodiode connected to an oscilloscope. The overall system bandwidth is from 2 kHz to 20 MHz.

⁵ Break-out-boxes AM-C8 and AM-C3 can be used for conversion of UART communication to either USB or RS232.

⁶ Slow TTL modulation can be enabled on request.

⁷ Excluding control interface pins and an output window/fiber assembly.

⁸ Whichever occurs first. The laser has an integrated operational hours counter.

Note: Product specifications are subject to change without prior notice to improve reliability, function or design or otherwise.