



Verdi G SLM-Series

Single-Frequency Visible Lasers for Scientific and Research Applications

Applications such as spectroscopy, interferometry, and holography require single-frequency lasers with narrow linewidths and long coherence lengths. The Verdi G SLM-Series provides up to 5W of single-frequency 532 nm laser light in a simple, CDRH-compliant turnkey system.

Based on Coherent's unique Optically Pumped Semiconductor Laser (OPSL) technology, the Verdi G SLM-Series features single-frequency operating for the most demanding of applications. This, combined with stable beam parameters across output power, a diffraction-limited beam, low-noise, and high stability, provides unparalleled laser performance in a convenient package.

The Verdi G SLM-Series is the perfect match for customers in need of the highest performing 532 nm CW laser technology for scientific and research applications.

FEATURES

- Single Longitudinal Mode at 2W and 5W
- Extremely low-noise performance
- Superior mode quality
- OPSL reliability

APPLICATIONS

- Ti:Sapphire Pumping
- Holography
- Interferometry
- Raman Spectroscopy
- Laser Inspection



SPECIFICATIONS ¹	Verdi	
	G2	G5
Wavelength (nm)	532 ±2	
Pulse Format	CW	
Linewidth ² (MHz)	<5	
Spectral Purity (%)	>99	
Output Power ³ (W)	2	5
Spatial Mode	TEM ₀₀	
Beam Quality	<1.1	
Beam Circularity ⁴	1.0 ±0.1	
Beam Waist Diameter (mm) (FW, 1/e ²)	2.25 ±10%	
Beam Divergence (mrad) (FW, 1/e ²)	<0.5	
Beam Waist Location ⁵ (m)	±0.5	
Beam Pointing Stability ⁶ (μrad/°C)	<2	
Horizontal Beam Position Tolerance ⁷ (mm)	±<1.0	
Vertical Beam Position Tolerance ⁷ (mm)	±<1.0	
Polarization Ratio	Linear, >100:1	
Polarization Direction	Vertical, ±5°	
Noise (% rms) (10 Hz to 100 MHz)	<0.03	<0.02
Power Stability ⁸ (%) (pk-pk)	±<1	
Warm-up Time (minutes)	<10	
CDRH Compliant	Yes	
ELECTRICAL SPECIFICATIONS		
Operating Voltage (VAC)	100 to 240	
Frequency (Hz)	50 to 60	
Power Consumption (W)	500	
ENVIRONMENTAL CONDITIONS		
Ambient Temperature (°C)		
Operating	10 to 40	
Non-Operating	-10 to 60	
Relative Humidity ⁹ (%)	5 to 95	
CE Marking	IEC 61010-1/EN 61010-1	
Dimensions (L x W x H)		
Laser Head ¹⁰	281 x 156 x 85 mm (11.06 x 6.14 x 3.35 in.)	
Benchtop Controller	361 x 229 x 160 mm (14.22 x 9.01 x 6.29 in.)	
Cables (laser head to controller)	3m (10 ft.)	

¹ Optical parameters measured at the output plane of the laser head, unless noted all parameters valid at the nominal output power and for the lifetime of the unit.

² Measured over 50 msec.

³ This product is offered in several output power versions: 2W and 5W. The output power can be adjusted from 250 mW to maximum power.

⁴ Circularity defined as vertical diameter divided by horizontal diameter.

⁵ Negative value corresponds to a location inside head.

⁶ After 2-hour warm-up.

⁷ Measured at the output window.

⁸ Measured over 8 hrs.

⁹ Non-condensing.

¹⁰ Back connector not included in laser head length dimension.

MECHANICAL SPECIFICATIONS

Laser Head

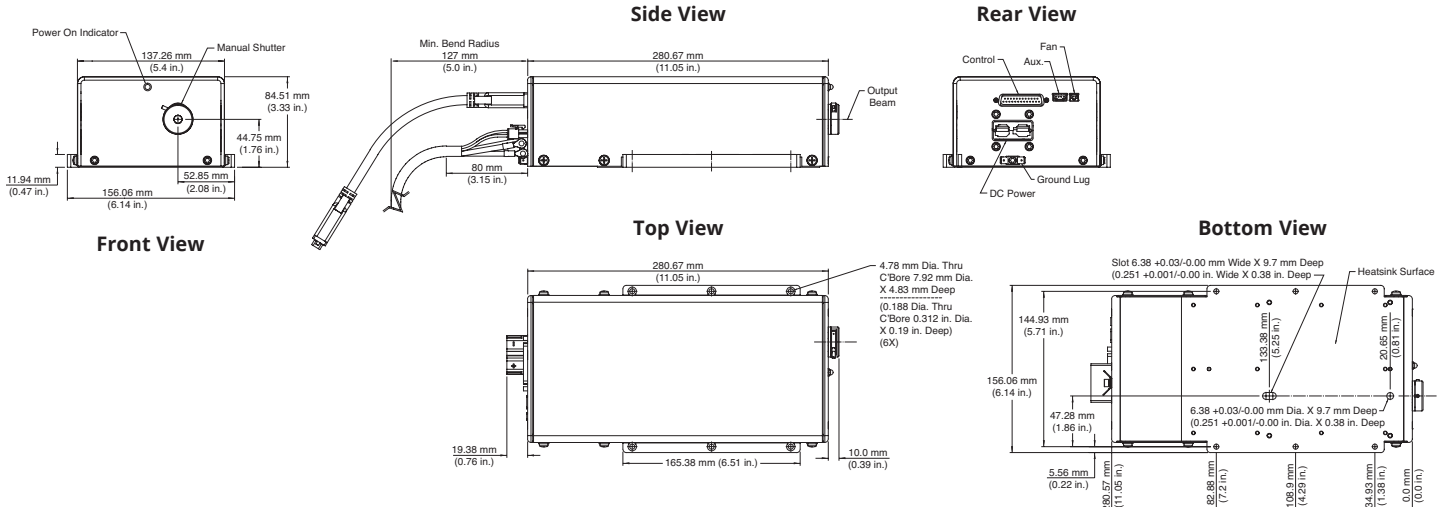

Power Supply

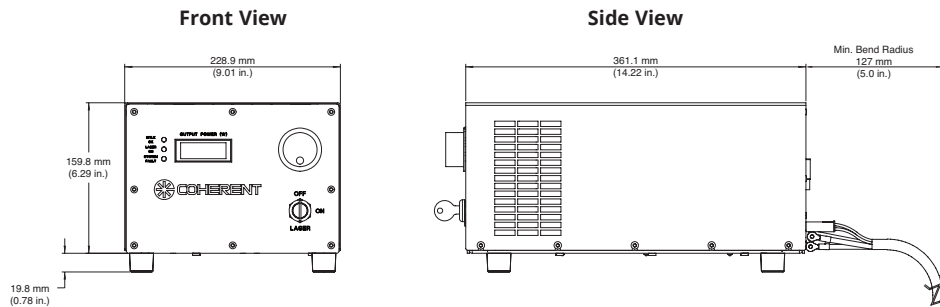

Coherent, Inc.,
 5100 Patrick Henry Drive Santa Clara, CA 95054
 p. (800) 527-3786 | (408) 764-4983
 f. (408) 764-4646

tech.sales@Coherent.com www.Coherent.com

U.S. Patent No. 5,991,318
 U.S. Patent No. 6,167,068
 U.S. Patent No. 6,285,702
 U.S. Patent No. 6,438,153
 U.S. Patent No. 6,683,901
 U.S. Patent No. 7,180,928



Coherent follows a policy of continuous product improvement. Specifications are subject to change without notice. Coherent's scientific and industrial lasers are certified to comply with the Federal Regulations (21 CFR Subchapter J) as administered by the Center for Devices and Radiological Health on all systems ordered for shipment after August 2, 1976.

Coherent offers a limited warranty for all Verdi G lasers. For full details of this warranty coverage, please refer to the Service section at www.Coherent.com or contact your local Sales or Service Representative. Printed in the U.S.A. MC-010-12-0M0917Rev.B Copyright ©2017 Coherent, Inc.

