

Sub-Nanosecond Diode Pumped Passively Q-Switched Laser

MPL1510-FC

FEATURES

- > Up to 1 mJ pulse energy at 1064 nm
- > Short pulse duration < 600 ps
- > Variable up to 100 Hz repetition rate
- > Ultra-compact
- > Passively Q-switched
- > Average power 100 mW
- > High peak power 2 MW
- > Guaranteed > 3 Gshot lifetime
- > Other wavelengths (e.g. 1342 nm, 671 nm, 447 nm) are available

APPLICATIONS

- > Nonlinear Optics
- > Laser-Induced Breakdown Spectroscopy (LIBS)
- > Time Resolved Fluorescence Measurements
- > DNA Analysis
- > Pollution Monitoring
- > Remote sensing
- > Supercontinuum Generation
- > Ignition of Gas Mixtures

MPL1510 series DPSS passively Q-switched sub-nanosecond lasers deliver high peak powers at 100 Hz repetition rate. Short laser cavity with the fiber pumped technology is fixed on thermo-stabilized and controlled baseplate which gives extremely stable output parameters performance. Small footprint is welcome point for integration into OEM lasers. Sub-nanosecond pulse duration of < 600 ps, high pulse energy more than 1 mJ, variable repetition rate from 1 to 100 Hz covers many applications like pollution monitoring, DNA analysis, supercontinuum generation and many others.

Different models operate with repetition rates up to 100 Hz and the average power ranges



from 100 to 250 mW. Optional conversion to green (532 nm) and ultraviolet (355 & 266 nm) is also available.

Specifications ¹⁾

MODEL	MPL1510-FC
Wavelength	1064 nm
Pulse energy	1 mJ
Typical pulse duration	< 600 ps ²⁾
Pulse to pulse energy stability	< 0.5 % RMS ³⁾
Power drift	± 3.0 % ⁴⁾
Pulse repetition rate ⁵⁾	1 – 100 Hz
Beam profile	Bell-shaped, > 85 % fit to Gaussian
Beam divergence ⁶⁾	< 4 mrad
Polarization	Linear, horizontal at 1064 nm
Spectral Linewidth	SLM
Beam pointing stability ⁷⁾	< 40 µrad
Typical beam diameter ⁸⁾	~ 1 mm
Jitter	~ 2 µs RMS ⁹⁾

DIMENSIONS	
Laser head (W×L×H)	80 × 102 × 36 mm
Controller unit (W×L×H)	108 × 191 × 59 mm
Power adapter, typical (W×L×H)	50 × 125 × 31 mm

OPERATING REQUIREMENTS	
Cooling requirements	Air cooled
Ambient temperature	15 – 30 °C
Relative humidity (non-condensing)	10 – 80 %
Mains voltage	90 – 230 VAC, single phase, 47 – 63 Hz ¹⁰⁾
Power consumption	< 10 W

- ¹⁾ Due to continuous improvements all specifications are subject to change. Unless stated otherwise all specifications are measured at 1064 nm
- ²⁾ FWHM level at 1064 nm. Shorter pulse duration (< 350 ps) is available by request. Please inquire for detailed specifications.
- ³⁾ Averaged from 60 seconds time interval.
- ⁴⁾ Over 8-hour period after max 5 minutes of warm-up when ambient temperature variation is less than ±2 °C.
- ⁵⁾ Factory-set pulse repetition rate is fixed at max repetition rate. Higher repetition rates are available, please inquire for details.
- ⁶⁾ Full angle measured at the 1/e² level.
- ⁷⁾ RMS value measured from 1000 shots.
- ⁸⁾ Beam diameter is measured 20 cm from laser output at the 1/e² level.
- ⁹⁾ In respect to Q-switch triggering rising edge pulse.
- ¹⁰⁾ Laser can be powered from appropriate 12 VDC power source. Inquire for details.

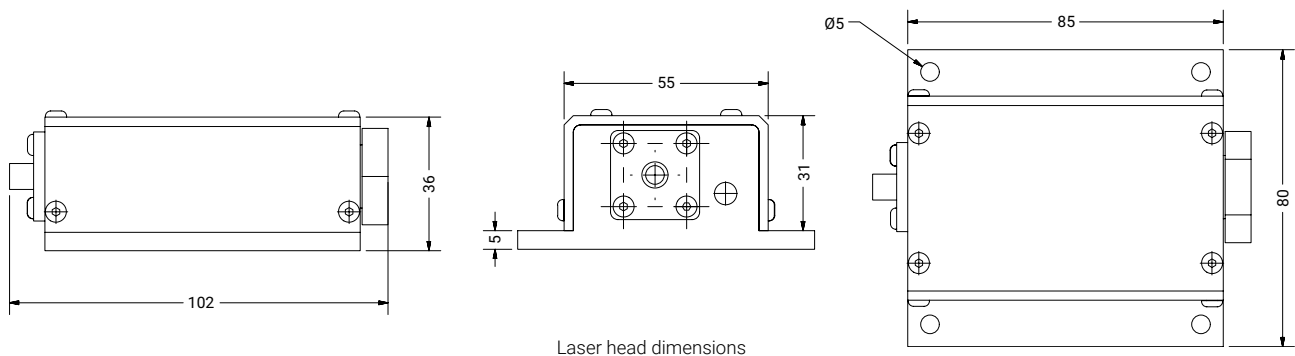

Laser head dimensions

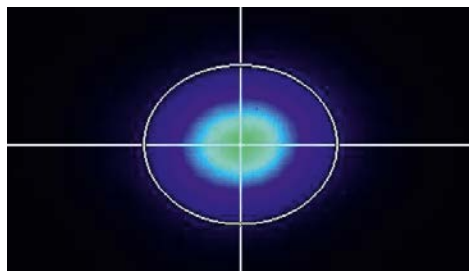

Typical beam intensity profile (20 cm from laser output) of MPL1510 series lasers

