

High-Performance Long-Travel Linear Motor Stages

IMS-LM SERIES



The IMS-LM series of linear motor stages are designed for self-supporting applications with travel ranges from 300 mm to 1200 mm. The stages feature a robust design with high performance at low cost, making them cost-effective solutions for precision industrial applications such as semiconductor wafer inspection, microelectronics test and assembly, pick and place, DNA sequencing, or laser machining. The IMS-LM-SA version with 4-point mounting, is ideal for delay lines and other applications with non-flat mounting surfaces.

The IMS-LM series utilizes an FEM optimized extruded aluminum body that is extremely stiff and minimizes bending caused by different thermal expansion coefficients of the aluminum body and steel rails.

Unlike-screw driven stages, the IMS-LM employs a center-driven linear motor. This linear motor is absolutely noise-free and has the advantage of higher speed, acceleration and system responsiveness without wear on motor brushes or drive screws. Due to the fully integrated linear motor, the IMS-LM is more than 100 mm shorter in length than a comparable screw driven stage. Thus, the IMS-LM is the optimum solution for space constrained applications that require high-throughput, high reliability, and ultra-quiet operation.

The IMS-LM uses a high efficiency 3-phase synchronous ironcore linear motor. While ironcore linear motors are often criticized for their cogging and high attractive forces, their efficiency is almost twice the efficiency of ironless linear motors. This results in higher acceleration capability and significantly less heat generation, which often limits performance of rapid point-to-point positioning.

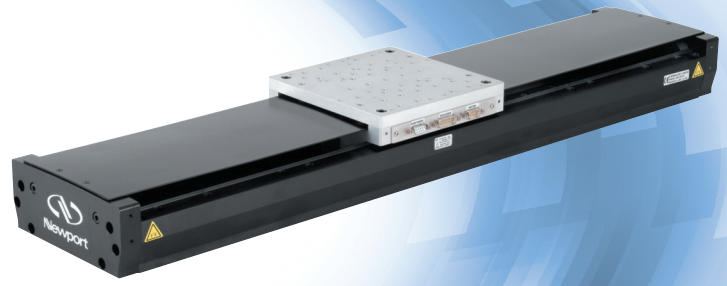

- Non-contact direct-drive system for high dynamic response & high reliability
- High-efficiency ironcore linear motor for rapid and repeatable positioning
- High resolution linear encoder for sub- μm repeatability & 20 nm MIM
- Stiff body design for rigid XY assemblies up to 600 x 600 mm travel
- Recirculating bearings with caged balls assure ultra-quiet motion

DESIGN DETAILS

Base Material	Extruded Aluminum
Bearings	Recirculating bearings with caged balls
Drive System	3-phase synchronous ironcore linear motor (no Hall effect sensors)
Motor Initialization	Has to be done by the controller (without using Hall effect sensors)
Feedback	Linear steel scale, 20 μm signal period, 1 Vpp
Limit Switches	Optical
Home Switch	Optical, on encoder's fiducial track, located at center of travel
ESP Compatibility	Yes
Cable	5 m long cables included
MTBF	20,000 hours

IMS-LM SERIES

Recirculating ball bearing slides with caged balls provide excellent payload capacity and long life. The ball separators in the recirculating elements ensure superior smooth movement, lower noise, and longer service life compared to uncaged ball bearing slides.

Precision position feedback is supplied by a highly repeatable linear scale mounted inside the stage. The encoder signals are interpolated by Newport's motion controllers with outstanding 20 nm Minimum Incremental Motion, repeatability, and stability. Absolute home position and limit signals are incorporated to improve repeatability and reliability, while simplifying the design with less electronics and mechanical parts .

SPECIFICATIONS

	Travel Range (mm)	IMS-LM	IMS-LM-SA
Travel Range (mm)		300, 400, 500, 600, 800, 1000 and 1200	800, 1000 and 1200
Minimum Incremental Motion (nm)		20	
Bidirectional Repeatability, Typical (Guaranteed) ⁽¹⁾ (μm)	300 & 400:	±0.08 (±0.25)	–
Typical (Guaranteed) ⁽¹⁾ (μm)	500 & 600:	±0.09 (±0.25)	–
	800:	±0.10 (± 0.50)	±0.10 (± 0.50)
	1000:	±0.12 (± 0.50)	±0.12 (± 0.50)
	1200:	±0.13 (± 0.50)	±0.13 (± 0.50)
Accuracy, Typical (Guaranteed) ⁽¹⁾ (μm)	300:	±1.7 (±4.5)	–
	400:	±2.0 (±4.5)	–
	500:	±2.5 (±5.5)	–
	600:	±3.0 (±7.5)	–
	800 & 1000:	±4.0 (±9.0)	±4.0 (±9.0)
	1200:	±5.0 (±9.0)	±5.0 (±15)
Maximum Speed (No Load) ⁽²⁾ (mm/s)		1000 (refer to chart below)	
Maximum Acceleration (No Load) ⁽²⁾ (m/s ²)		40	
Moving mass (kg)		Carriage: 3.5 + Interface:1 = 4.5	
Drag force (torque)		Approx. 15 N	
Pitch, Typical (Guaranteed) ⁽¹⁾⁽³⁾ (μrad)	300 to 500:	±37 (±75)	–
	600:	±50 (±125)	–
	800:	±100 (±200)	±100 (±200)
	1000:	±112 (±225)	±112 (±225)
	1200:	±125 (±250)	±125 (±250)
Yaw, Typical (Guaranteed) ⁽¹⁾⁽³⁾ (μrad)	300:	±25 (±50)	–
	400 & 500:	±25 (±75)	–
	600:	±30 (±75)	–
	800 to 1200:	±40 (±150)	±40 (±150)

¹⁾ Shown are peak to peak, guaranteed specifications or ±half the value as sometimes shown. For the definition of typical specifications which are about 2X better than the guaranteed values, visit www.newport.com for the Motion Control Metrology Primer.

²⁾ Speed depends on the driver.

³⁾ To obtain arcsec units, divide μrad value by 4.8.

LOAD CHARACTERISTICS AND STIFFNESS

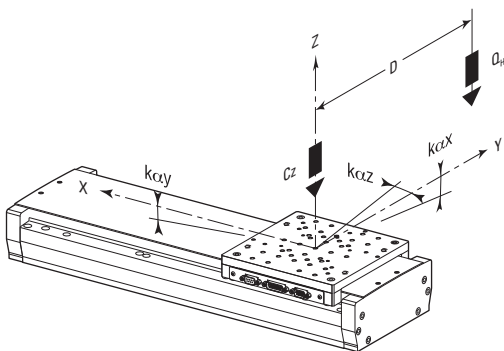

	IMS-LM	IMS-LM-SA
C _z , Normal center load capacity on bearings	600 N	100 N
k _{cxx} , Angular stiffness (Roll)	1 μrad/Nm	2 μrad/Nm
k _{cxy} , Angular stiffness (Pitch)	0.2 μrad/Nm	2 μrad/Nm
k _{ccz} , Angular stiffness (Yaw)	1 μrad/Nm	1 μrad/Nm
Q, Off-center load	Q ≤ C _z / (1 + D/90)	
with D = Cantilever distance in mm		

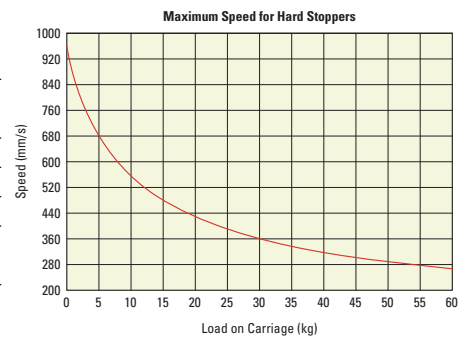

DIMENSIONS

(M-)IMS-LM(-SA) Stages

MODEL SHOWN: IMS300LM
DIMENSIONS IN INCHES (AND MILLIMETERS)

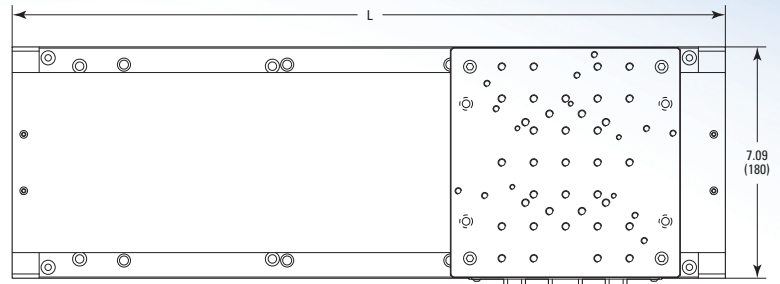

SIDE VIEW
(M-)IMS300LM TO (M-)IMS600LM

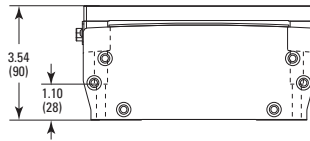

SIDE VIEW
(M-)IMS800LM(-SA) TO (M-)IMS1200LM(-SA)

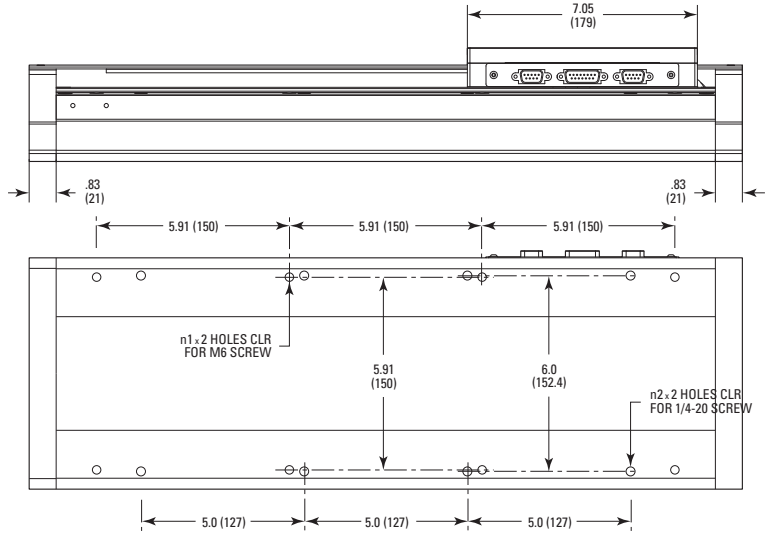
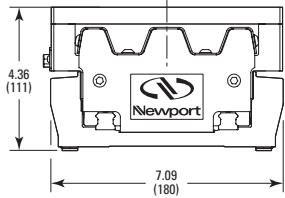

MODEL (METRIC)	n1	n2	TRAVEL	L
(M-)IMS300LM	4	4	11.81 (300)	21.85 (555)
(M-)IMS400LM	4	4	15.75 (400)	25.79 (655)
(M-)IMS500LM	4	6	19.69 (500)	29.72 (755)
(M-)IMS600LM	6	6	23.62 (600)	33.66 (855)
(M-)IMS800LM	6	-	31.49 (800)	44.48 (1130)
(M-)IMS1000LM	7	-	39.36 (1000)	52.35 (1330)
(M-)IMS1200LM	8	-	47.23 (1200)	60.22 (1530)
(M-)IMS800LM-SA	4 HOLES ON 26 x 6 (600 x 150)	-	31.49 (800)	44.48 (1130)
(M-)IMS1000LM-SA	4 HOLES ON 28 x 6 (750 x 150)	-	39.36 (1000)	52.35 (1330)
(M-)IMS1200LM-SA	4 HOLES ON 34 x 6 (900 x 150)	-	47.23 (1200)	60.22 (1530)

VIEW A

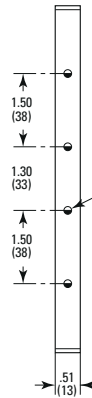

BOTH SIDES:
4 HOLES M4 THD,
DEPTH: .24 (6)

IMS-LM & M-IMS-LM Stages Top Plate Interfaces

MODEL SHOWN: IMS-LM INTERFACE
DIMENSIONS IN INCHES (AND MILLIMETERS)

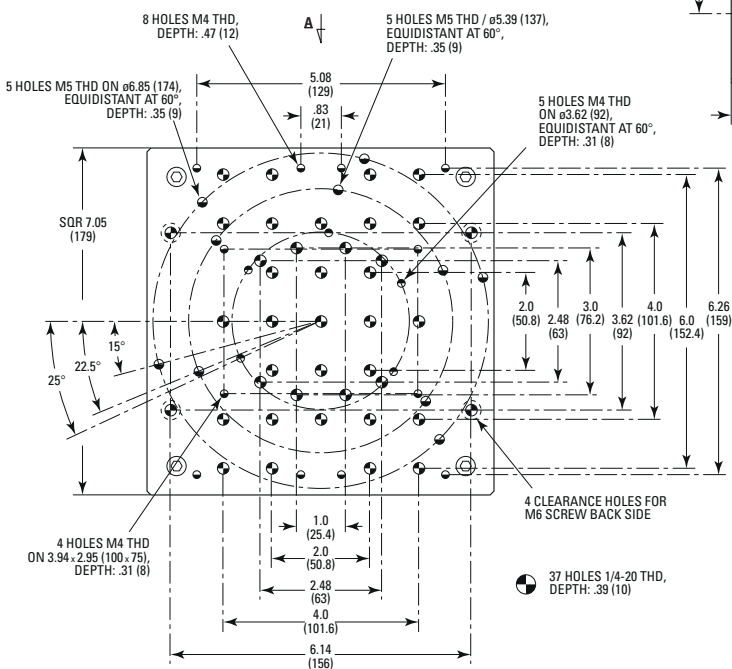

MODEL SHOWN: M-IMS-LM INTERFACE
DIMENSIONS IN INCHES (AND MILLIMETERS)

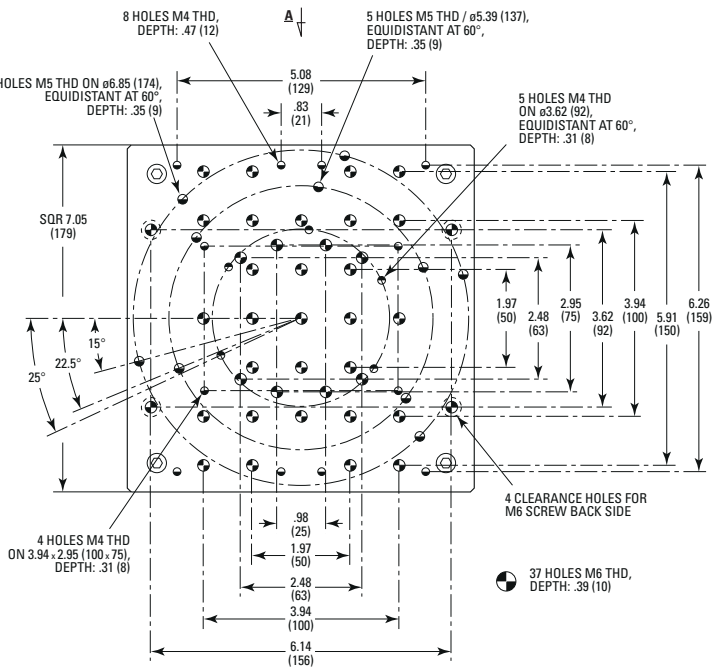

RECOMMENDED CONTROLLER/DRIVERS

XPS-Q2	2-axis Universal Controller/Driver, ethernet
XPS-DRV02	PWM drive module for brushless motors, 5 A/44 Vpp max.
XPS-EDBL	High-power, 3-phase, sinusoidal DC brushless motor driver
XPS-Q4	4-axis Universal Controller/Driver, ethernet
XPS-Q6	6-axis Universal Controller/Driver, ethernet
XPS-RL2	2-axis Universal Controller/Driver, ethernet, Basic GPIO and PCO
XPS-Q8	8-axis Universal Controller/Driver, ethernet

ORDERING INFORMATION

Model	Series	Travel (mm)	Drive	4-Point Mounting
M-	IMS	300 400 500 600 800 1000 1200	LM	-SA ⁽¹⁾

*Example:
The M-IMS800LM-SA is a metric version of IMS stage with 800 mm travel, a linear motor drive and 4-point mounting.*

¹⁾ 800, 1000 and 1200 mm travels available.

M-: For metric version

LM: Linear motor

SA: 4-point mounting

ACCESSORY: CABLE CHAINS

IMSLMC Cable chains for stages with a travel of 300 to 600 mm

IMSLMC2 Cable chains for stages with a travel of 800 to 1200 mm

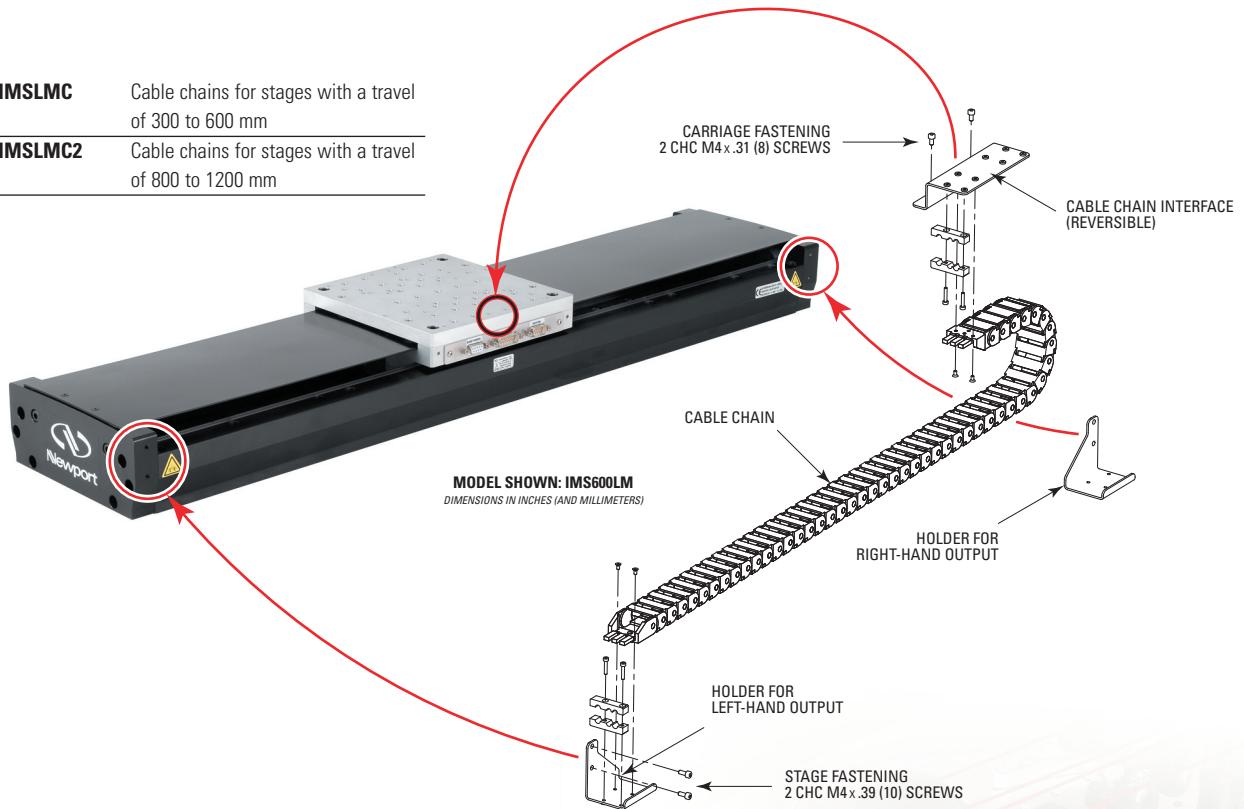

Newport Corporation, Global Headquarters
1791 Deere Avenue, Irvine, CA 92606, USA

PHONE: 1-800-222-6440 1-949-863-3144 FAX: 1-949-253-1680 EMAIL: sales@newport.com

Complete listings for all global office locations are available online at www.newport.com/contact

www.newport.com