

AirLift115

Air-Bearing Vertical Translation Stage

Unique Z stage design incorporates fully pre-loaded air bearings

$\leq \pm 2$ arc sec roll, pitch, and yaw over full travel

Submicron closed-loop positioning

Travel options from 50 to 150 mm

Precision-ground ball-screw-drive eliminates the need for special counterbalance

Aerotech's AirLift115 series stages offer the ideal solution for applications that require very stringent Z direction positioning while maintaining extremely tight angular performance over full travel. Applications include semiconductor wafer inspection and testing, noncontact metrology, optical inspection systems, and laser processing applications.

Unique Design

Aerotech's AirLift115 was designed to address the most significant limitation of conventional wedge-style vertical lift stages – angular performance. Although wedge-style Z stages provide a compact below-the-work-plane solution, they typically have limited pitch and roll stiffness that limits their angular performance. The AirLift 115's unique air-bearing design provides superior angular performance over larger travels while utilizing an innovative drive mechanism that eliminates the need for counterbalance mechanisms.



The AirLift115 directly addresses applications where:

- Tight angular performance is required over travel ranges that are too large for traditional wedge style Z stages (e.g., 50 mm)
- An unobstructed view of the work plane is desired
- Footprint must be kept to a minimum
- A failsafe brake is required

Motors and Drives

Included with the AirLift115 series stages are Aerotech's BMS series brushless rotary motors. This motor has all of the advantages of a brushless motor – high acceleration, no brushes to wear, and lower heating – yet has zero cogging for extremely smooth motion and accuracy. Aerotech manufactures a wide range of matching drives and controls to provide a fully integrated and optimized motion solution.

AirLift115 Series SPECIFICATIONS and DIMENSIONS

Mechanical Specifications		AirLift115-050	AirLift115-100	AirLift115-150
Travel		50 mm	100 mm	150 mm
Accuracy ⁽¹⁾	Standard	±2.0 µm	±4.0 µm	±6.0 µm
	Calibrated	±1.0 µm	±1.25 µm	±1.5 µm
Resolution (Minimum Incremental Motion)		0.05 µm		
Repeatability (Bidirectional) ⁽¹⁾		±0.5 µm		
Straightness ⁽²⁾		±0.25 µm	±0.35 µm	±0.45 µm
Pitch ⁽²⁾		±1 arc sec	±1.25 arc sec	±2 arc sec
Roll ⁽²⁾		±1 arc sec	±1.25 arc sec	±2 arc sec
Yaw ⁽²⁾		±1 arc sec	±1.25 arc sec	±2 arc sec
Maximum Speed	5 mm/rev	50 mm/s		
Maximum Acceleration		0.25 g		
Load Capacity ⁽³⁾	Vertical	15 kg		
Operating Pressure		80 psi		
Air Consumption		≤40 SLPM		
Material		Aluminum		
MTBF (Mean Time Between Failure)		15,000 Hours		

Notes:

1. Certified with each stage.
2. Specifications are for centered load. Other loading configurations will affect specifications.
3. Axis orientation for on-axis loading is listed.
4. Specifications are for single-axis systems measured 25 mm above the tabletop. Performance of multi-axis systems is payload and workpoint dependent. Consult factory for multi-axis or non-standard applications.
5. To protect air bearing against under-pressure condition, an in-line pressure switch tied to the motion controller is required.
6. Air supply must be clean, dry to 0°F dew point, and filtered to 0.25 µm or better.

Electrical Specifications	
Drive System	Brushless Rotary Servomotor
Feedback	Noncontact Linear Encoder
Maximum Bus Voltage	up to 160 VDC
Limit Switches	5 V, Normally Closed

Recommended Controller		
Multi-Axis	A3200	Ndrive MP/Ndrive CP/Ndrive HLe/Npaq MXR
	Ensemble	Ensemble MP/Ensemble CP/Ensemble HLe/Epaq
Single Axis	Soloist	Soloist MP/Soloist CP/Soloist HLe

Notes:

1. Linear amplifiers are required to achieve the listed specifications. Other options are available.

AirLift115 Series PERFORMANCE

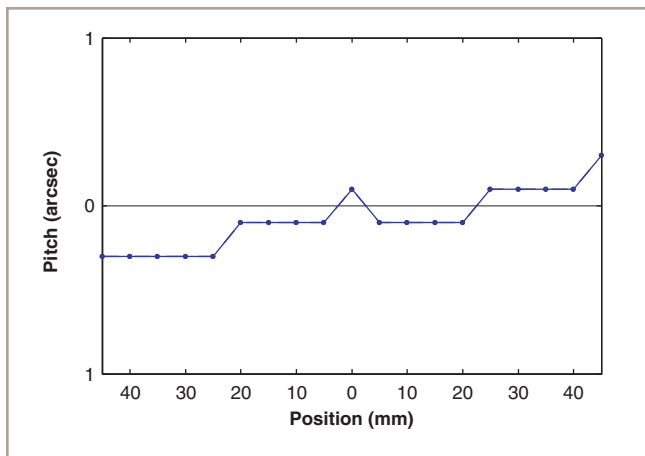

AirLift 115-100 pitch, one run, unidirectional.

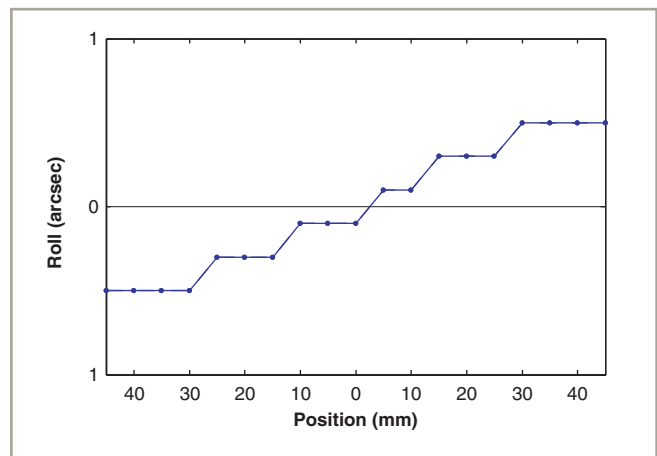

AirLift 115-100 roll, one run, unidirectional.

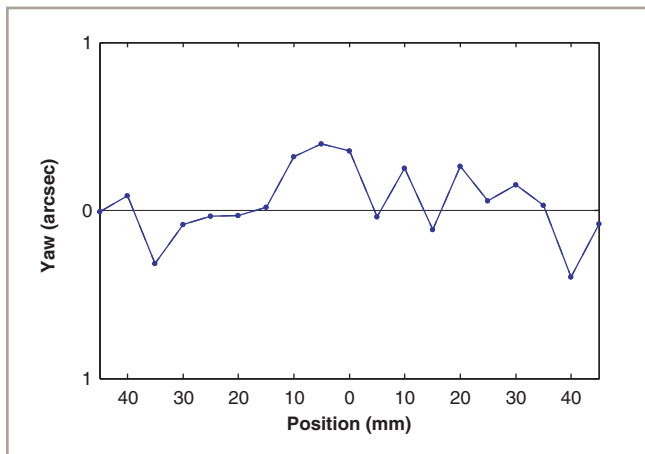

AirLift 115-100 yaw, one run, unidirectional.

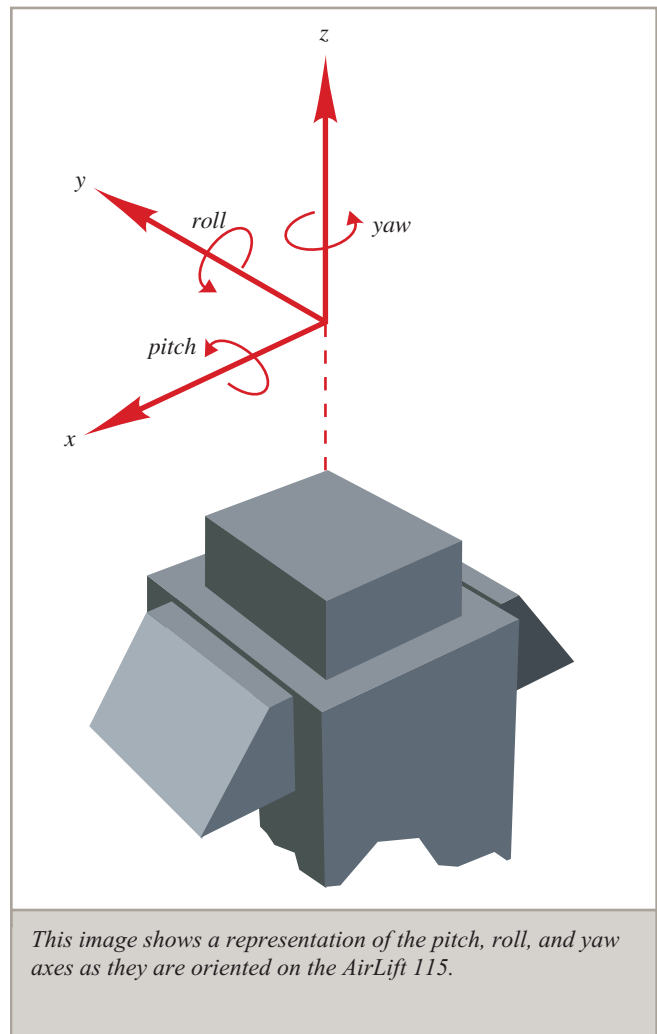

AirLift15 MT1 DIMENSIONS

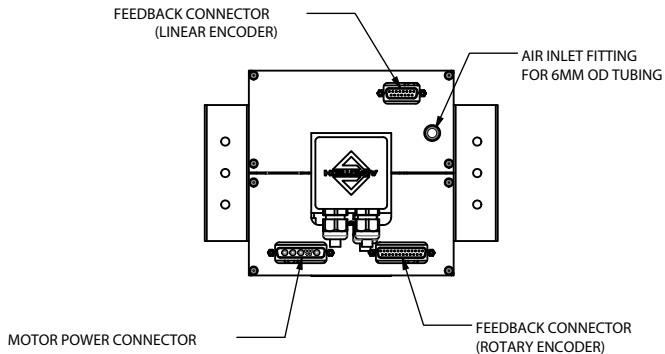
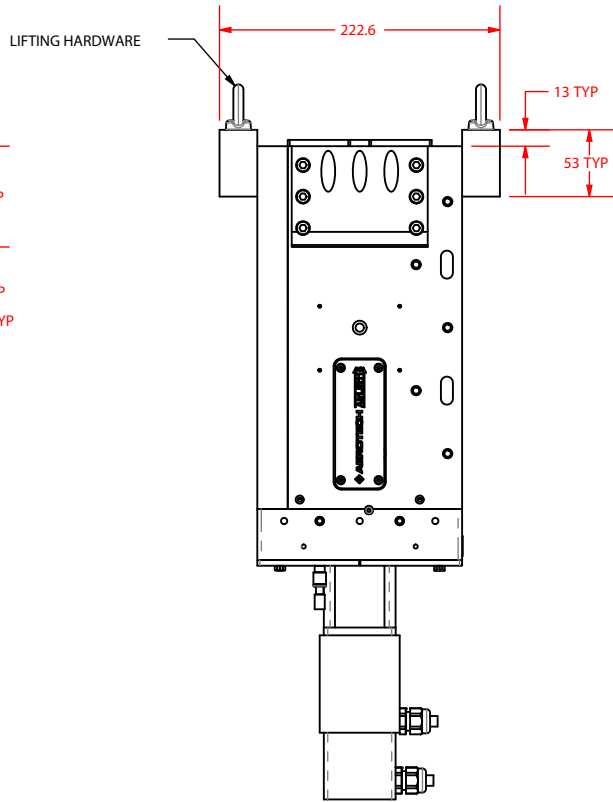
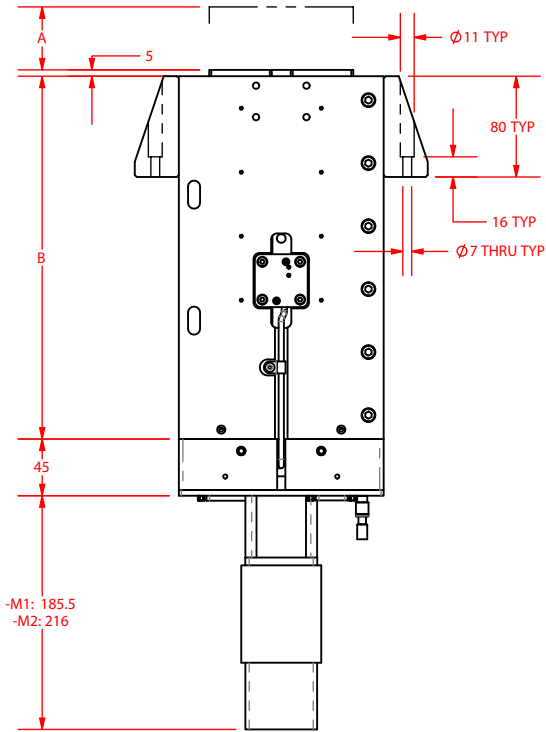
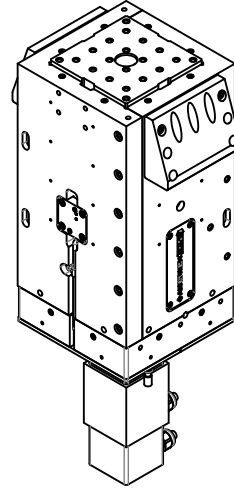
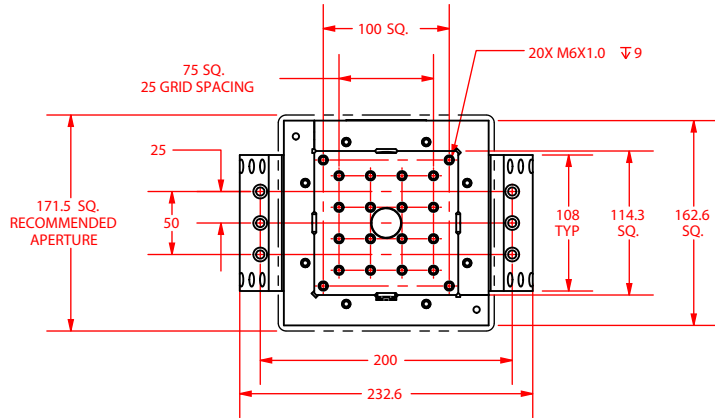

BASIC MODEL	A (TRAVEL)	B
AIRLIFT115-050	50	288
AIRLIFT115-100	100	338
AIRLIFT115-150	150	388

DIMENSIONS: MILLIMETERS

AirLift115 MT2 DIMENSIONS

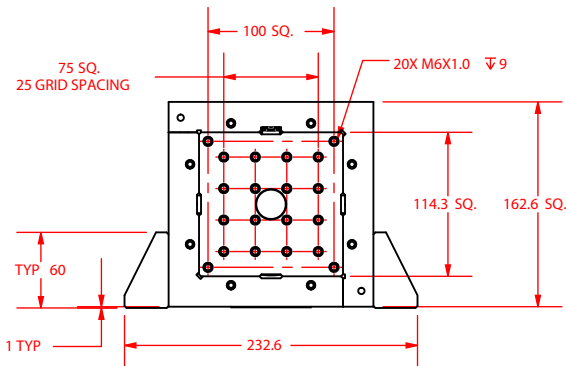
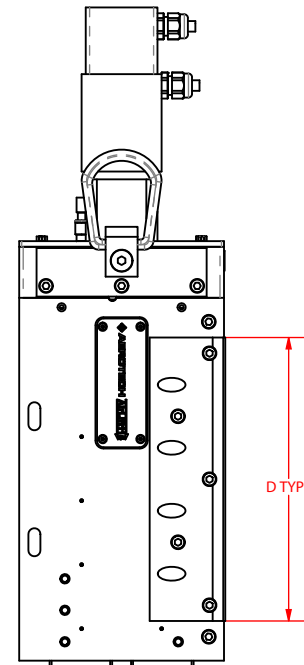
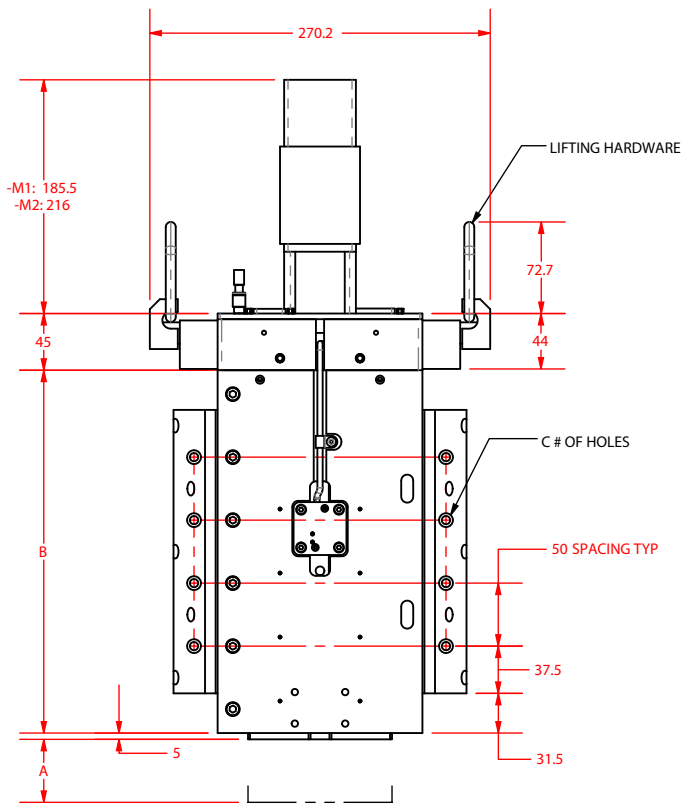
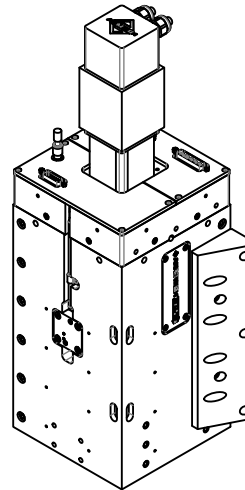
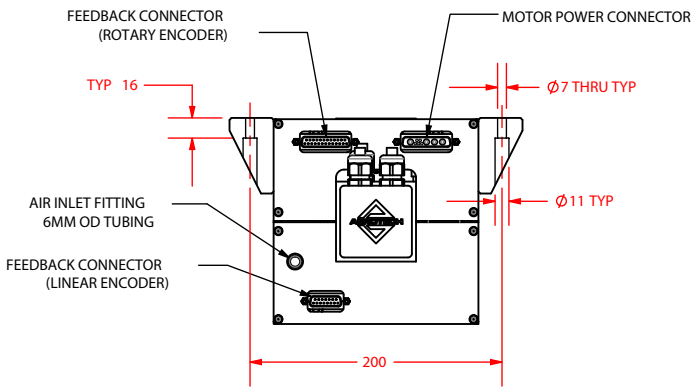

BASIC MODEL	A (TRAVEL)	B	C	D
AIRLIFT115-050	50	288	8	225
AIRLIFT115-100	100	338	10	275
AIRLIFT115-150	150	388	12	325

DIMENSIONS: MILLIMETERS

AirLift115 Series ORDERING INFORMATION

AirLift115 Air-Bearing Vertical Translation Stage

Travel

-050	50 mm travel
-100	100 mm travel
-150	150 mm travel

Motor

-M1	BMS60 brushless servomotor with connectors and brake
-M2	BMS100 brushless servomotor with connectors and brake

Motor Orientation

-MT1	Mounting orientation surface perpendicular to axis motion
-MT2	Mounting orientation surface parallel to axis motion

Metrology

-PL1	Metrology, uncalibrated with performance plots
-PL2	Metrology, calibrated (HALAR) with performance plots

Integration (Required)

Aerotech offers both standard and custom integration services to help you get your system fully operational as quickly as possible. The following standard integration options are available for this system. Please consult Aerotech if you are unsure what level of integration is required, or if you desire custom integration support with your system.

-TAS	Integration - Test as system Testing, integration, and documentation of a group of components as a complete system that will be used together (ex: drive, controller, and stage). This includes parameter file generation, system tuning, and documentation of the system configuration.
-TAC	Integration - Test as components Testing and integration of individual items as discrete components. This is typically used for spare parts, replacement parts, or items that will not be used or shipped together (ex: stage only). These components may or may not be part of a larger system.