

ANT95LZ Series

Single-Axis Z Direct-Drive Nanopositioning Stages

Nanometer performance in a large travel format (25 and 50 mm)

High resolution (2 nm), repeatability (75 nm), and accuracy (300 nm)

In-position stability of <2 nm

Anti-creep crossed-roller bearings

High dynamic performance

nano Motion Technology



Introduction

Aerotech's ANT series stages are the world's first nanometer-level positioning systems with greater than 25 mm travel. The ANT95LZ crossed-roller stages are the best-in-class in combining speed, accuracy, resolution, repeatability, reliability, and size, and are offered in two accuracy grades.

Noncontact Direct-Drive

Only noncontact direct-drive technology offers the robust, accurate, and high-speed positioning necessary for mass production of precision devices. ANT95LZ stages utilize advanced direct-drive technology pioneered by Aerotech to achieve the highest level of positioning performance for high-precision positioning, disk-drive fabrication, fiber alignment, optical delay element actuation, sensor testing, and scanning processes that demand smooth and precise motion.

The ANT95LZ stages use a nearly frictionless counterbalance mechanism to maintain performance levels while minimizing motor heating. The counterbalance is user-adjustable from 0 to 5 kg.

Flexible System Design

The ANT95LZ family has universal mounting and tabletop patterns that allow for easy system integration. Two, three, or more axes can be easily combined for flexible system designs and multi-axis configurations.

System Characteristics

Outstanding accuracy, position repeatability, and in-position stability require high system resolution. The ANT95LZ stage's industry-leading 2 nm minimum incremental step size provides this high level of performance. Excellent in-position stability is assisted by high-quality, anti-creep, crossed-roller bearings. The stage offers virtually maintenance-free operation over the life of the product. Aerotech's direct-drive technology has no hysteresis or backlash, enabling accurate and repeatable nanometer-scale motion.

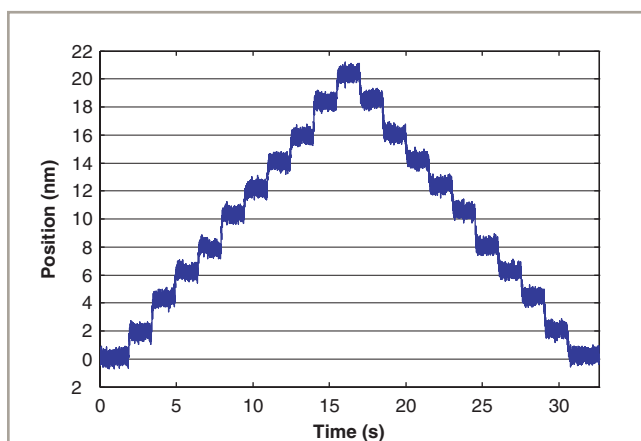

ANT95LZ-050-PLUS 2 nm step plot with 100 Hz filter. Best-in-class resolution and exceptional in-position stability for large travel stages.

ANT95LZ Series SPECIFICATIONS

		ANT95-25-L-Z	ANT95-50-L-Z
Travel		25 mm (1 in)	50 mm (2 in)
Accuracy⁽¹⁾	Basic	±4.0 µm (±160 µin)	±4.0 µm (±160 µin)
	PLUS	±300 nm (±12 µin)	±300 nm (±12 µin)
Resolution (Minimum Incremental Motion)		2 nm	2 nm
Repeatability (Bi-Directional)⁽¹⁾	Basic	±100 nm	±100 nm
	PLUS	±75 nm	±75 nm
Repeatability (Uni-Directional)		±50 nm	±50 nm
Straightness⁽¹⁾		±2.25 µm (±90 µin)	±3.0 µm (±120 µin)
Flatness⁽¹⁾		±3.5 µm (±140 µin)	±4.0 µm (±160 µin)
Pitch		10 arc sec	10 arc sec
Roll		10 arc sec	10 arc sec
Yaw		5 arc sec	5 arc sec
Maximum Speed		200 mm/s (8 in/s)	200 mm/s (8 in/s)
Maximum Acceleration		1 g - 10 m/s ² (No Load)	1 g - 10 m/s ² (No Load)
In-Position Stability⁽²⁾		<2 nm (<0.08 µin)	<2 nm (<0.08 µin)
Maximum Force (Continuous)		7.75 N	9.5 N
Load Capacity⁽³⁾	Vertical	5.0 kg (11 lb)	5.0 kg (11 lb)
Moving Mass		0.46 kg (1.0 lb)	0.52 kg (1.1 lb)
Stage Mass		1.9 kg (4.3 lb)	2.5 kg (5.5 lb)
Material		Aluminum Body/Black Hardcoat Finish	
MTBF (Mean Time Between Failure)		30,000 Hours	

Notes:

- Certified with each stage.
- In-Position Jitter listing is 3σ value.
- Axis orientation for on-axis loading is listed.
- Specifications are for single-axis systems measured 25 mm above the tabletop. Performance of multi-axis systems is payload and workpoint dependent. Consult factory for multi-axis or non-standard applications.
- PLUS requires the use of an Aerotech controller.

Electrical Specifications	ANT95LZ
Drive System	Brushless Linear Servomotor
Feedback	Noncontact Linear Encoder
Maximum Bus Voltage	±40 VDC
Limit Switches	5 V, Normally Closed
Home Switch	Near Center

Recommended Controller	ANT95LZ
Multi-Axis	A3200 Npaq-MXR Npaq MR-MXH Ndrive ML-MXH
	Ensemble Epaq-MXH Epaq MR-MXH Ensemble ML-MXH
Single Axis	Soloist Soloist ML-MXH

Notes:

- Linear amplifiers are required to achieve the listed specifications. Other options are available.

Note: To ensure the achievement and repeatability of specifications over an extended period of time, environmental temperature must be controlled to within 0.25°C/24 hours. If this is not possible, alternate products are available. Please consult Aerotech Application Engineering for more information.

ANT95LZ Series PERFORMANCE

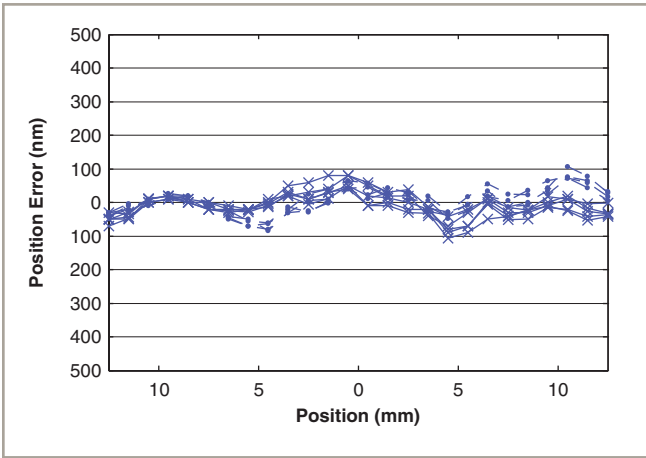

ANT95LZ-025-PLUS accuracy and repeatability. This multiple test run over an extended period of time shows the high level of system accuracy and repeatability.

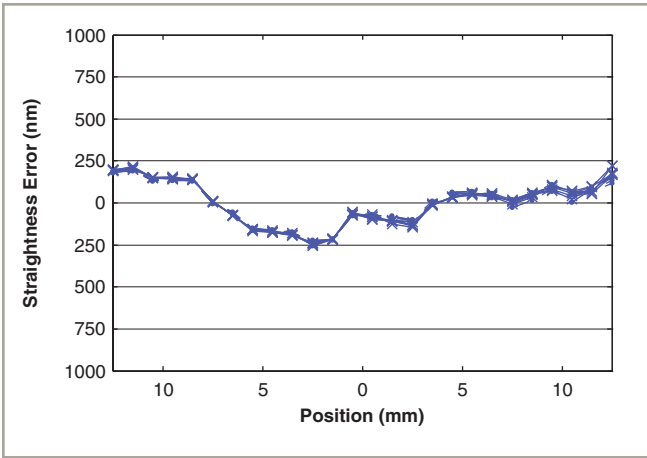

ANT95LZ-025-PLUS straightness error, five runs, bi-directional. Exceptional and highly repeatable – five times more accurate than the stated specification.

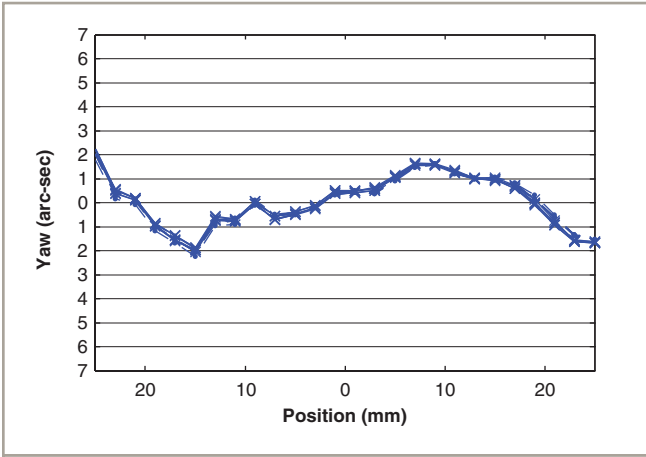

ANT95LZ-050-PLUS yaw, five runs, bi-directional. Highly repeatable, minimal yaw error enhances system positioning accuracy.

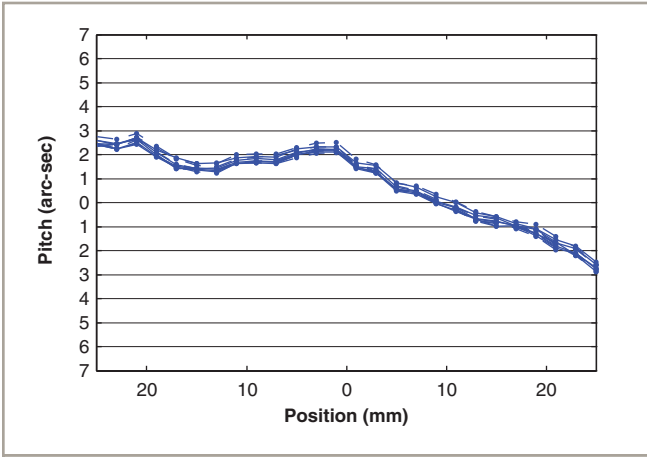

ANT95LZ-050-PLUS pitch, five runs, bi-directional. Excellent repeatability/accuracy contribute to improved processing.

ANT95LZ-025 DIMENSIONS

ANT95LZ-025

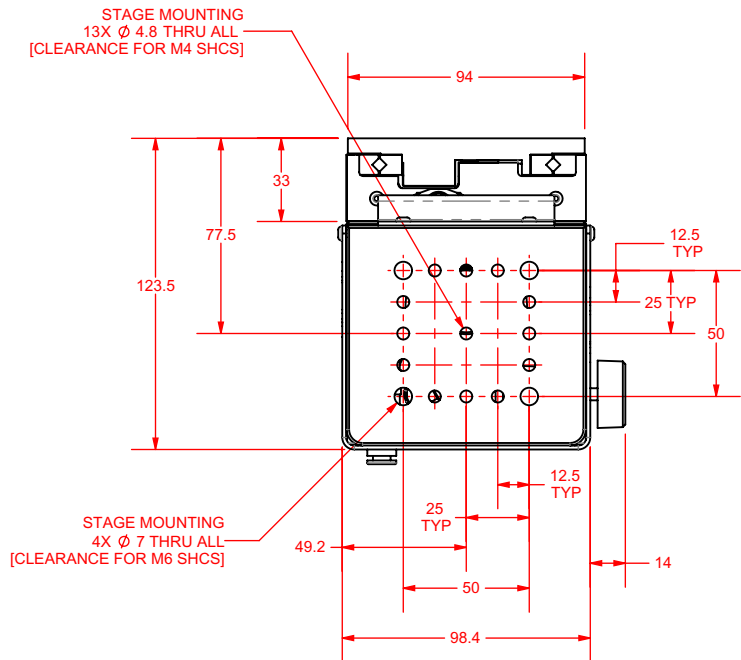
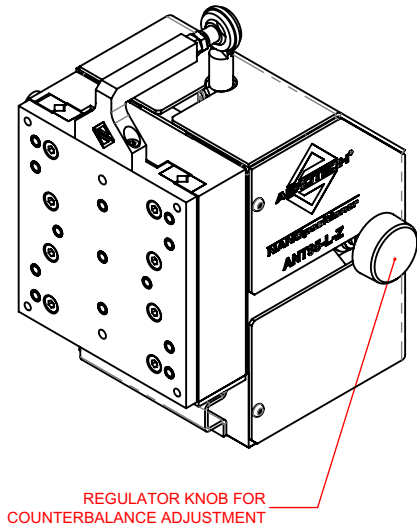
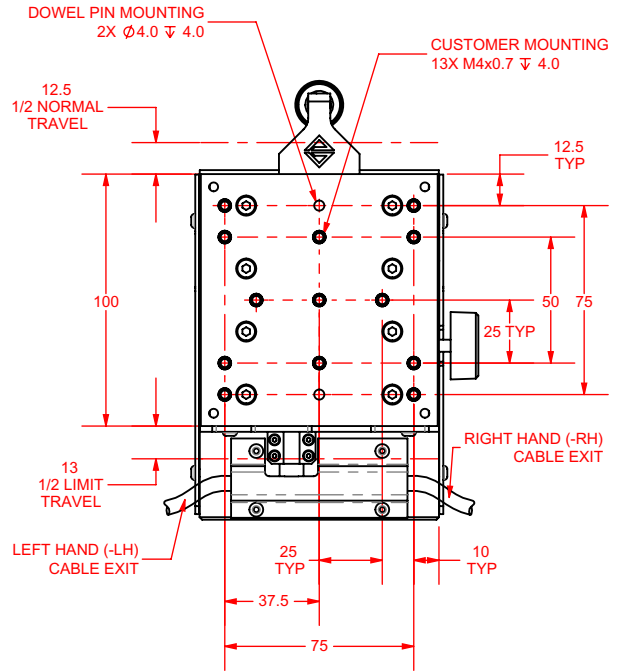
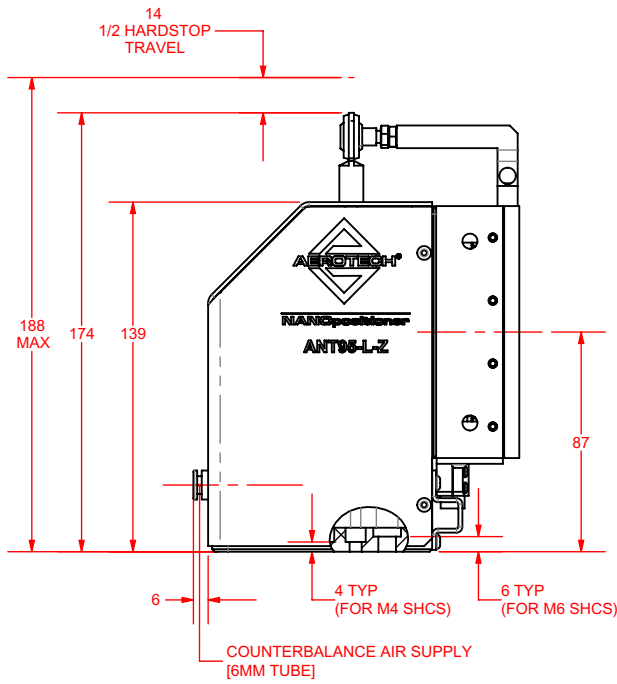

DIMENSIONS: MILLIMETERS

ANT95LZ-050 DIMENSIONS

ANT95LZ-050

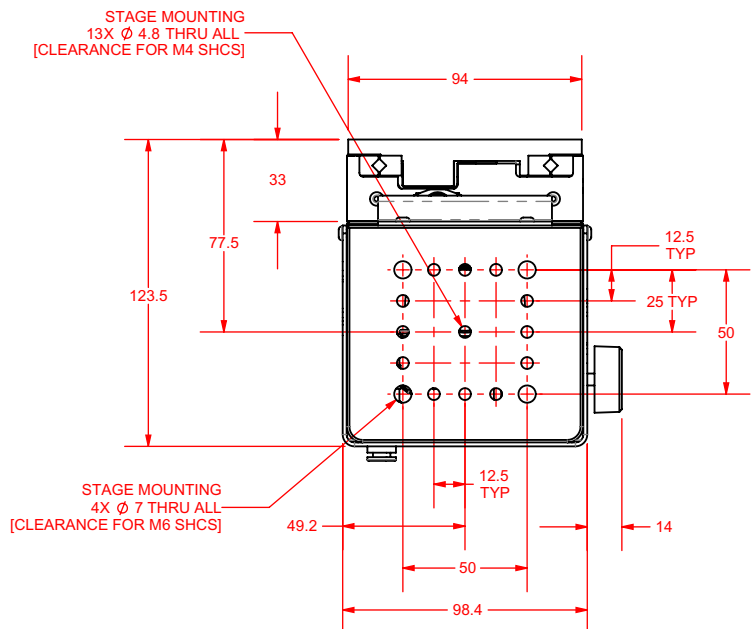
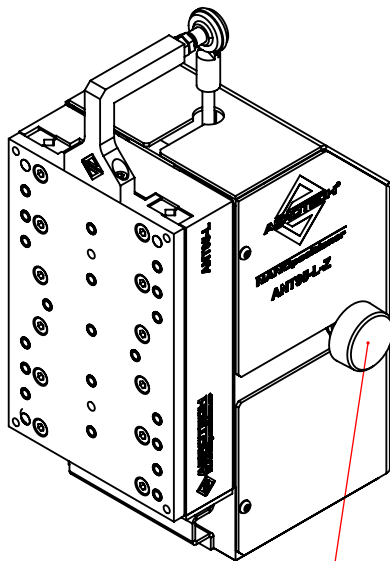
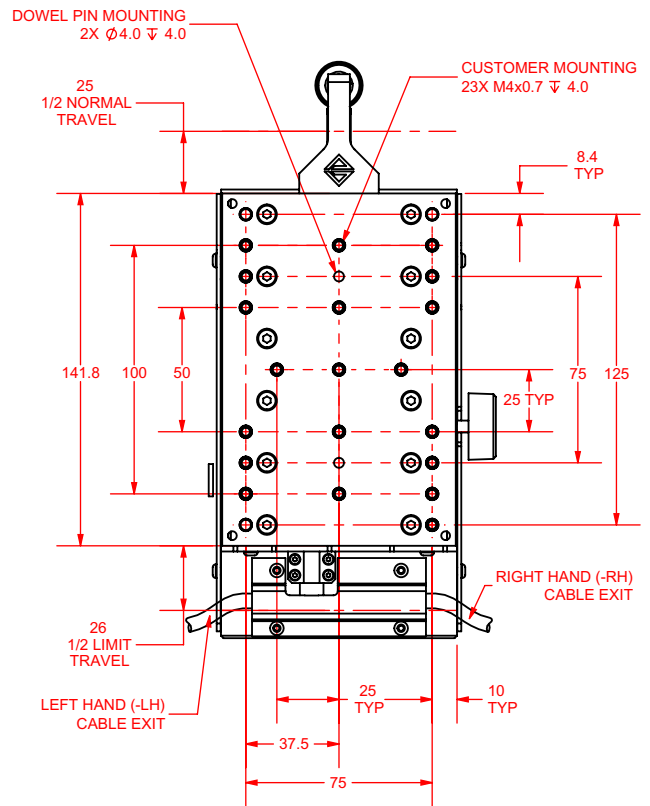
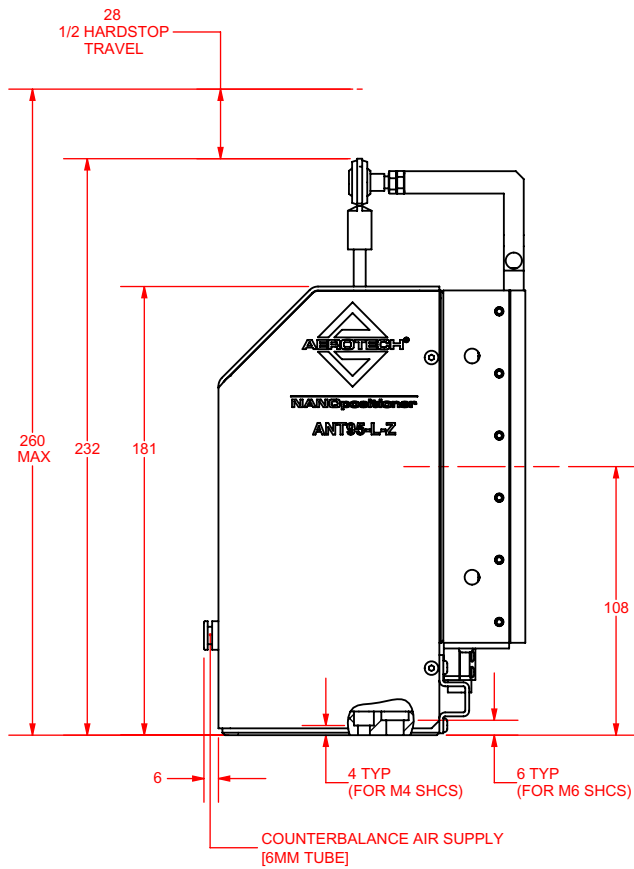

DIMENSIONS: MILLIMETERS

ANT95LZ Series ORDERING INFORMATION

Travel (Required)

-025	25 mm travel
-050	50 mm travel

Cable Orientation (Required)

-CBL1	Right-hand cable exit
-CBL2	Left-hand cable exit

Performance Grade (Required)

-PL1	Base performance
-PL2	High-accuracy performance, PLUS

Integration (Required)

Aerotech offers both standard and custom integration services to help you get your system fully operational as quickly as possible. The following standard integration options are available for this system. Please consult Aerotech if you are unsure what level of integration is required, or if you desire custom integration support with your system.

-TAS	<p>Integration - Test as system</p> <p>Testing, integration, and documentation of a group of components as a complete system that will be used together (ex: drive, controller, and stage). This includes parameter file generation, system tuning, and documentation of the system configuration.</p>
-TAC	<p>Integration - Test as components</p> <p>Testing and integration of individual items as discrete components. This is typically used for spare parts, replacement parts, or items that will not be used or shipped together (ex: stage only). These components may or may not be part of a larger system.</p>