

# ANT130XY Series

## Two-Axis XY Direct-Drive Nanopositioning Stages

- Integrated low-profile XY linear motor stage
- Nanometer-level performance in a large travel format
- High resolution (1 nm), repeatability (75 nm), and accuracy (250 nm)
- In-position stability of <1 nm
- Anti-creep crossed-roller bearings
- High dynamic performance with direct-drive technology
- ULTRA performance grade option

## nano Motion Technology



### Introduction

The ANT130XY series stages offer nanometer-level performance in XY travels up to 160 mm. The integrated, sleek design provides an extremely low profile of only 85 mm. The stage comes with proprietary direct-drive motor technology, noncontact linear encoders, limits, integrated cable management system, and three performance grades.

### Ultra-Precise Stage Design

The ANT130XY design allows critical elements such as orthogonality, straightness, and flatness to be optimized, resulting in a stage with exceptional geometric tolerances. Aerotech's direct-drive technology has no hysteresis or backlash, enabling accurate and repeatable nanometer-scale motion in both the X and Y dimensions. All travel options (60 mm x 60 mm, 110 mm x 110 mm, 160 mm x 160 mm) come with the 85 mm profile height. The integrated cable management system is designed for long life and to minimize drag forces.

### Noncontact Direct-Drive

Only noncontact direct-drive technology offers the robust, accurate, and high-speed positioning necessary for mass production of precision devices. ANT130XY stages utilize advanced direct-drive technology pioneered by Aerotech to achieve the highest level of positioning performance. This direct-drive technology is high-performance, non-cogging, noncontact, high speed, high resolution, and high accuracy. This unique drive and bearing combination, packaged in an extremely small-profile and footprint, offers tangible advantages in many applications such as high-precision

positioning, disk-drive fabrication, fiber alignment, optical delay element actuation, sensor testing, and scanning processes that demand smooth and precise motion.

### Multi-Axis Configurations

The ANT130XY can be combined with other Aerotech ANT series products (vertical lift stages, direct-drive rotaries, and goniometers) to create unique, high performance, multi-axis systems.

### ULTRA Performance Grade Option

In order to achieve the highest possible system accuracy from our multi-axis nanopositioning systems, Aerotech has developed an advanced, dynamic trajectory calibration system. To take advantage of this sophisticated calibration system, the mechanical system has to be completely assembled, functionally tested, and calibrated in our best-in-class metrology labs. Nanometer-level system accuracy can only be achieved under stringent environmental conditions, calibrating with the best test equipment, using the highest-precision mechanical elements, and utilizing the ULTRA software capabilities of Aerotech's industry-leading controls. By implementing ULTRA dynamic trajectory calibration with the ANT130XY, we are able to produce guaranteed two-dimensional accuracies of  $\pm 250$  nm or better.

The plots provided in the specifications illustrate performance differences between a standard ANT130XY and the ULTRA version. Straightness errors, orthogonality errors, and accuracy errors caused by stage yawing are virtually eliminated.

Mechanical Specifications	ANT130XY-060		
	Base	PLUS <sup>(1,2)</sup>	ULTRA <sup>(1,2)</sup>
Travel	60 mm		
Accuracy <sup>(2,3)</sup>	±2.5 µm	±250 nm	±250 nm
Resolution (Minimum Incremental Motion)	1 nm		
Repeatability (Bidirectional) <sup>(3)</sup>	±100 nm	±75 nm	±75 nm
Repeatability (Unidirectional)	±25 nm	±25 nm	±25 nm
Straightness <sup>(3)</sup>	±1.5 µm	±1.5 µm	±250 nm
Flatness <sup>(3)</sup>	±1.5 µm	±1.5 µm	±1.0 µm
Pitch	49 µrad (10 arc sec)	49 µrad (10 arc sec)	49 µrad (10 arc sec)
Roll	49 µrad (10 arc sec)	49 µrad (10 arc sec)	49 µrad (10 arc sec)
Yaw	24 µrad (5 arc sec)	24 µrad (5 arc sec)	24 µrad (5 arc sec)
Orthogonality	49 µrad (10 arc sec)	15 µrad (3 arc sec)	4.8 µrad (1 arc sec)
Maximum Speed <sup>(4)</sup>	350 mm/s (Upper Axis)		
Maximum Acceleration <sup>(4)</sup>	1 g - 10 m/s <sup>2</sup> (No Load) (Upper Axis)		
Speed Stability	See graph for typical performance		
Settling Time	See graph for typical performance		
In-Position Stability <sup>(5)</sup>	<1 nm		
Maximum Force (Continuous)	23 N		
Load Capacity <sup>(6)</sup>	Horizontal	12.0 kg	
	Upper	1.5 kg	
Moving Mass	Upper	1.5 kg	
	Lower	4.2 kg	
Stage Mass	5.5 kg		
Material	Aluminum Body/Black Hardcoat Finish		
MTBF (Mean Time Between Failure)	30,000 Hours		

Notes:

1. -PLUS and -ULTRA require the use of an Aerotech controller.
2. Specifications for -BASE and -PLUS options are per axis measured 25 mm above the tabletop. Specifications for -ULTRA are XY measured 25 mm above the tabletop.
3. Certified with each stage.
4. Requires the selection of an appropriate amplifier with sufficient voltage and current.
5. In-position jitter listing is 3 sigma value.
6. Axis orientation for on-axis loading is listed.

Mechanical Specifications	ANT130XY-110		
	Base	PLUS <sup>(1,2)</sup>	ULTRA <sup>(1,2)</sup>
Travel	110 mm		
Accuracy <sup>(2,3)</sup>	±4.0 µm	±300 nm	±300 nm
Resolution (Minimum Incremental Motion)	1 nm		
Repeatability (Bidirectional) <sup>(3)</sup>	±100 nm	±75 nm	±75 nm
Repeatability (Unidirectional)	±25 nm	±25 nm	±25 nm
Straightness <sup>(3)</sup>	±1.5 µm	±1.5 µm	±300 nm
Flatness <sup>(3)</sup>	±1.5 µm	±1.5 µm	±1.0 µm
Pitch	58 µrad (12 arc sec)	58 µrad (12 arc sec)	58 µrad (12 arc sec)
Roll	58 µrad (12 arc sec)	58 µrad (12 arc sec)	58 µrad (12 arc sec)
Yaw	29 µrad (6 arc sec)	29 µrad (6 arc sec)	29 µrad (6 arc sec)
Orthogonality	49 µrad (10 arc sec)	15 µrad (3 arc sec)	2.4 µrad (0.5 arc sec)
Maximum Speed <sup>(4)</sup>	350 mm/s (Upper Axis)		
Maximum Acceleration <sup>(4)</sup>	1 g - 10 m/s <sup>2</sup> (No Load) (Upper Axis)		
Speed Stability	See graph for typical performance		
Settling Time	See graph for typical performance		
In-Position Stability <sup>(5)</sup>	<1 nm		
Maximum Force (Continuous)	23 N		
Load Capacity <sup>(6)</sup>	Horizontal	12.0 kg	
	Upper	2.1 kg	
Moving Mass	Upper	2.1 kg	
	Lower	5.7 kg	
Stage Mass	7.4 kg		
Material	Aluminum Body/Black Hardcoat Finish		
MTBF (Mean Time Between Failure)	30,000 Hours		

Notes:

1. -PLUS and -ULTRA require the use of an Aerotech controller.
2. Specifications for -BASE and -PLUS options are per axis measured 25 mm above the tabletop. Specifications for -ULTRA are XY measured 25 mm above the tabletop.
3. Certified with each stage.
4. Requires the selection of an appropriate amplifier with sufficient voltage and current.
5. In-position jitter listing is 3 sigma value.
6. Axis orientation for on-axis loading is listed.

## ANT130XY Series SPECIFICATIONS

Mechanical Specifications	ANT130XY-160		
	Base	PLUS <sup>(1,2)</sup>	ULTRA <sup>(1,2)</sup>
Travel	160 mm		
Accuracy <sup>(2,3)</sup>	±5.0 µm	±300 nm	±300 nm
Resolution (Minimum Incremental Motion)	1 nm		
Repeatability (Bidirectional) <sup>(3)</sup>	±100 nm	±75 nm	±75 nm
Repeatability (Unidirectional)	±25 nm	±25 nm	±25 nm
Straightness <sup>(3)</sup>	±2.0 µm	±2.0 µm	±300 nm
Flatness <sup>(3)</sup>	±2.0 µm	±2.0 µm	±1.0 µm
Pitch	73 µrad (15 arc sec)	73 µrad (15 arc sec)	58 µrad (12 arc sec)
Roll	73 µrad (15 arc sec)	73 µrad (15 arc sec)	58 µrad (12 arc sec)
Yaw	39 µrad (8 arc sec)	39 µrad (8 arc sec)	29 µrad (6 arc sec)
Orthogonality	49 µrad (10 arc sec)	15 µrad (3 arc sec)	2.4 µrad (0.5 arc sec)
Maximum Speed <sup>(4)</sup>	350 mm/s (Upper Axis)		
Maximum Acceleration <sup>(4)</sup>	1 g - 10 m/s <sup>2</sup> (No Load) (Upper Axis)		
Speed Stability	See graph for typical performance		
Settling Time	See graph for typical performance		
In-Position Stability <sup>(5)</sup>	<1 nm		
Maximum Force (Continuous)	23 N		
Load Capacity <sup>(6)</sup>	Horizontal	12.0 kg	
	Upper	2.4 kg	
Moving Mass	Lower	6.9 kg	
	Stage Mass	8.9 kg	
Material	Aluminum Body/Black Hardcoat Finish		
MTBF (Mean Time Between Failure)	30,000 Hours		

Notes:

1. -PLUS and -ULTRA require the use of an Aerotech controller.
2. Specifications for -BASE and -PLUS options are per axis measured 25 mm above the tabletop. Specifications for -ULTRA are XY measured 25 mm above the tabletop.
3. Certified with each stage.
4. Requires the selection of an appropriate amplifier with sufficient voltage and current.
5. In-position jitter listing is 3 sigma value.
6. Axis orientation for on-axis loading is listed.

Electrical Specifications	
Drive System	Brushless Linear Servomotor
Feedback	Noncontact Linear Encoder
Maximum Bus Voltage	320 VDC (-4DU-25DU), 80 VDC (-25DU)
Limit Switches	5 V, Normally Closed
Home Switch	Near Center

Recommended Controller		
Multi-Axis	A3200	Npaq MXR Npaq MR-MXH Ndrive ML-MXH
	Ensemble	Epaq MXH Epaq MR-MXH Ensemble ML-MXH Ensemble LAB
Single Axis	Soloist	Soloist ML-MXH

Note: Linear amplifiers are required to achieve the listed specifications. Other options are available.

Note: To ensure the achievement and repeatability of specifications over an extended period of time, environmental temperature must be controlled to within 0.25°C/24 hours. If this is not possible, alternate products are available. Please consult Aerotech Application Engineering for more information.

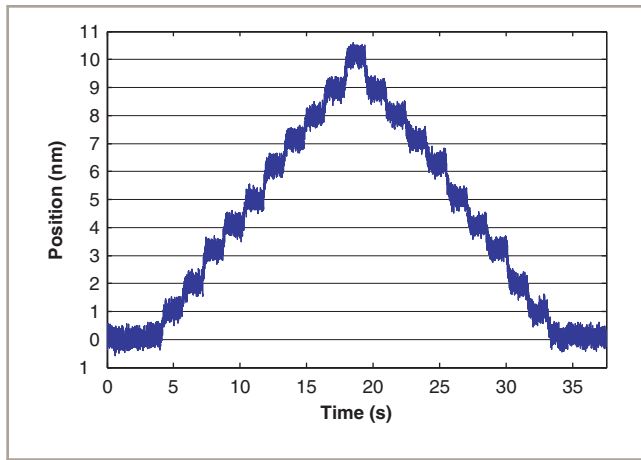

ANT130XY-160-PLUS lower axis 1 nm step plot with 100 Hz filter. Best-in-class resolution and exceptional in-position stability for large travel stages.

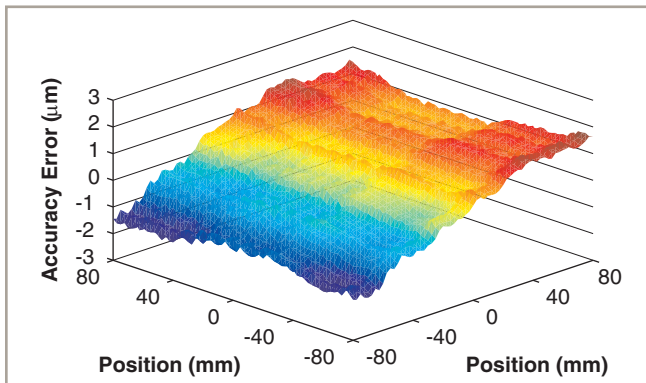

ANT130XY-160 2D accuracy plot showing planar accuracy error including straightness, orthogonality, and stage yawing.

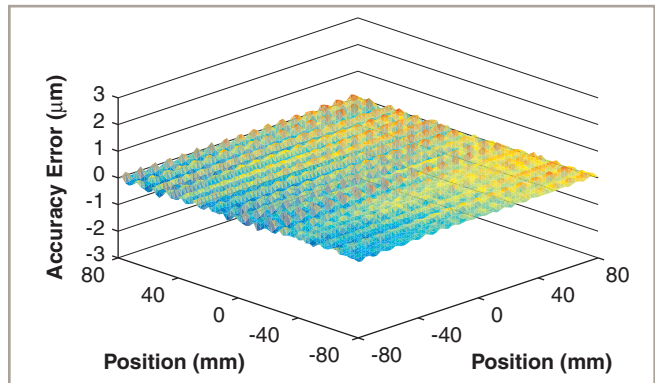

ANT130XY-160-ULTRA – exceptional 2D system accuracy with Aerotech’s ULTRA version.

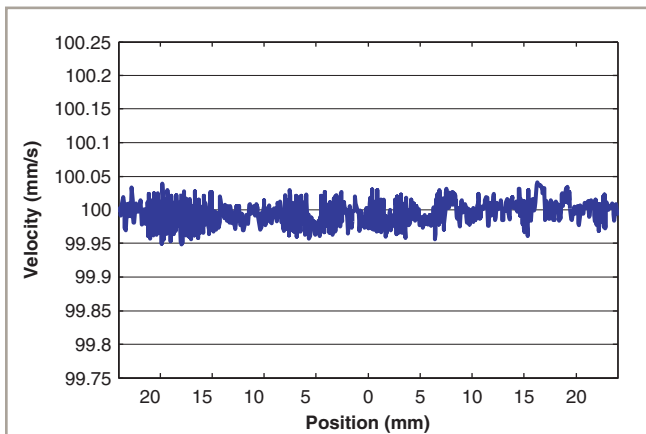

ANT130XY-060-PLUS velocity performance at 100 mm/s and 1 kg payload for the X (lower) axis. This outstanding speed stability enhances most scanning or laser machining applications.

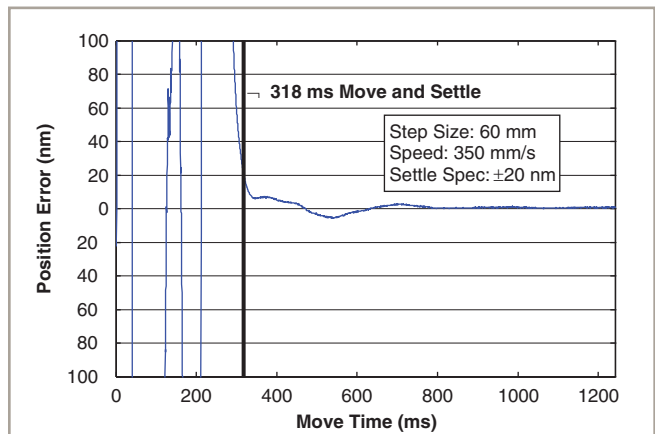

ANT130XY-060-PLUS step and settle performance at full travel and 1 kg payload for the X (lower) axis. Industry-best settling times significantly improve throughput for most applications.

## ANT130XY Series PERFORMANCE

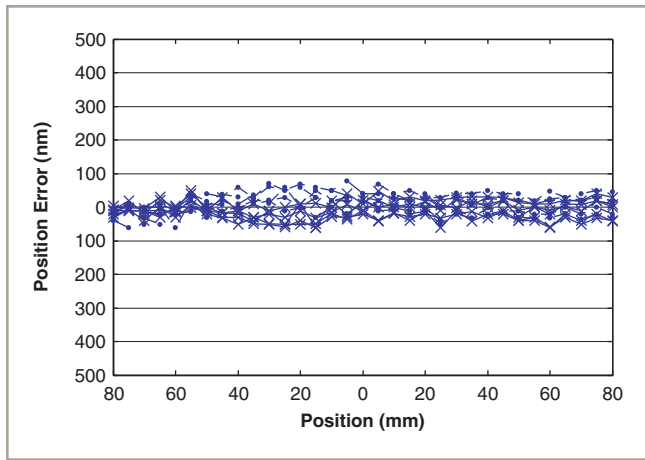

*ANT130XY-160-PLUS accuracy and repeatability, five runs, bi-directional for the Y (upper) axis. The total accuracy of  $\pm 75$  nm over 160 mm travel is significantly better than other offerings.*

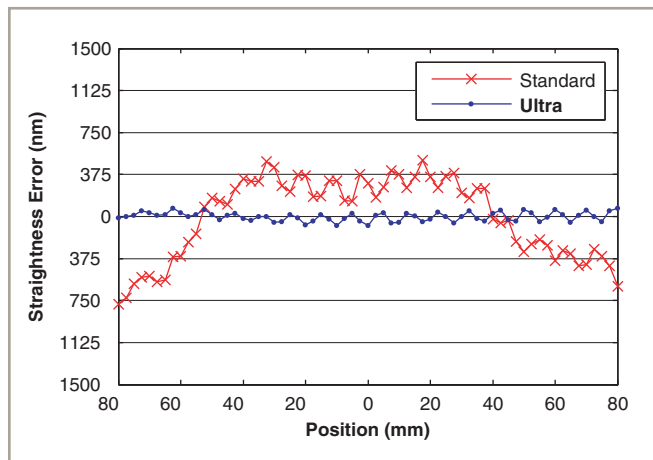

*ANT130XY-160 straightness error comparison between the BASE and ULTRA models shows a dramatic improvement in this specification.*

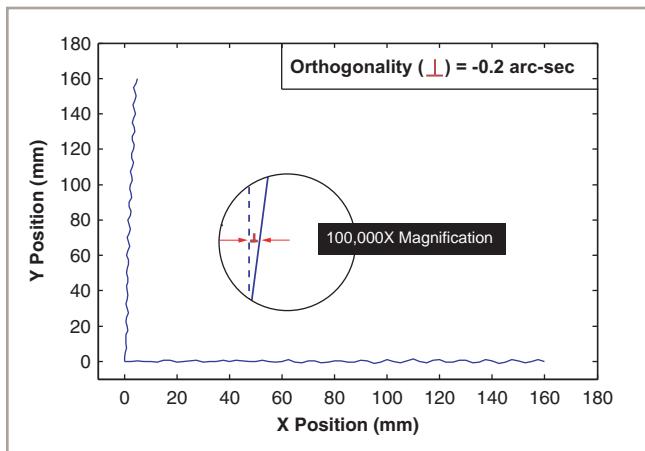

*ANT130XY-060-ULTRA orthogonality. The inset is magnified 100,000X for clarity. The ULTRA model orthogonality is a twenty-fold improvement over the BASE model orthogonality.*

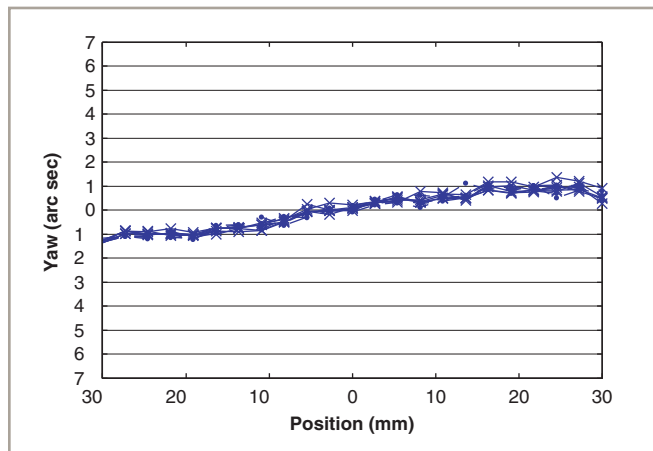

*ANT130XY-060-PLUS Y (upper) axis yaw, five runs, bi-directional. Highly repeatable, lowest angular error over full travel.*

# ANT130XY DIMENSIONS

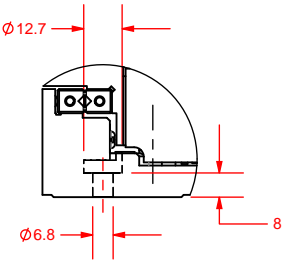
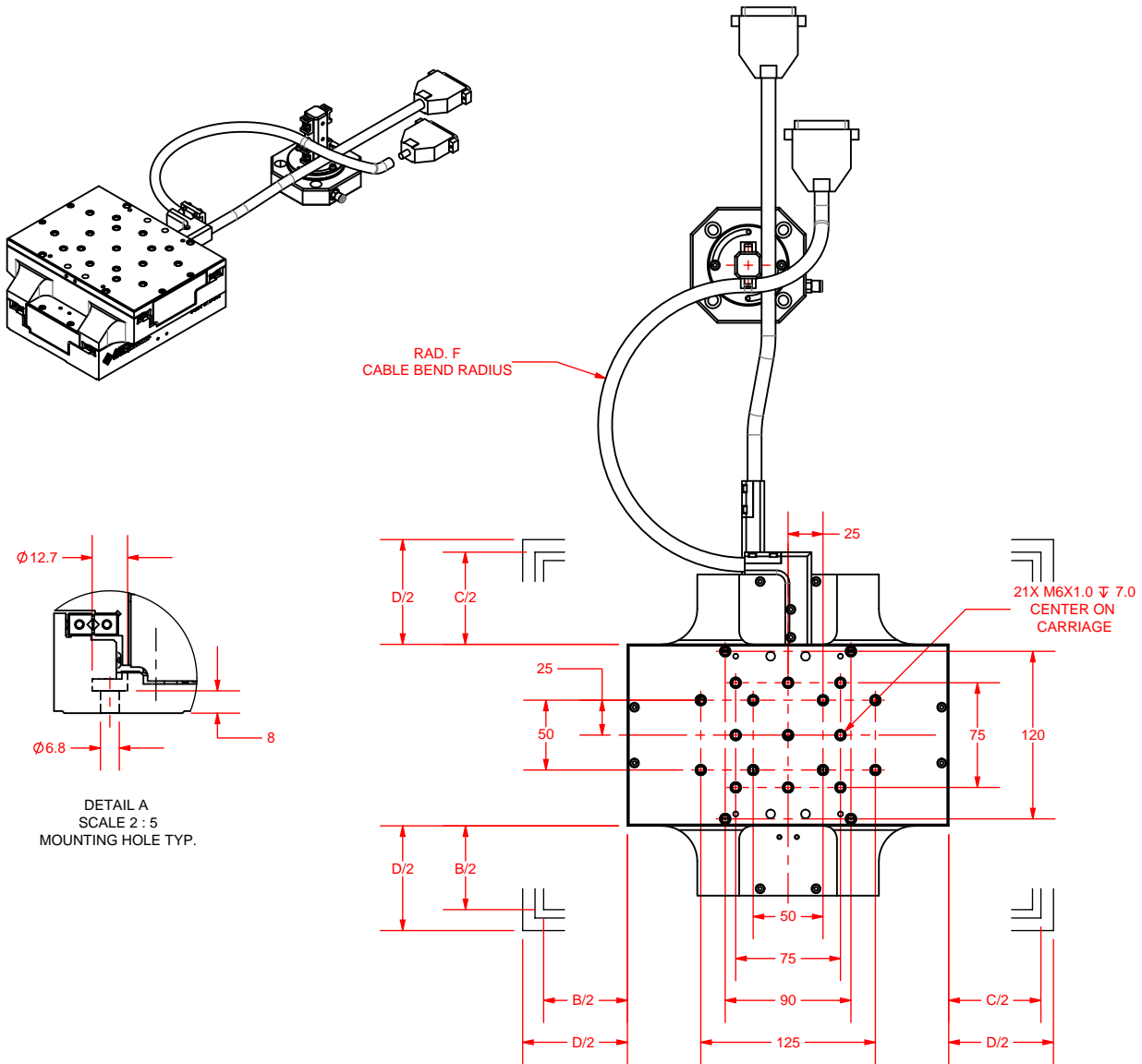

DETAIL A  
SCALE 2 : 5  
MOUNTING HOLE TYP.

TRAVEL OPTION	A = STAGE LENGTH	B = NOMINAL TRAVEL	C = LIMIT TRAVEL	D = HARDSTOP TRAVEL	E	F
-060	180	60 X 60	66 X 66	75 X 75	42	-87.5
-110	230	110 X 110	116 X 116	125 X 125	67	-100
-160	280	160 X 160	166 X 166	175 X 175	92	-112.5

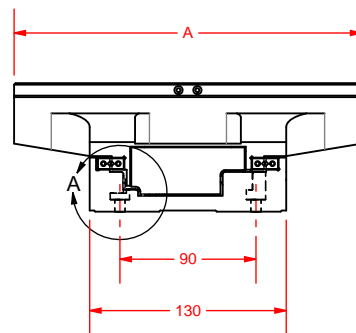
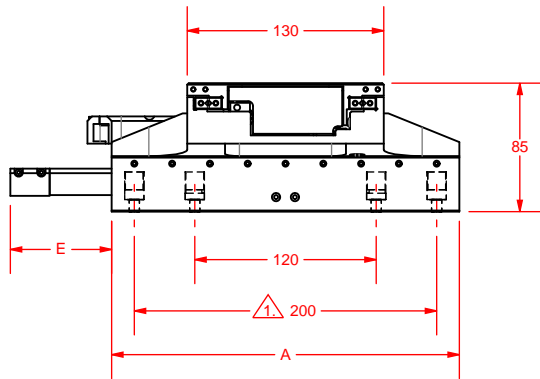

⚠ ANT130XY-110 AND ANT130XY-160 ONLY

DIMENSIONS: MILLIMETERS

# ANT130XY Mounting Plate DIMENSIONS

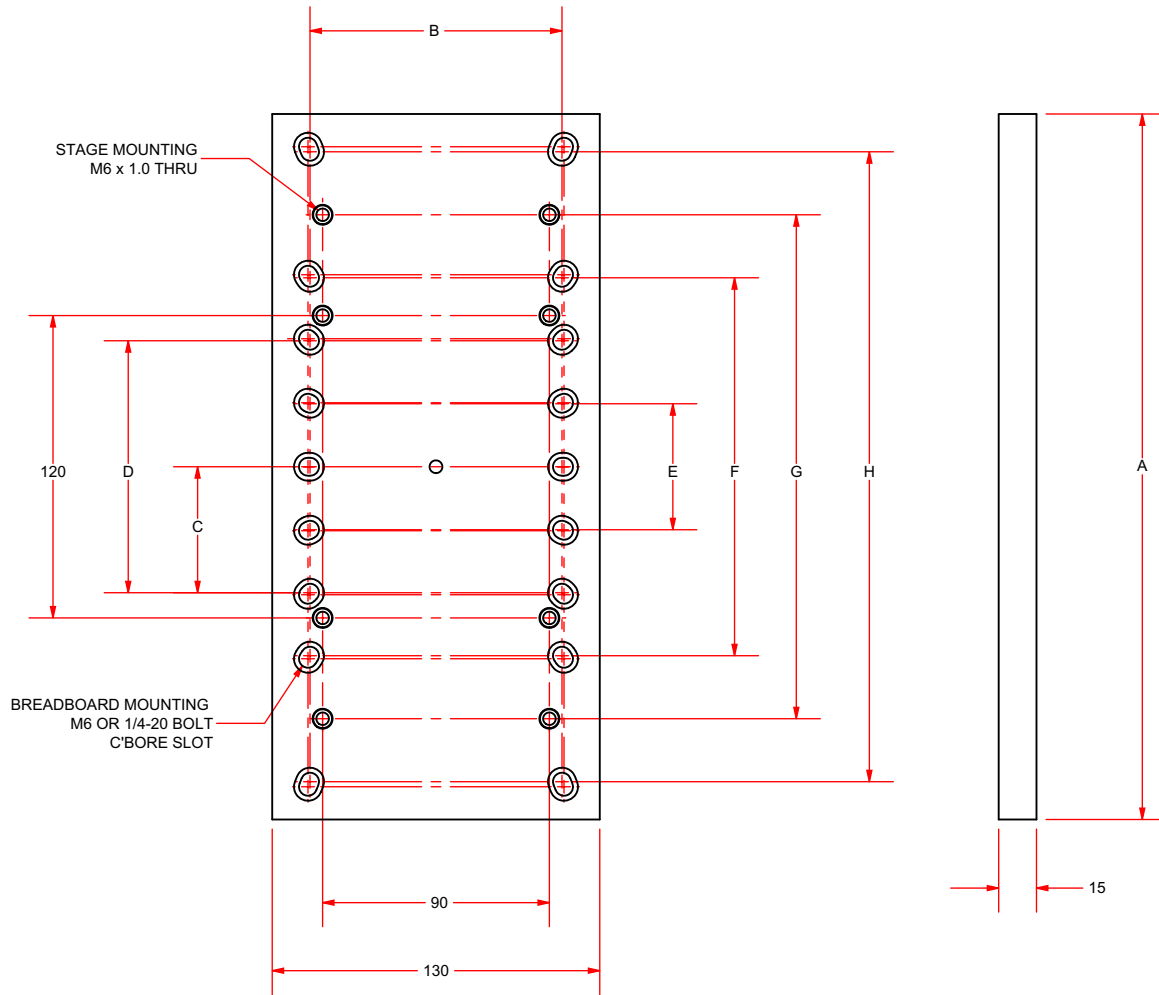

OPTION	LENGTH		MOUNTING					
	A	B	C	D	E	F	G	H
MP-ANT130-035	155	100[4.0]	50[2.0]	100[4.0]	--	--	--	--
MP-ANT130-060	180	100[4.0]	--	--	50[2.0]	150[6.0]	--	--
MP-ANT130-110	230	100[4.0]	--	--	50[2.0]	150[6.0]	200	--
MP-ANT130-160	280	100[4.0]	--	--	50[2.0]	150[6.0]	200	250[10.0]

DIMENSIONS: MILLIMETERS

# ANT130XY Post DIMENSIONS

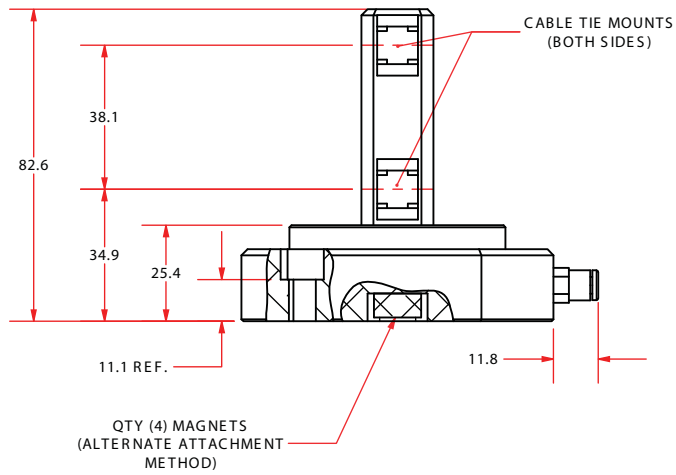
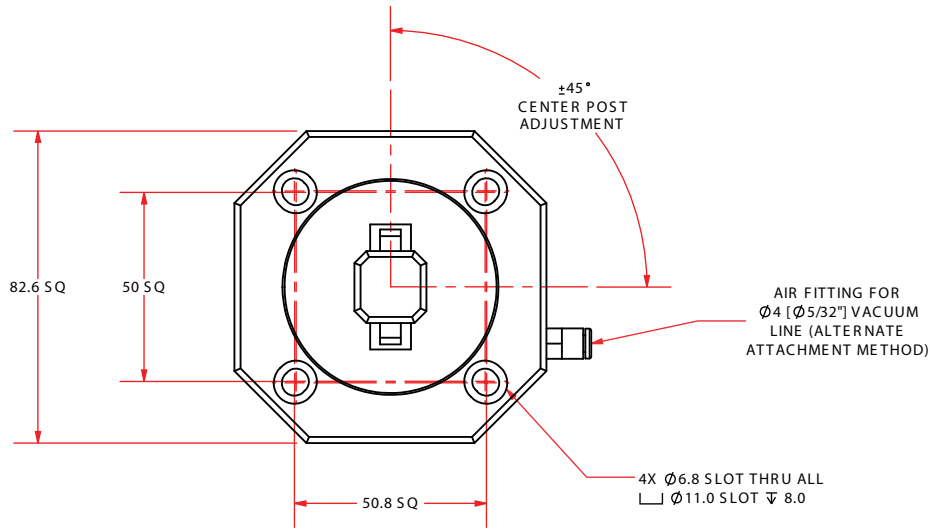

ACP2: INCLUDED WITH  
"-XY-CMS" OPTION

DIMENSIONS: MILLIMETERS

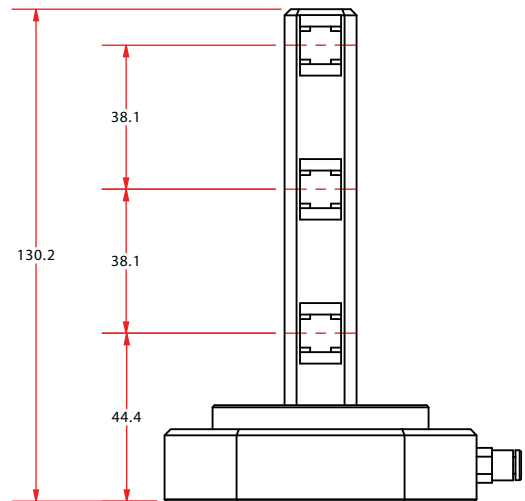

ACP3: INCLUDED WITH  
"-XYZ-CMS" OPTION

NOTE: DIMENSIONS NOT SHOWN  
ARE THE SAME AS ACP2



## ANT130XY Series ORDERING INFORMATION

### Travel (Required)

-060	60 mm travel
-110	110 mm travel
-160	160 mm travel

### Connector (Required)

-CN1	Single 25-pin D connector, 25DU
-CN2	Two connectors, 4-pin HPD and 25-pin D, 4DU-25DU

Note: -CN1 option not valid for systems using bus voltages greater than 80 V

### Cable Management(Required)

-CMS2	Post for two-axis cable support
-CMS3	Post for three-axis cable support

### Mounting Plate (Optional)

-MP	Mounting plate
-----	----------------

### Performance Grade (Required)

-PL1	Base performance
-PL3	High-accuracy performance, PLUS
-PL4	Ultra high-accuracy performance, ULTRA

### Integration (Required)

Aerotech offers both standard and custom integration services to help you get your system fully operational as quickly as possible. The following standard integration options are available for this system. Please consult Aerotech if you are unsure what level of integration is required, or if you desire custom integration support with your system.

-TAS	<p><b>Integration - Test as system</b></p> <p>Testing, integration, and documentation of a group of components as a complete system that will be used together (ex: drive, controller, and stage). This includes parameter file generation, system tuning, and documentation of the system configuration.</p>
-TAC	<p><b>Integration - Test as components</b></p> <p>Testing and integration of individual items as discrete components. This is typically used for spare parts, replacement parts, or items that will not be used or shipped together (ex: stage only). These components may or may not be part of a larger system.</p>