

X-axis Long Stroke Cross Roller Guide Stage: B12-25 (25×60) /60 (60×110)

Manual linear stage

RoHS

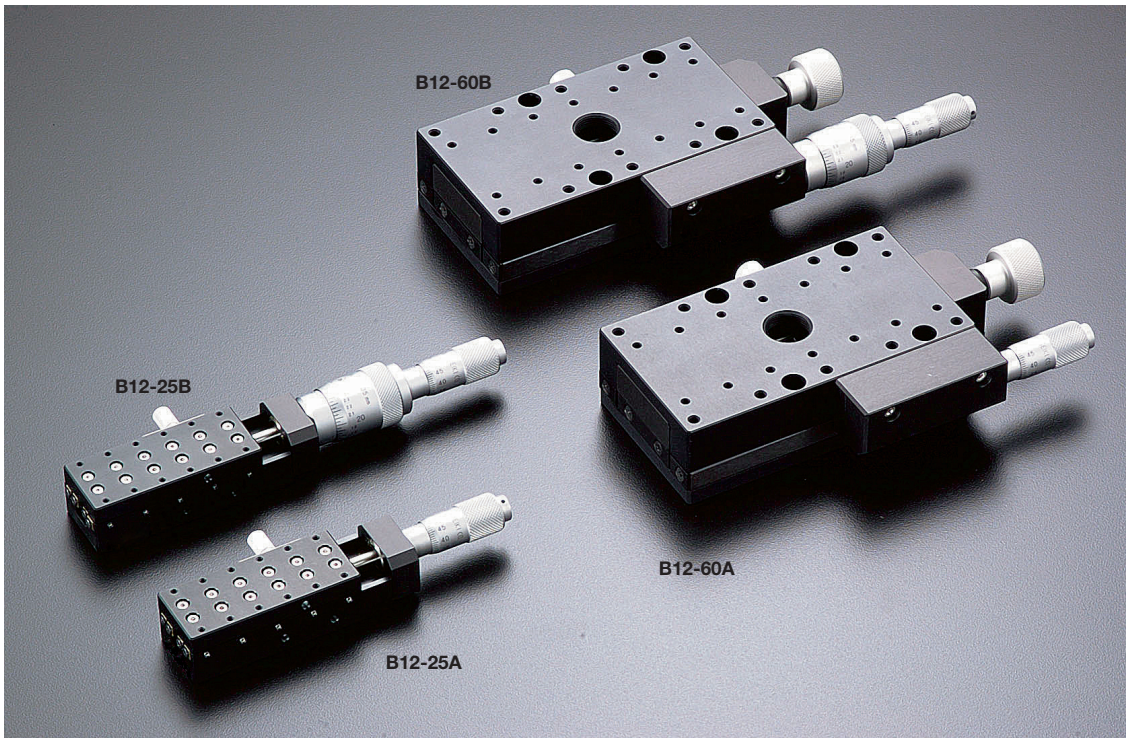

- X
- XY
- Z
- Horizontal Z
- XZ
- Horizontal XZ
- XYZ
- Horizontal XYZ

Goniometer

Rotary

Unit

Accessories

Linear Ball

Cross Roller

Dovetail

- 25
- 30
- 40
- 50
- 60
- 70
- 80
- 100
- 120

Other

[Features]

- High accuracy long stroke stage of cross roller guide.
 - Longer stroke than stages with the table size □25mm or 60mm.
 - Selectable coarse-fine micrometer.
-
- B12-60 series
Movable 40mm stroke using coarse motion knob. (3mm per rotation)
Adjustable range of 6.5mm by using a micromotion micrometer.

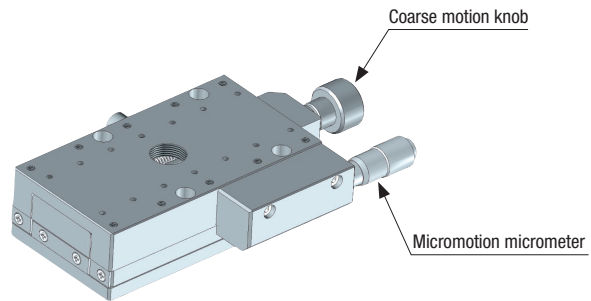

SPEC					
Model	B12-25A	B12-25B	B12-60A	B12-60B	
(Opposite hand)	B12-25AR	B12-25BR	—	—	
Stage table size	25×60mm		60×110mm		
Travel distance	±6.5mm	Coarse motion ±6.5mm Micromotion ±0.1mm	Coarse motion ±20mm Micromotion ±6.5mm		
Minimum reading of micrometer	10μm/Scale	Coarse-micromotion 0.5μm/Scale	10μm/Scale	Coarse-micromotion 0.5μm/Scale	
Guide	Cross roller guide				
Load capacity	2.0kgf [19.6N]		8.0kgf [78.4N]		
Travel accuracy	Straightness	3μm			
	Pitching	25"			
	Yawing	15"			
Allowable load for moment	Pitch	3.8N · m	8.1N · m		
	Yaw	3.2N · m	7.0N · m		
	Roll	1.5N · m	5.3N · m		
Moment rigidity	Pitch	0.19"/N · cm	0.02"/N · cm		
	Yaw	0.19"/N · cm	0.03"/N · cm		
	Roll	1.38"/N · cm	0.07"/N · cm		
Parallelism	30μm				
Motion parallelism	10μm				
Weight	0.1kg	0.2kg	0.8kg		
Main material—Surface finishing	Aluminum—Black alumite processing				
Provided screws (Hex socket screws)	2 of M4—6		Hex recessed round head screw 10 of M4—6		