

ECO225SL Series

Mechanical Bearing, Ball-Screw Stage

High-performance in a cost-effective, economic package

Rugged mechanical design

Available with servomotor or stepping motor

Nine models with travels from 100 mm to 800 mm

Vacuum and cleanroom versions available

The ECO225SL is part of the ECO linear stage family, building upon Aerotech's long tradition of producing low total cost of ownership motion designs. Excellent positioning specifications, high stiffness, and load capacity combined with economic pricing make the ECO225SL stage ideal for medium-performance production applications requiring higher load capability in a ball-screw stage.

Quality Mechanical Construction

A long-life recirculating linear guide bearing system and quality construction make the ECO225SL an attractive solution for applications where up-time is critical. Unlike low-cost competitive motion stages, the ECO225SL can be integrated into complex machines with the assurance it will perform at a high level and outlast other machine components.

Stepper Motor Option

For cost-sensitive applications, the ECO225SL series includes several NEMA 34 stepper motor options. With the ability to run on standard wall voltages, the ECO225SL provides plug-and-play capability with a minimal amount of supporting electrical equipment.

Design and Integration Flexibility

The ECO225SL is designed with many standard features and options that make the design adaptable to specific applications. It is available in nine different models with travels ranging from 100 mm to 800 mm and speeds up to 300 mm/s.



The ECO225SL-500 is one of nine models in the ECO225SL series.

The base mounting holes are accessible from the outside of the stage for easy mounting. Standard mounting holes for both English and metric optical tables are present in all travels. Each stage also mounts to another ECO225SL for easy integration of multi-axis systems.

Optional tabletops are available with either English or metric mounting patterns. A third tabletop option features hole patterns to allow the direct attachment of several types of Aerotech rotary stages.

Aerotech BM or BMS series brushless servomotors are available with a variety of encoder options providing net resolutions ranging from 0.5 μm down to sub-nm. A holding brake can be added to the motor for vertical applications. A motor fold-back kit is available for space-constrained applications to reduce the overall stage length.

The ECO225SL stage series offers many options to fit the exact requirements of numerous applications. Its flexible, cost-effective design easily makes it one of the best value linear ball-screw stage series available today.

Mechanical Specifications		ECO225SL									
		100	150	200	250	300	400	500	600	800	
Travel		100	150	200	250	300	400	500	600	800	
Accuracy ⁽¹⁾	Standard	±23 µm	±27 µm	±30 µm	±34 µm	±38 µm	±43 µm	±45 µm	±48 µm	±51 µm	
	Calibrated	±5 µm	±5 µm	±5 µm	±5.5 µm	±5.5 µm	±5.5 µm	±6 µm	±7 µm	±7 µm	
Resolution (Min. Incremental Motion)		0.2 µm ⁽²⁾ , 0.75 µm ⁽³⁾									
Bidirectional Repeatability ⁽¹⁾		±4 µm	±4 µm	±4.5 µm	±4.5 µm	±4.5 µm	±5 µm	±5 µm	±5 µm	±5 µm	
Straightness ⁽¹⁾		±2.5 µm	±3 µm	±3 µm	±3.5 µm	±4 µm	±5 µm	±6 µm	±7 µm	±9.5 µm	
Flatness ⁽¹⁾		±2.5 µm	±3 µm	±3 µm	±3.5 µm	±4 µm	±5 µm	±6 µm	±7 µm	±9.5 µm	
Pitch		40 µrad (8.3 arc sec)	40 µrad (8.3 arc sec)	50 µrad (10.3 arc sec)	55 µrad (11.3 arc sec)	60 µrad (12.4 arc sec)	70 µrad (14.4 arc sec)	85 µrad (17.5 arc sec)	100 µrad (20.6 arc sec)	110 µrad (23.7 arc sec)	
Roll		40 µrad (8.3 arc sec)	40 µrad (8.3 arc sec)	50 µrad (10.3 arc sec)	55 µrad (11.3 arc sec)	60 µrad (12.4 arc sec)	70 µrad (14.4 arc sec)	85 µrad (17.5 arc sec)	100 µrad (20.6 arc sec)	110 µrad (23.7 arc sec)	
Yaw		40 µrad (8.3 arc sec)	40 µrad (8.3 arc sec)	50 µrad (10.3 arc sec)	55 µrad (11.3 arc sec)	60 µrad (12.4 arc sec)	70 µrad (14.4 arc sec)	85 µrad (17.5 arc sec)	100 µrad (20.6 arc sec)	110 µrad (23.7 arc sec)	
Maximum Speed ⁽⁴⁾		220 mm/s									
Maximum Acceleration ⁽⁴⁾		Function of motor, amplifier selection, payload, and maximum axial load									
Load Capacity ⁽⁴⁾	Horizontal	100 kg									
	Vertical (Axial)	60 kg									
	Side	100 kg									
Moving Mass (w/tabletop)		7.4 kg									
Stage Mass (no motor)		18.5 kg	19.7 kg	20.9 kg	22.0 kg	23.2 kg	25.5 kg	27.8 kg	30.1 kg	34.8 kg	
Material		Anodized Aluminum									
MTBF (Mean Time Between Failure)		20,000 Hours									

Notes:

1. Certified with -PL1 option.
2. Achieved with Aerotech rotary motor with amplified sine encoder.
3. Achieved with Aerotech rotary motor with 2500 cnts/rev digital encoder.
4. Requires the selection of an appropriate amplifier with sufficient voltage and current.
5. Axis-orientation for on-axis loading is listed.
6. Specifications are for single-axis systems measured 25 mm above the tabletop. Performance of multi-axis systems is payload and workpoint dependent. Contact factory for multi-axis applications.
7. Specifications listed are non-foldback kit options. Contact factory for specifications when a foldback kit (-FBx) is used.

Electrical Specifications	
Drive System	Brushless Rotary Servomotor or Stepper Motor
Feedback	Incremental - 1000 lines/rev (-AS) and 2500 lines/rev (TTL)
Maximum Bus Voltage	320 VDC
Limit Switches	5 V, Normally-Closed

Recommended Controller		
Multi-Axis	A3200	Ndrive HLe/Ndrive CP/Ndrive HPe/Npaq
	Ensemble	Ensemble HLe/Ensemble CP/Ensemble HPe
Single Axis	Soloist	Soloist CP/Soloist HPe

ECO225SL Series SPECIFICATIONS

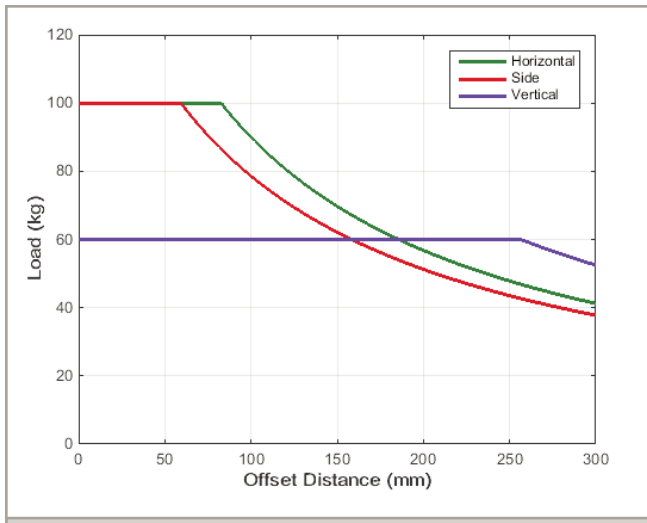

Cantilevered load capability of the ECO225SL.

ECO225SL Series DIMENSIONS

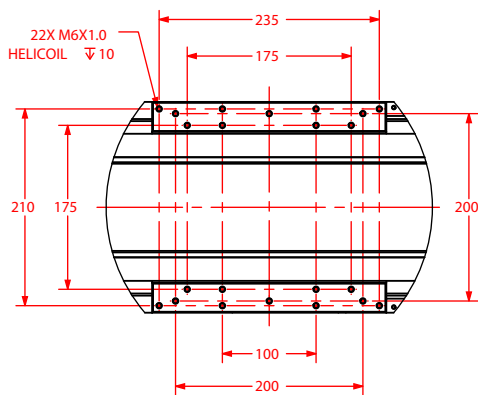
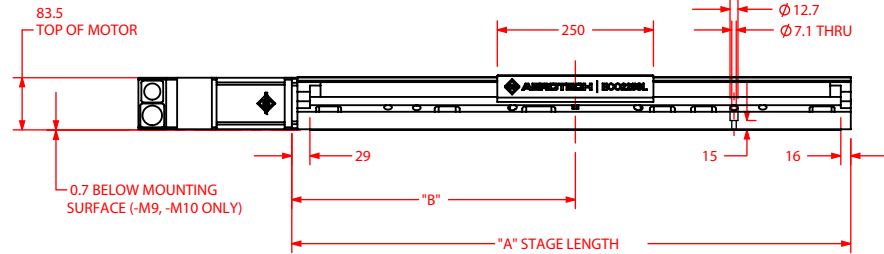
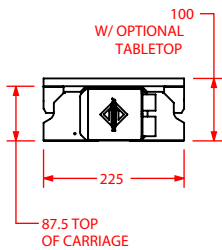
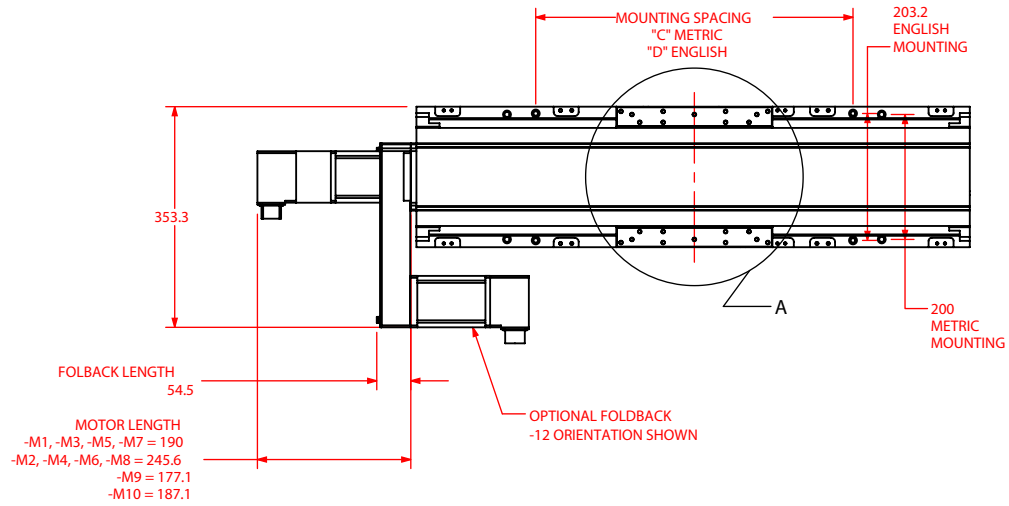
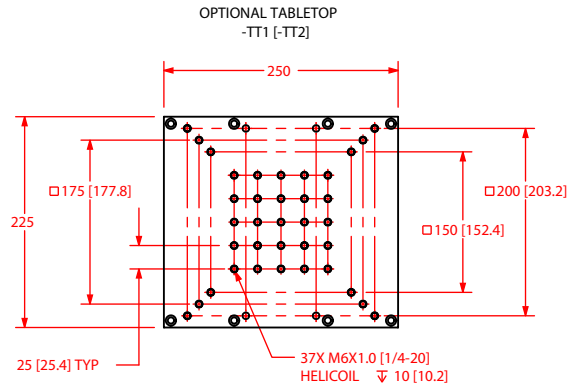
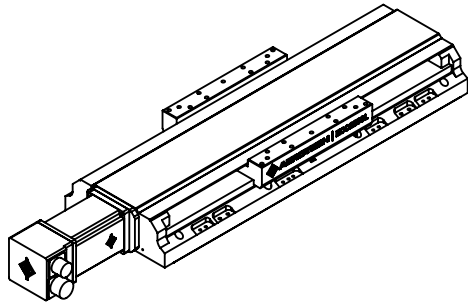

DETAIL A
CARRIAGE MOUNTING HOLES

BASIC MODEL	NOMINAL TRAVEL	ELEC LIMIT TRAVEL	MECH LIMIT TRAVEL	A	B	C	D
ECO225SL-0100	101.6	104.2-109	129.4	495	254	200, 350	203.2
ECO225SL-0150	152.4	155-159.8	179.4	545	279	200, 350	203.2
ECO225SL-0200	203.2	205.8-210.6	229.4	595	304	200, 350	203.2
ECO225SL-0250	254	256.6-261.4	279.4	645	329	200, 350	203.2
ECO225SL-0300	304.8	307.4-312.2	329.4	695	354	200, 600	203.2
ECO225SL-0400	406.4	409-413.8	429.4	795	404	200, 600	203.2, 508
ECO225SL-0500	508	510.6-515.4	529.4	895	454	200, 600	203.2, 508
ECO225SL-0600	609.6	612.2-617	629.4	995	504	200, 600	203.2, 508
ECO225SL-0800	812.8	815.4-820.2	829.4	1195	604	200, 600, 1000	203.2, 711.2

DIMENSIONS: MILLIMETERS

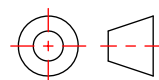

EC0225SL Series Accessory Tabletop DIMENSIONS

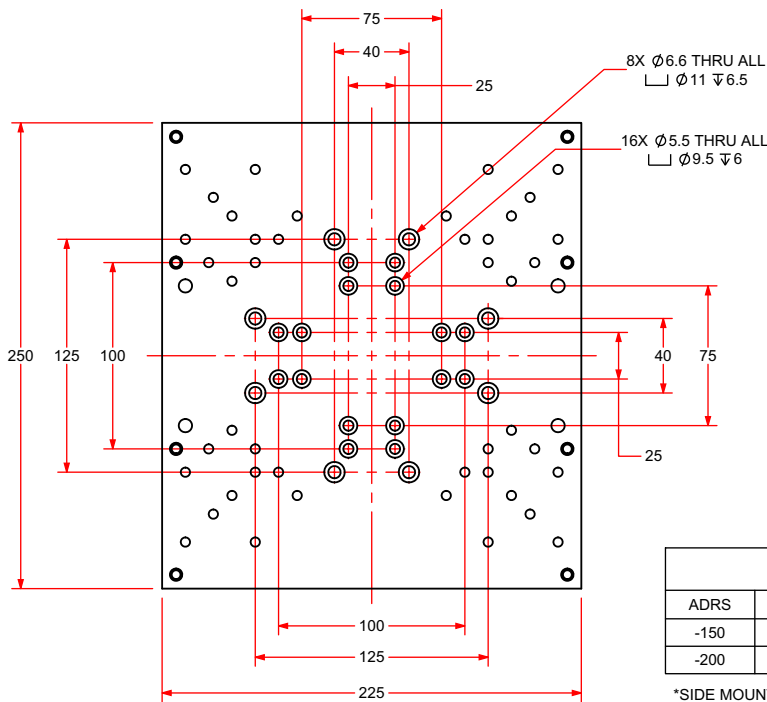
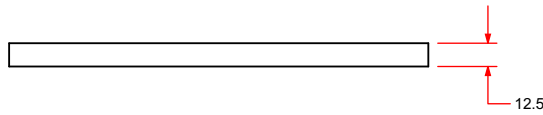
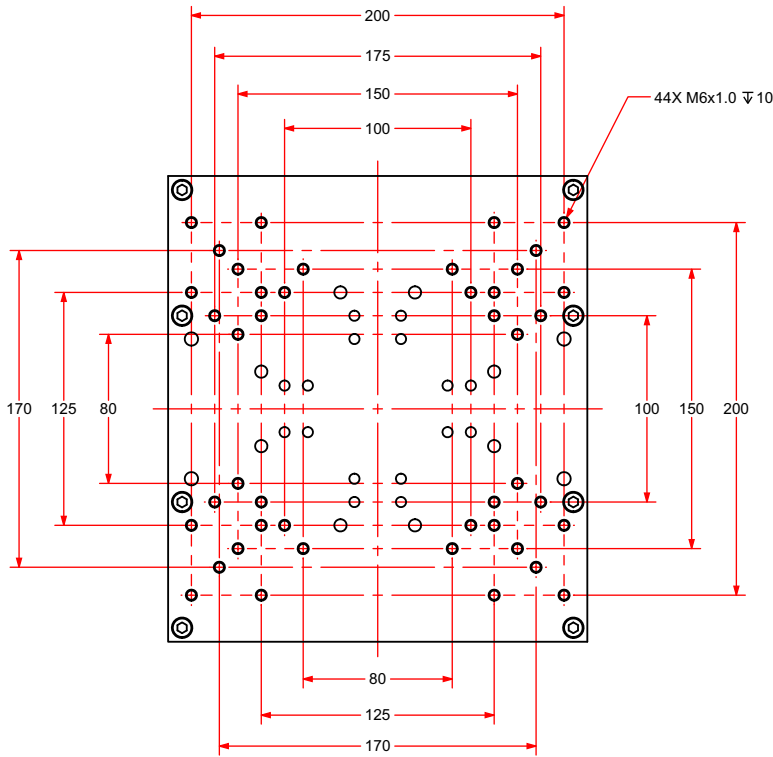

-TT3 MOUNTS THE FOLLOWING				
ADRS	ADRT	AGR	ALAR	CCS190DR
-150	-150	100	-100-SP*	-240
-200	-200	150	-100-LP*	-260

*SIDE MOUNT NOT AVAILABLE

DIMENSIONS: MILLIMETERS

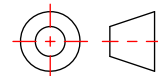

ECO225SL Series Bracket DIMENSIONS

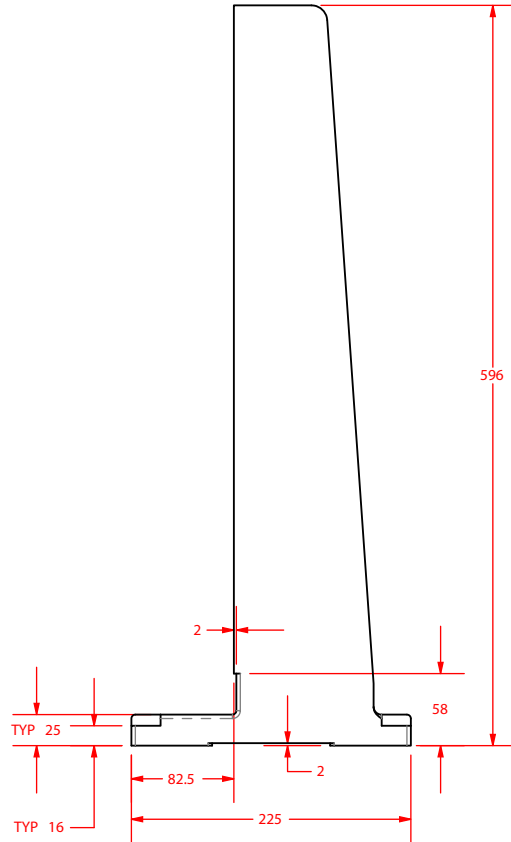
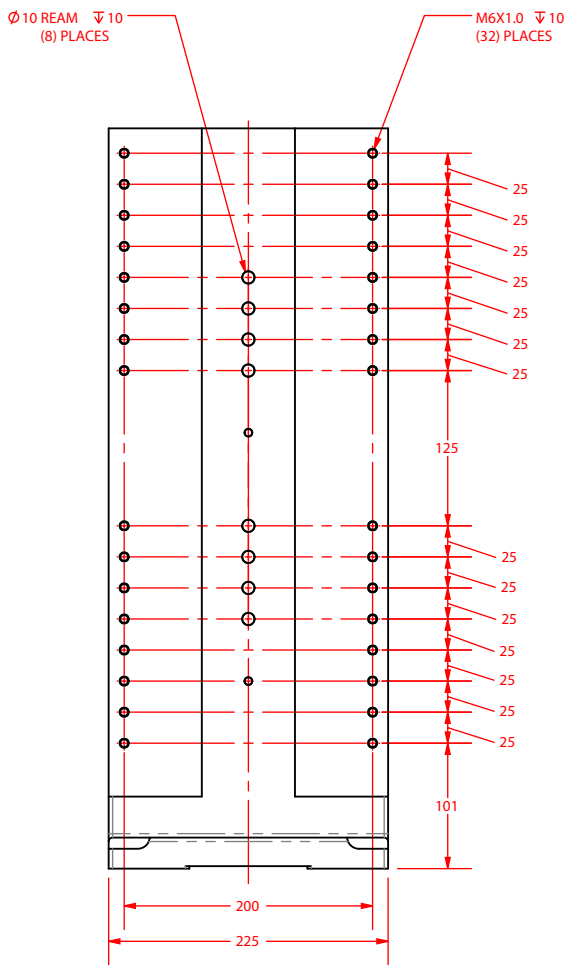
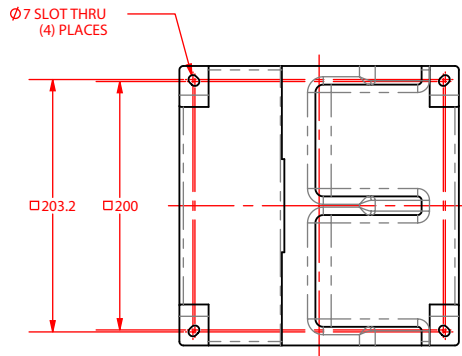

BASIC MODEL	RECOMMENDED FOR	MASS [kg]
HDZ225	PRO225SL-0100, PRO225SL-0150, PRO225SL-0200, ECO225SL-0100, ECO225SL-0150, ECO225SL-0200	16.9

DIMENSIONS: MILLIMETERS

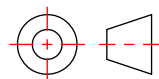

EC0225SL Series ORDERING INFORMATION

EC0225SL Series Linear, Ball-Screw Stage

Travel (Required)

-100	100 mm travel stage
-150	150 mm travel stage
-200	200 mm travel stage
-250	250 mm travel stage
-300	300 mm travel stage
-400	400 mm travel stage
-500	500 mm travel stage
-600	600 mm travel stage
-800	800 mm travel stage

Tabletop (Optional)

-TT1	Tabletop with metric dimension mounting
-TT2	Tabletop with English dimension mounting
-TT3	Accessory tabletop with mounting for select rotary stages

Motor (Optional)

-M1	BMS280 brushless servomotor and 2500-line TTL encoder
-M2	BMS280 brushless servomotor, 2500-line TTL encoder, and brake
-M3	BMS280 brushless servomotor and 1000-line 1 Vpp encoder
-M4	BMS280 brushless servomotor, 1000-line 1 Vpp encoder, and brake
-M5	BM250 brushless servomotor and 2500-line TTL encoder
-M6	BM250 brushless servomotor, 2500-line TTL encoder, and brake
-M7	BM250 brushless servomotor and 1000-line 1 Vpp encoder
-M8	BM250 brushless servomotor, 1000-line 1 Vpp encoder, and brake
-M9	SM280 high voltage stepper motor
-M10	SM280 high voltage stepper motor and brake

Foldback Kit (Optional)

-FB1	Foldback kit for 0.500 inch diameter shaft NEMA 34 motor
------	--

Motor Orientation (Optional)

-2	Bottom cable exit, optional orientation
-3	Left-side cable exit, standard orientation
-4	Top cable exit, optional orientation
-5	Right-side cable exit, optional orientation
-8	Right-side foldback, standard orientation
-12	Left-side foldback, optional orientation

Limits (Required)

-LI1	Normally-closed limit switches; 5 VDC with 9-Pin D connector
-LI2	Normally-open limit switches; 5 VDC with 9-Pin D connector

Coupling (Optional)

-CP1	Coupling for 0.500 inch diameter shaft
------	--

Lifting Hardware (Optional)

-LF	Lifting hardware
-----	------------------

Note: Lifting option only available on travels 300 mm and greater. Lifting should never be ordered on the upper-axis of an XY set (only order on lower-axis).

Metrology (Required)

-PL0	No metrology performance plots
-PL1	Metrology, uncalibrated with performance plots
-PL2	Metrology, calibrated (HALAR) with performance plots

ECO225SL Series ORDERING INFORMATION

Integration (Required)

Aerotech offers both standard and custom integration services to help you get your system fully operational as quickly as possible. The following standard integration options are available for this system. Please consult Aerotech if you are unsure what level of integration is required, or if you desire custom integration support with your system.

-TAS	Integration - Test as system Testing, integration, and documentation of a group of components as a complete system that will be used together (ex: drive, controller, and stage). This includes parameter file generation, system tuning, and documentation of the system configuration.
-TAC	Integration - Test as components Testing and integration of individual items as discrete components. This is typically used for spare parts, replacement parts, or items that will not be used or shipped together (ex: stage only). These components may or may not be part of a larger system.

Accessories (To Be Ordered As Separate Line Item)

ALIGN-NPA	Non-precision XY assembly
ALIGN-NPAZ	Non-precision XZ or YZ assembly
ALIGN-PA10	XY assembly; 10 arc sec orthogonality. Alignment to within 7 microns orthogonality for short travel stages.
ALIGN-PA10Z	XZ or YZ assembly with L-bracket; 10 arc second orthogonality. Alignment to within 10 microns orthogonality for short travel stages.
ALIGN-PA5	XY assembly; 5 arc sec orthogonality. Alignment to within 3 microns orthogonality for short travel stages.
ALIGN-PA5Z	XZ or YZ assembly with L-bracket; 5 arc second orthogonality. Alignment to within 5 microns orthogonality for short travel stages.
HDZ225	Right angle L-bracket for ECO225SL-100, ECO225SL-150, and ECO225SL-200 only.