

PRO115SL/SLE Series

Mechanical Bearing, Ball-Screw Stage

- Improved second-generation design
- High-performance in a cost-effective package
- Rugged mechanical construction
- Optional linear encoder
- 18 models with travels from 50 mm to 600 mm
- Vacuum and cleanroom versions available
- Available with built-in ThermoComp™ for high-performance in changing environments

The PRO115SL and PRO115SLE are Aerotech's second-generation PRO115 stage designs with many improvements and added features. Enhanced positioning specifications coupled with competitive pricing make the PRO115SL/SLE stage the ideal choice for both medium and high-performance applications.

Rugged Mechanical Construction

A long-life recirculating linear guide bearing system and a low-friction sealing solution make the PRO115SL/SLE an attractive solution for industrial applications such as laser machining. The basic external construction of the PRO115SL/SLE design provides protection from debris while the side-seals prevent dirt and particulates from entering the stage. The curved hard-cover design provides a natural shape that prevents excessive debris from collecting on the stage.

Linear Encoder Option

For applications requiring direct-metrology of the output carriage, the PRO115SLE integrates a direct linear encoder that is protected by the stage sealing system. Amplified sine and digital TTL output are available as standard options for the linear encoder.

Design and Integration Flexibility

The PRO115SL/SLE is designed with many standard features and options that make the design incredibly flexible and allow it to be easily tailored to a specific application. The PRO115SL/SLE is available in 18 different models with travels ranging from 50 mm to 600 mm and speeds up to 300 mm/s.

PRO Series Gen II

Up to:
 98% Higher Resolution
 46% Better Repeatability
 40% Reduction in Error Motions
 33% Improved Accuracy

Available with
ThermoComp®



The PRO115SL-300 is one of 18 models in the PRO115SL/SLE series.

The base mounting holes are accessible from the outside of the stage allowing for easy mounting. Standard mounting holes for both English and metric optical tables are present in all travels. The tabletop is available with both English and metric mounting patterns and can be ordered with brush attachments to clear any debris that may collect on the stage hard cover. Tabletops with hole patterns that allow the direct attachment of Aerotech's ADRS, ACS-LP, and AGR rotary stages are also available.

Aerotech BM or BMS series brushless servomotors are available with a variety of encoder options providing net electronic resolutions ranging from 0.5 μm down to sub-nm. A holding brake can be added to the motor for vertical applications. A motor foldback kit is available for space-constrained applications to reduce the overall stage length.

The PRO115SL/SLE series is also available with cleanroom preparation and vacuum versions.

Accurate Positioning with ThermoComp

Temperature changes and thermal effects are some of the largest error sources in precision machines, particularly in ball-screw-driven mechanics due to self-heating. All PRO series stages are available with Aerotech's ThermoComp feature, an embedded temperature compensation unit that guarantees accurate positioning not only in variable temperature environments, but during extended use of ball-screw-driven stages. Using ThermoComp protects your process from real-world positioning conditions even in extreme industrial settings.

PRO115SL/SLE Series SPECIFICATIONS

Mechanical Specifications			PRO115SL/SLE								
Travel			50	100	150	200	250	300	400	500	600
Accuracy ⁽¹⁾	SL	Standard	±6 µm	±6 µm	±8 µm	±8 µm	±9 µm	±10 µm	±12 µm	±14 µm	±16 µm
		Calibrated	±1 µm	±1.25 µm	±1.5 µm	±1.75 µm	±2 µm	±2.5 µm	±3 µm	±3.5 µm	±4 µm
	SLE	Standard	±3 µm	±4 µm	±6 µm	±8 µm	±9 µm	±10 µm	±12 µm	±14 µm	±15.5 µm
		Calibrated	±1 µm	±1 µm	±1 µm	±1.5 µm	±1.5 µm	±1.5 µm	±1.5 µm	±1.5 µm	±2 µm
Resolution (Min. Incremental Motion)		SL	0.1 µm ⁽²⁾ ; 1.0 µm ⁽³⁾								
		SLE	0.05 µm (-E1 Encoder); 0.2 µm (-E2 Encoder); 1.0 µm (-E4 Encoder)								
Bidirectional Repeatability ⁽¹⁾	SL	±1 µm	±1 µm	±1 µm	±1 µm	±1 µm	±1 µm	±1 µm	±1 µm	±1 µm	±1 µm
	SLE	±0.5 µm	±0.5 µm	±0.5 µm	±0.5 µm	±0.5 µm	±0.5 µm	±0.5 µm	±0.5 µm	±0.75 µm	±0.75 µm
Horizontal Straightness ⁽¹⁾			±1.5 µm	±2.5 µm	±3 µm	±4 µm	±5 µm	±6 µm	±8 µm	±9 µm	±10 µm
Vertical Straightness ⁽¹⁾			±1.5 µm	±2.5 µm	±3 µm	±4 µm	±5 µm	±6 µm	±8 µm	±9 µm	±10 µm
Pitch			19 µrad (3.9 arc sec)	29 µrad (6 arc sec)	29 µrad (6 arc sec)	39 µrad (8 arc sec)	49 µrad (10.1 arc sec)	58 µrad (12 arc sec)	78 µrad (16.1 arc sec)	97 µrad (20 arc sec)	116 µrad (23.9 arc sec)
Roll			19 µrad (3.9 arc sec)	29 µrad (6 arc sec)	29 µrad (6 arc sec)	39 µrad (8 arc sec)	49 µrad (10.1 arc sec)	58 µrad (12 arc sec)	78 µrad (16.1 arc sec)	97 µrad (20 arc sec)	116 µrad (23.9 arc sec)
Yaw			19 µrad (3.9 arc sec)	29 µrad (6 arc sec)	29 µrad (6 arc sec)	39 µrad (8 arc sec)	49 µrad (10.1 arc sec)	58 µrad (12 arc sec)	78 µrad (16.1 arc sec)	97 µrad (20 arc sec)	116 µrad (23.9 arc sec)
Maximum Speed ⁽⁴⁾			300 mm/s								
Maximum Acceleration ⁽⁴⁾			Function of Motor, Amplifier Selection, Payload, and Maximum Axial Load								
Load Capacity ⁽⁵⁾	Horizontal		40 kg								
	Vertical (Axial)		18 kg								
	Side		40 kg								
Moving Mass (w/Tabletop)	SL		1.4 kg								
	SLE		1.6 kg								
Stage Mass (No Motor)	SL		4.0 kg	4.4 kg	4.8 kg	5.2 kg	5.6 kg	6.0 kg	6.8 kg	7.6 kg	8.4 kg
	SLE		4.5 kg	4.9 kg	5.3 kg	5.8 kg	6.2 kg	6.6 kg	7.5 kg	8.4 kg	9.3 kg
Material			Anodized Aluminum								
MTBF (Mean Time Between Failure)			20,000 Hours								

Notes:

1. Certified with -PL1/PL2 options.
2. Achieved with Aerotech rotary motor with amplified sine encoder.
3. Achieved with Aerotech rotary motor with 2500 cnts/rev digital encoder.
4. Requires the selection of an appropriate amplifier with sufficient voltage and current.
5. Axis-orientation for on-axis loading is listed.
6. Specifications are for single-axis systems measured 25 mm above the tabletop. Performance of multi-axis systems is payload and workpoint dependent. Contact factory for multi-axis applications.
7. Specifications listed are non-foldback kit options. Contact factory for specifications when a foldback kit (-FBx) is used.

Electrical Specifications	
Drive System	Brushless Rotary Servomotor
Feedback (Linear Encoder – SLE Version Only)	Incremental – 1 Vpp and TTL (0.1 µm & 0.5 µm) Output
Feedback (Rotary Encoder)	Incremental – 1000 lines/rev (1 Vpp) and 2500 lines/rev (TTL)
Maximum Bus Voltage	320 VDC
Limit Switches	5 V, Normally-Closed

Notes:

1. Certified with -PLOTS option.

Recommended Controller		
Multi-Axis	A3200	Ndrive HLe/Ndrive CP/Ndrive HPe/Npaq
	Ensemble	Ensemble HLe/Ensemble CP/Ensemble HPe
Single Axis	Soloist	Soloist CP/Soloist HPe

PRO115SL/SLE Series SPECIFICATIONS

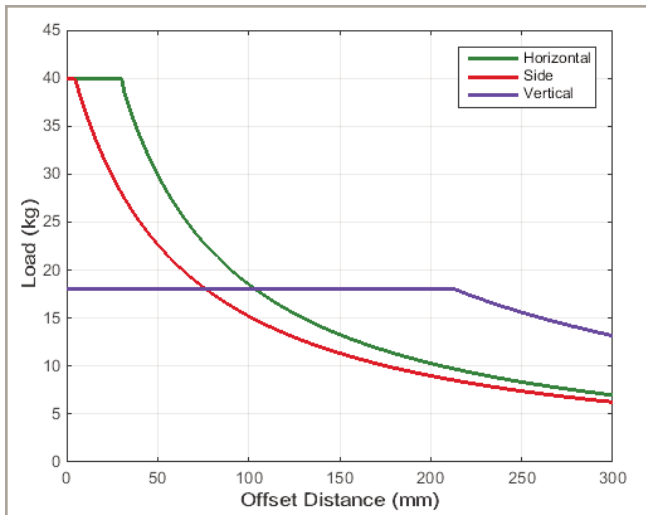

Cantilevered load capability of the PRO115SL/SLE.

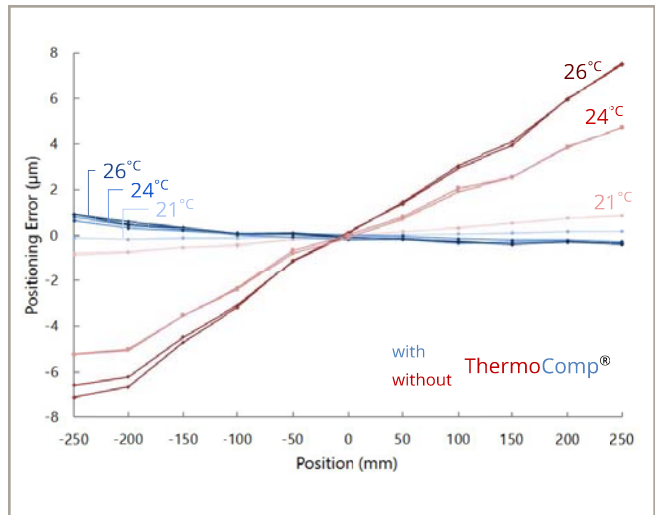

Measurement data showing successful compensation of thermal related positioning errors at several temperatures using the ThermoComp feature. Results are typical of stage performance with and without ThermoComp.

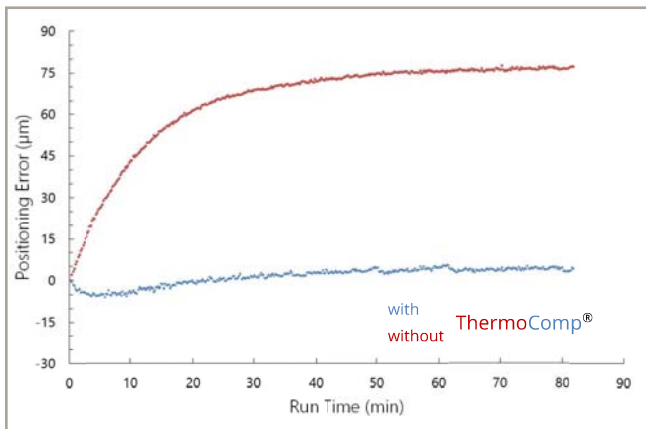

Measurement data showing successful compensation of internal heating related positioning errors during prolonged operation of a ball screw stage using the ThermoComp feature. Results are typical of ball screw stage performance with and without ThermoComp.

PRO115SL/SLE Series DIMENSIONS

PRO115SL

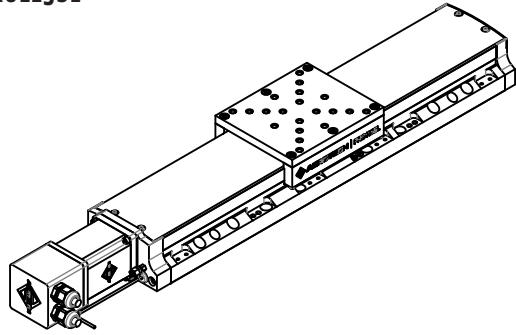

OPTIONAL TABLETOP
-TT1 [-TT2]

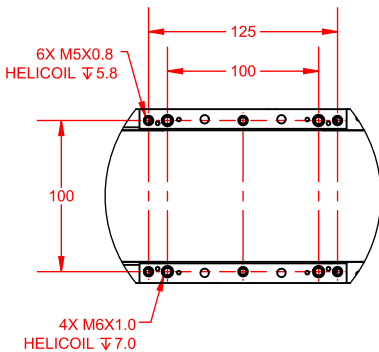
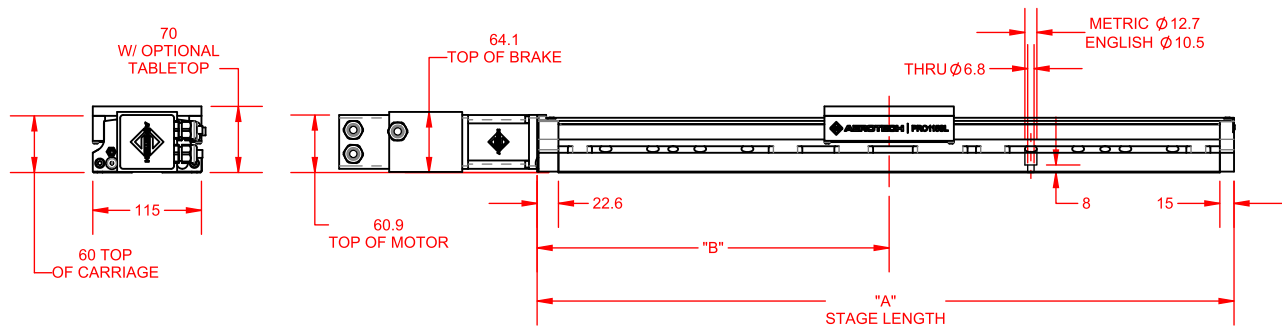
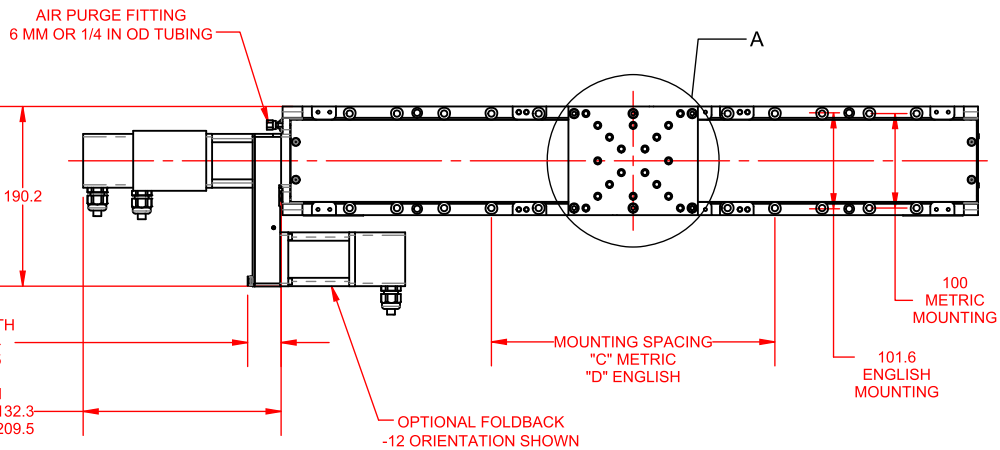
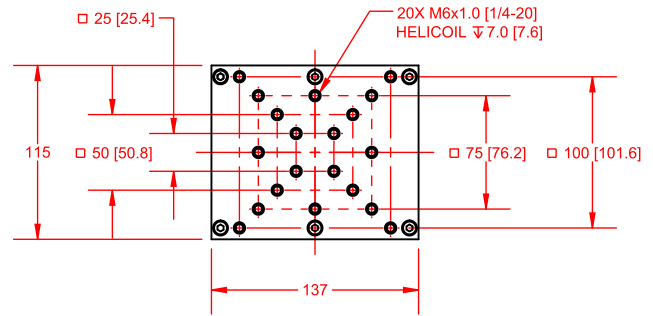

DETAIL A
CARRIAGE MOUNTING HOLES

BASIC MODEL	NOMINAL TRAVEL	ELEC LIMIT TRAVEL	MECH LIMIT TRAVEL	A	B	C	D
PRO115SL-050	50.8	58.4-63.2	75	287.6	147.6	100	101.6
PRO115SL-100	101.6	109.2-114	125	337.6	172.6	100, 200	101.6
PRO115SL-150	152.4	160-164.8	175	387.6	197.6	100, 200	101.6
PRO115SL-200	203.2	210.8-215.6	225	437.6	222.6	100, 200, 300	101.6
PRO115SL-250	254	261.8-266.4	275	487.6	247.6	100, 200, 300	101.6, 355.6
PRO115SL-300	304.8	312.4-317.2	325	537.6	272.6	100, 200, 300, 400	101.6, 355.6
PRO115SL-400	406.4	414-418.8	425	637.6	322.6	100, 200, 300, 400, 500	101.6, 457.2
PRO115SL-500	508	515.6-519	525	737.6	372.6	100, 200, 300, 400, 500, 600	101.6, 457.2
PRO115SL-600	609.6	617.2-619	625	837.6	422.6	100, 200, 300, 400, 500, 600, 700	101.6, 457.2, 660.4

NOTES :

OPTIONAL TABLETOP -TT1 TABLETOP OPTION REQUIRED FOR LOWER AXIS OF XY ASSEMBLIES WHEN FOLDBACK OPTION IS CHOSEN.

2. DIMENSIONS: MILLIMETERS.

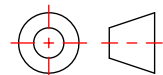

PRO115SL/SLE Series DIMENSIONS

PRO115SLE

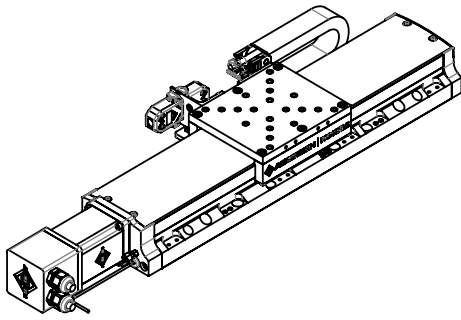

TABLETOP
-TT1 [-TT2]

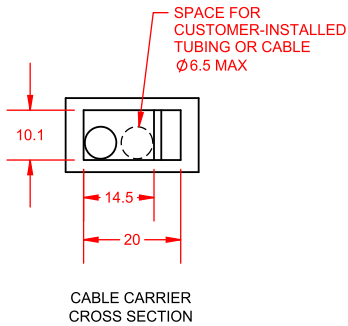
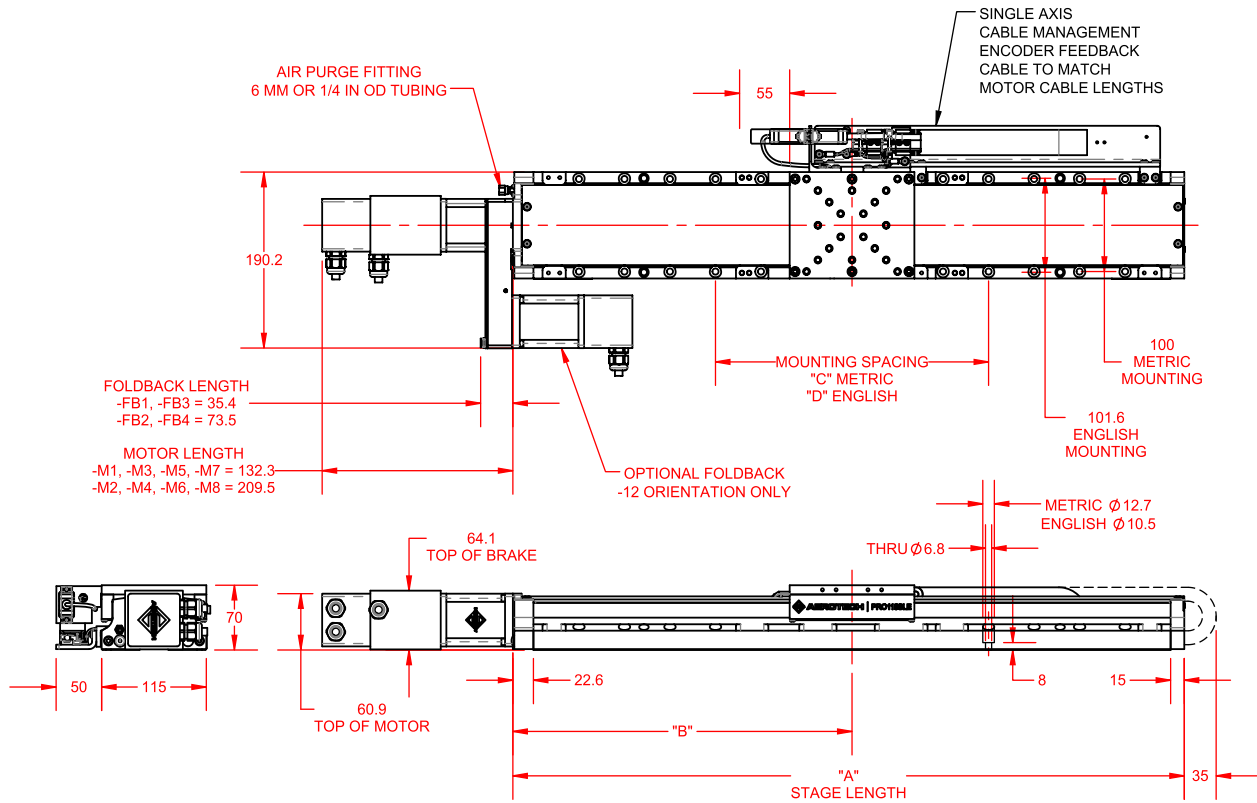
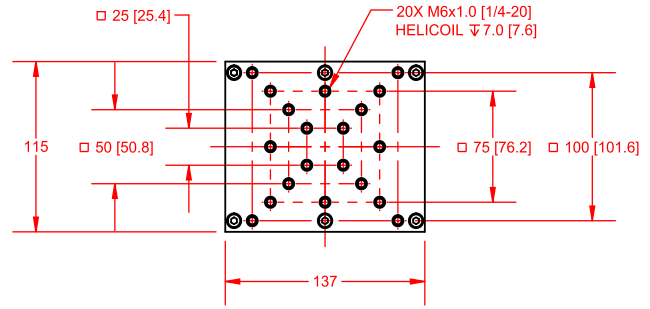

BASIC MODEL	NOMINAL TRAVEL	ELEC LIMIT TRAVEL	MECH LIMIT TRAVEL	A	B	C	D
PRO115SLE-050	50.8	58.4-63.2	75	287.6	147.6	100	101.6
PRO115SLE-100	101.6	109.2-114	125	337.6	172.6	100, 200	101.6
PRO115SLE-150	152.4	160-164.8	175	387.6	197.6	100, 200	101.6
PRO115SLE-200	203.2	210.8-215.6	225	437.6	222.6	100, 200, 300	101.6
PRO115SLE-250	254	261.8-266.4	275	487.6	247.6	100, 200, 300	101.6, 355.6
PRO115SLE-300	304.8	312.4-317.2	325	537.6	272.6	100, 200, 300, 400	101.6, 355.6
PRO115SLE-400	406.4	414-418.8	425	637.6	322.6	100, 200, 300, 400, 500	101.6, 457.2
PRO115SLE-500	508	515.6-519	525	737.6	372.6	100, 200, 300, 400, 500, 600	101.6, 457.2
PRO115SLE-600	609.6	617.2-619	625	837.6	422.6	100, 200, 300, 400, 500, 600, 700	101.6, 457.2, 660.4

NOTES :

TABLETOP OPTION REQUIRED FOR LOWER AXIS OF XY ASSEMBLIES WHEN FOLDBACK OPTION IS CHOSEN.

2. DIMENSIONS: MILLIMETERS.

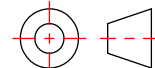

PR0115SL/SLE Series Accessory Tabletop DIMENSIONS

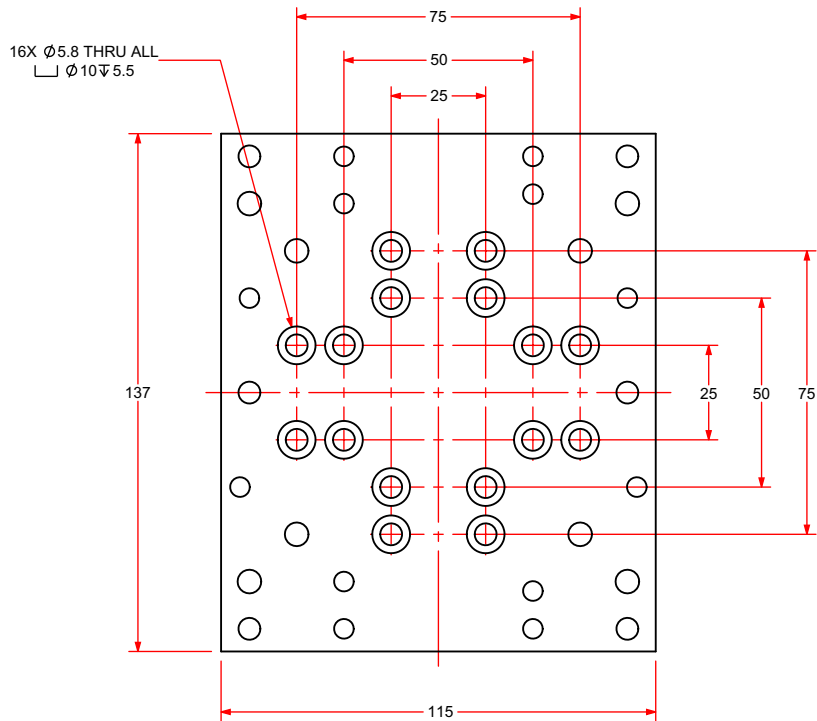
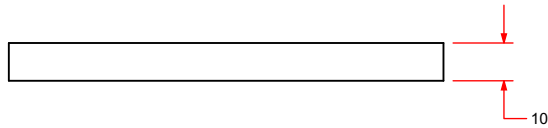
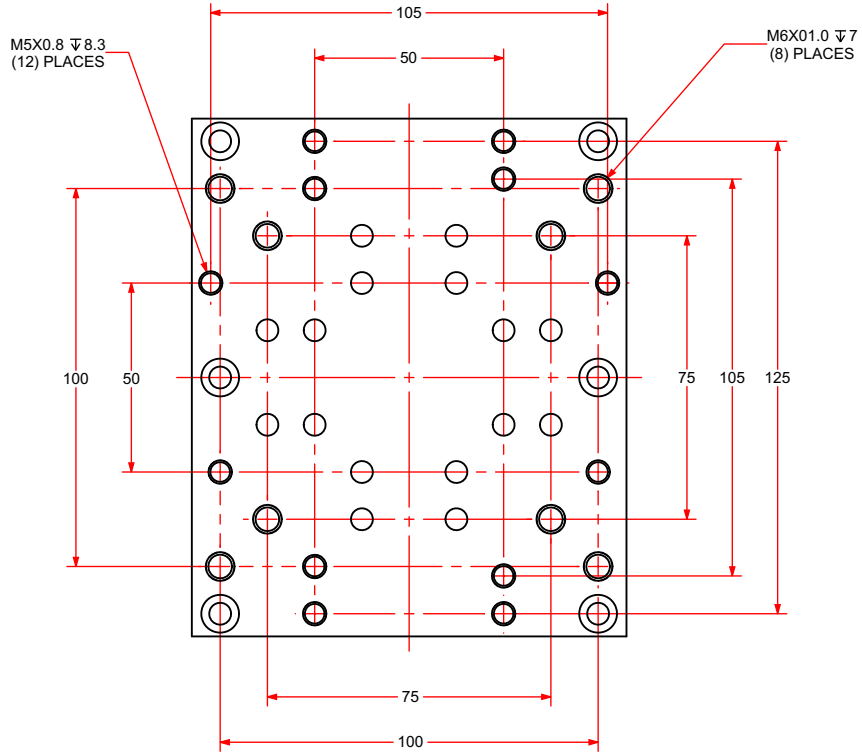

-TT3 MOUNTS THE FOLLOWING	
ADRS	AGR
-100	50
	75

DIMENSIONS: MILLIMETERS

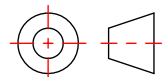

PRO115SL/SLE Series HDZ Bracket DIMENSIONS

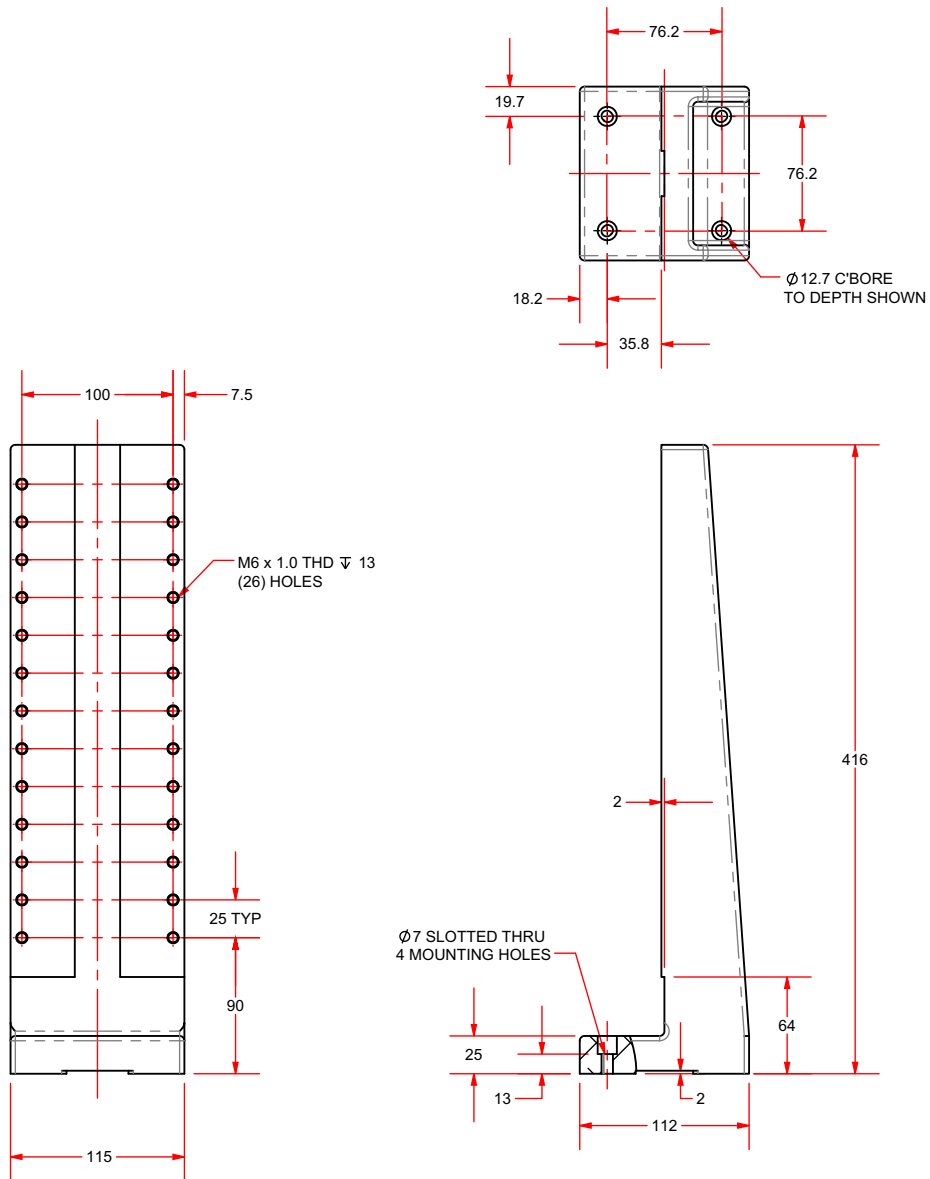

BASIC MODEL	RECOMMENDED FOR	MASS [kg]
HDZ115	PRO115SL-050, PRO115SL-100, PRO115SL-150	3.7

DIMENSIONS: MILLIMETERS

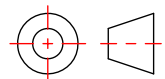

PRO115SL/SLE Series ORDERING INFORMATION

PRO115SL Series Linear, Ball-Screw Stage

Travel (Required)

-050	50 mm travel stage
-100	100 mm travel stage
-150	150 mm travel stage
-200	200 mm travel stage
-250	250 mm travel stage
-300	300 mm travel stage
-400	400 mm travel stage
-500	500 mm travel stage
-600	600 mm travel stage

Tabletop (Optional)

-TT1	Tabletop with metric dimension mounting
-TT2	Tabletop with English dimension mounting
-TT3	Accessory tabletop with mounting for select rotary stages
-TT4	Tabletop with metric dimension mounting and wiper brushes
-TT5	Tabletop with English dimension mounting and wiper brushes
-TT6	Accessory tabletop with mounting for select rotary stages and wipers

Motor (Optional)

-M1	BMS60 brushless servomotor and 2500-line TTL encoder
-M2	BMS60 brushless servomotor, 2500-line TTL encoder, and brake
-M3	BMS60 brushless servomotor and 1000-line 1 Vpp encoder
-M4	BMS60 brushless servomotor, 1000-line 1 Vpp encoder, and brake
-M5	BM75 brushless servomotor and 2500-line TTL encoder
-M6	BM75 brushless servomotor, 2500-line TTL encoder, and brake
-M7	BM75 brushless servomotor and 1000-line 1 Vpp encoder
-M8	BM75 brushless servomotor, 1000-line 1 Vpp encoder, and brake

Foldback (Optional)

-FB1	Foldback kit for 0.250 inch diameter shaft NEMA 23 motor
-FB2	Foldback kit with brake for 0.250 inch diameter shaft NEMA 23 motor
-FB3	Foldback kit for 0.375 inch diameter shaft NEMA 23 motor
-FB4	Foldback kit with brake for 0.375 inch diameter shaft NEMA 23 motor

Note: TT option required for lower axis of XY when a foldback kit is used.

Motor Orientation (Optional)

-2	Bottom cable exit, optional orientation
-3	Left-side cable exit, standard orientation
-4	Top cable exit, optional orientation
-5	Right-side cable exit, optional orientation
-8	Right-side foldback, standard orientation
-12	Left-side foldback, optional orientation

Limits (Required)

-LI1	Normally-closed limit switches; 5 VDC with 9-Pin D connector
-LI2	Normally-open limit switches; 5 VDC with 9-Pin D connector
-LI3	Normally-closed limit switches; 24 VDC with 9-Pin D connector

Coupling (Optional)

-CP1	Coupling for 0.250 inch diameter shaft
-CP2	Coupling for 0.375 inch diameter shaft

ThermoComp (Optional)

-TCMP	ThermoComp integrated thermal compensation, single or lower axis
-------	--

Note: An A3200 controller must be used with the -TCMP option.

Metrology (Required)

-PL0	No metrology performance plots
-PL1	Metrology, uncalibrated with performance plots
-PL2	Metrology, calibrated (HALAR) with performance plots

PRO115SL/SLE Series ORDERING INFORMATION

Integration (Required)

Aerotech offers both standard and custom integration services to help you get your system fully operational as quickly as possible. The following standard integration options are available for this system. Please consult Aerotech if you are unsure what level of integration is required, or if you desire custom integration support with your system.

-TAS	Integration - Test as system Testing, integration, and documentation of a group of components as a complete system that will be used together (ex: drive, controller, and stage). This includes parameter file generation, system tuning, and documentation of the system configuration.
-TAC	Integration - Test as components Testing and integration of individual items as discrete components. This is typically used for spare parts, replacement parts, or items that will not be used or shipped together (ex: stage only). These components may or may not be part of a larger system.

Accessories (To Be Ordered As Separate Line Item)

ALIGN-NPA	Non-precision XY assembly
ALIGN-NPAZ	Non-precision XZ or YZ assembly
ALIGN-PA10	XY assembly; 10 arc sec orthogonality. Alignment to within 7 microns orthogonality for short travel stages.
ALIGN-PA10Z	XZ or YZ assembly with L-bracket; 10 arc second orthogonality. Alignment to within 10 microns orthogonality for short travel stages.
ALIGN-PA5	XY assembly; 5 arc sec orthogonality. Alignment to within 3 microns orthogonality for short travel stages.
ALIGN-PA5Z	XZ or YZ assembly with L-bracket; 5 arc second orthogonality. Alignment to within 5 microns orthogonality for short travel stages.
HDZ115	Right angle L-bracket for PRO115SL/SLE-050, PRO115SL/SLE-100, and PRO115SL/SLE-150 only.

Note: HDZ bracket requires a tabletop when mounting to a PRO stage.

PRO115SLE Series Linear, Ball-Screw Stage with Direct Linear Feedback

Direct Linear Feedback (Required)

-E1	Incremental linear encoder; 1 Vpp
-E2	Incremental linear encoder; 0.1 μ m digital TTL output
-E4	Incremental linear encoder, 0.5 μ m digital TTL output

Travel (Required)

-050	50 mm travel stage
-100	100 mm travel stage
-150	150 mm travel stage
-200	200 mm travel stage
-250	250 mm travel stage
-300	300 mm travel stage
-400	400 mm travel stage
-500	500 mm travel stage
-600	600 mm travel stage

Tabletop (Required)

-TT1	Tabletop with metric dimension mounting
-TT2	Tabletop with English dimension Mounting
-TT3	Accessory tabletop with mounting for select rotary stages
-TT4	Tabletop with metric dimension mounting and wiper brushes
-TT5	Tabletop with English dimension mounting and wiper brushes
-TT6	Accessory tabletop with mounting for select rotary stages and wipers

Motor (Optional)

-M1	BMS60 brushless servomotor and 2500-line TTL encoder
-M2	BMS60 brushless servomotor, 2500-line TTL encoder, and brake
-M3	BMS60 brushless servomotor and 1000-line 1 Vpp encoder
-M4	BMS60 brushless servomotor, 1000-line 1 Vpp encoder, and brake
-M5	BM75 brushless servomotor and 2500-line TTL encoder
-M6	BM75 brushless servomotor, 2500-line TTL encoder, and brake
-M7	BM75 brushless servomotor and 1000-line 1 Vpp encoder
-M8	BM75 brushless servomotor, 1000-line 1 Vpp encoder, and brake

PRO115SL/SLE Series ORDERING INFORMATION

Foldback (Optional)

-FB1	Foldback kit for 0.250 inch diameter shaft NEMA 23 motor
-FB2	Foldback kit with brake for 0.250 inch diameter shaft NEMA 23 motor
-FB3	Foldback kit for 0.375 inch diameter shaft NEMA 23 motor
-FB4	Foldback kit with brake for 0.375 inch diameter shaft NEMA 23 motor

Motor Orientation (Optional)

-2	Bottom cable exit, optional orientation
-3	Left-side cable exit, standard orientation
-4	Top cable exit, optional orientation
-5	Right-side cable exit, optional orientation
-8	Right-side foldback, standard orientation
-12	Left-side foldback, optional orientation

Limits (Required)

-LI1	Normally-closed limit switches; 5 VDC with 9-Pin D connector
-LI2	Normally-open limit switches; 5 VDC with 9-Pin D connector
-LI3	Normally-closed limit switches; 24 VDC with 9-Pin D connector

Coupling (Optional)

-CP1	Coupling for 0.250 inch diameter shaft
-CP2	Coupling for 0.375 inch diameter shaft

ThermoComp (Optional)

-TCMP	ThermoComp integrated thermal compensation, single or lower axis
-------	--

Note: An A3200 controller must be used with the -TCMP option.

Metrology (Required)

-PL0	No metrology performance plots
-PL1	Metrology, uncalibrated with performance plots
-PL2	Metrology, calibrated (HALAR) with performance plots

Integration (Required)

Aerotech offers both standard and custom integration services to help you get your system fully operational as quickly as possible. The following standard integration options are available for this system. Please consult Aerotech if you are unsure what level of integration is required, or if you desire custom integration support with your system.

-TAS	Integration - Test as system Testing, integration, and documentation of a group of components as a complete system that will be used together (ex: drive, controller, and stage). This includes parameter file generation, system tuning, and documentation of the system configuration.
-TAC	Integration - Test as components Testing and integration of individual items as discrete components. This is typically used for spare parts, replacement parts, or items that will not be used or shipped together (ex: stage only). These components may or may not be part of a larger system.

Accessories (To Be Ordered As Separate Line Item)

ALIGN-NPA	Non-precision XY assembly
ALIGN-NPAZ	Non-precision XZ or YZ assembly
ALIGN-PA10	XY assembly; 10 arc sec orthogonality. Alignment to within 7 microns orthogonality for short travel stages.
ALIGN-PA10Z	XZ or YZ assembly with L-bracket; 10 arc second orthogonality. Alignment to within 10 microns orthogonality for short travel stages.
ALIGN-PA5	XY assembly; 5 arc sec orthogonality. Alignment to within 3 microns orthogonality for short travel stages.
ALIGN-PA5Z	XZ or YZ assembly with L-bracket; 5 arc second orthogonality. Alignment to within 5 microns orthogonality for short travel stages.
HDZ115	Right angle L-bracket for PRO115SL/SLE-050, PRO115SL/SLE-100, and PRO115SL/SLE-150 only.

Note: HDZ bracket requires a tabletop when mounting to a PRO stage.