

ALS2200 Series

Mechanical Bearing, Linear Motor Stage

Fully enclosed design

Exceptionally smooth and cog-free motion

Powerful linear brushless servomotor

High accuracy

Outstanding straightness/flatness

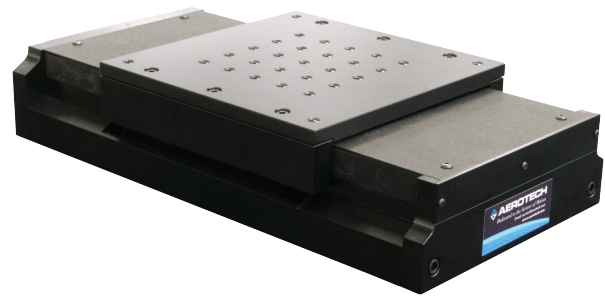

By combining a powerful linear motor drive with high-accuracy crossed-roller bearings and a fully sealed system, the ALS2200 is a production-grade stage with exceptional performance.

Superior Construction

Designed for applications requiring exceptional smoothness of travel, the ALS2200 utilizes precision crossed-roller bearings. Since there are no recirculating elements, vibration throughout travel is minimized, resulting in outstanding velocity stability. Machined from a stress-relieved special aluminum-alloy extruded base, the ALS2200 has excellent stiffness and long-term stability.

Linear Motor Drive

The ALS2200 utilizes an ironless core so it is a cog-free design. The lack of cogging enables extremely tight velocity control, as well as superior contour motion

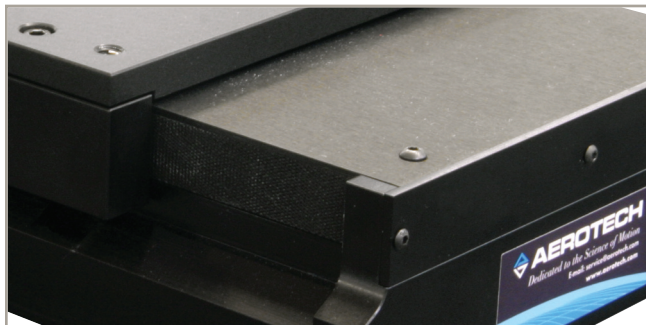

The vertical side-seal design provides superior protection from debris.

profiles. As with all of Aerotech's ALS series stages, there is zero backlash, no windup, zero friction, and outstanding system responsiveness.

Outstanding Resolution

Many applications require outstanding step-to-step resolution. The ALS2200 meets this demand with a resolution of 3 nm when coupled with Aerotech control products. The direct-drive linear motor allows the ALS2200 to make precise, small resolution steps that are particularly important in alignment applications where step accuracy is critical.

Enclosed Design

To protect the stage from debris and particulates, the ALS2200 incorporates a full-length metal waycover and advanced sealing system. Tensioned side straps are used in lieu of bellows which are difficult to keep clean and increase the overall stage profile. The straps are in a vertical orientation that prevents debris from accumulating, and the straps are under constant tension to create a tight seal.

Convenient Assembly

The tabletop of the ALS2200 is treated with a protective, scratch-resistant, Teflon®-impregnated hardcoat (Rockwell 62 hardness). All of the tabletop mounting holes utilize stainless-steel Helicoil® inserts to protect against thread wear. The base mounting holes are located outboard of the stage, which allows the stage to be mounted without removing the hardcover.

The ALS2200 utilizes a moving magnet design in the linear-motor drive mechanism. As a result, there are no moving cables and therefore no cable management system, simplifying system interconnection.

ALS2200 Series SPECIFICATIONS

Mechanical Specifications		ALS22010	ALS22015
Travel		100 mm	150 mm
Accuracy ⁽¹⁾	Standard	±4.0 µm	±6.0 µm
	Calibrated	±0.75 µm	
Resolution		3 nm	
Repeatability ⁽¹⁾ (Bi-Directional)		±0.2 µm	
Repeatability ⁽¹⁾ (Uni-Directional)		±0.1 µm	
Straightness ⁽¹⁾		±1.5 µm	±2.0 µm
Flatness ⁽¹⁾		±1.5 µm	±2.0 µm
Pitch		10 arc sec	14 arc sec
Roll		10 arc sec	14 arc sec
Yaw		8 arc sec	10 arc sec
Maximum Speed		500 mm/s	
Maximum Acceleration		1 g - 10 m/s ²	
Maximum Force (Continuous)		32.4 N	
Load Capacity ⁽²⁾	Horizontal	30 kg	
	Side	30 kg	
Moving Mass		6.4 kg	7.4 kg
Stage Mass		14 kg	16 kg
Material		Aluminum	
MTBF (Mean Time Between Failure)		20,000 Hours	

Notes:

1. Certified with each stage.
2. Axis orientation for on-axis loading is listed.
3. Specifications are for single-axis systems measured 25 mm above the table top. Performance of multi-axis systems is payload and workpoint dependent. Consult factory for multi-axis or non-standard applications.

Electrical Specifications

Drive System	Brushless Linear Servomotor
Feedback	Noncontact Linear Encoder
Maximum Bus Voltage	320 VDC
Limit Switches	5 V, Normally Closed/Normally Open
Home Switch	Near Center

Recommended Controller

Multi-Axis	A3200	MP/CP/HPe/CL/HLe
	Ensemble	MP/CP/HPe/CL/HLe
Single Axis	Soloist	MP/CP/HPe/CL/HLe

ALS2200 Series DIMENSIONS

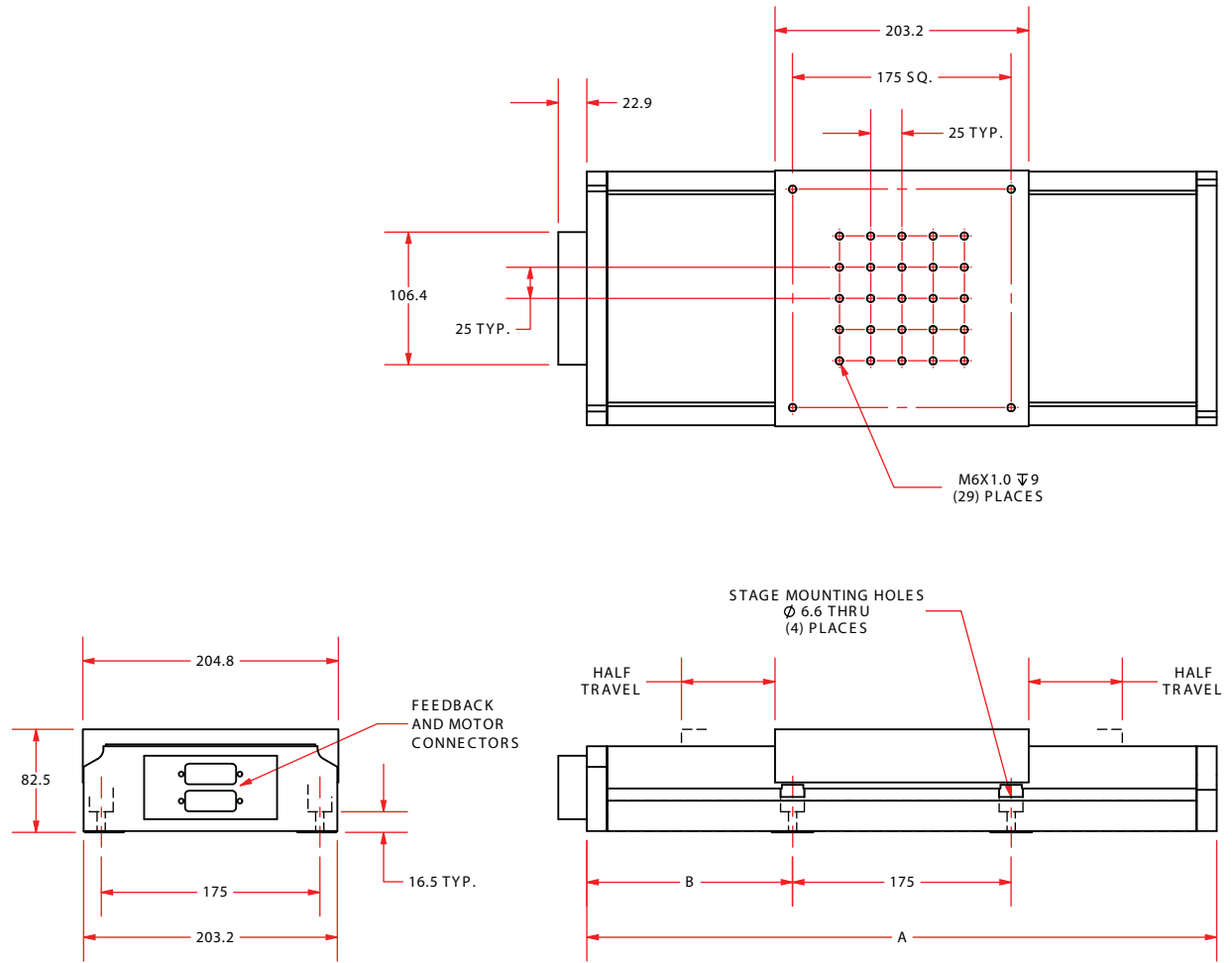

DIMENSIONS: MILLIMETERS

BASIC MODEL	TOTAL TRAVEL	HALF TRAVEL	A	B
ALS22010	100	50	394.2	109.6
ALS22015	150	75	504.4	164.7

ALS2200 Series ORDERING INFORMATION

Travel (Required)

-100	100 mm
-150	150 mm

Limits (Required)

-LI1	Normally-closed, 5V end-of-travel limit switches
-LI2	Normally-open, 5V end-of-travel limit switches

Metrology (Required)

-PL1	Metrology, uncalibrated with performance plots
-PL2	Metrology, calibrated (HALAR) with performance plots

Integration (Required)

Aerotech offers both standard and custom integration services to help you get your system fully operational as quickly as possible. The following standard integration options are available for this system. Please consult Aerotech if you are unsure what level of integration is required, or if you desire custom integration support with your system.

-TAS	<p>Integration - Test as system</p> <p>Testing, integration, and documentation of a group of components as a complete system that will be used together (ex: drive, controller, and stage). This includes parameter file generation, system tuning, and documentation of the system configuration.</p>
-TAC	<p>Integration - Test as components</p> <p>Testing and integration of individual items as discrete components. This is typically used for spare parts, replacement parts, or items that will not be used or shipped together (ex: stage only). These components may or may not be part of a larger system.</p>