

Aluminum Crossed Roller Guide Motorized Stage

Stage Size 40 × 40 mm / 60 × 60 mm / 100 × 100 mm / 100 × 175 mm

TAMM-XY **RoHS**

Motorized crossed roller stages offer small footprint, low-profile and high durability.



- These linear stages utilize
- anti-creep crossed roller bearings
 - a special nut-shape ball screw.
 - black anodized aluminum body.

Guide

- ▶ Due to the motor offset, a spacer is required when mounting the stage on a flat surface (MSP-40 [▶ WEB Reference](#) [Catalog Code](#) W6035, MSP-60 [▶ WEB Reference](#) [Catalog Code](#) W6036 or Contact our Sales Division for custom spacers) [Reference](#) D055 -
- ▶ After purchasing two X axis stages, to assemble them into an XY axis stage, assembly adjustment cost and performance inspection cost will be charged separately.
- ▶ Contact our Sales Division for other customization options including alternate motors. Or, use the motorized stage system question sheet. [Reference](#) G123 [▶ WEB Reference](#) [Catalog Code](#) W9500

Application Systems

Optics & Optical Coatings

Opto-Mechanics

Bases

Manual Stages

Actuators & Adjusters

Motorized Stages

Light Sources & Laser Safety

Index

Guide

Controllers/Drivers

Softwares

Stepping Motor

AC Servo Motor

Cables

Piezo

X Translation

Theta Rotation

Goniometer

Vacuum

Options

40 × 40 mm

60 × 60 mm

80 × 80 mm

85 × 85 mm

100 × 100 mm

120 × 120 mm

Others

Specifications

Part Number		TAMM40-10C(XY)	TAMM60-15C(XY)	TAMM100-50C(XY)	TAMM100-100C(XY)	
Mechanical Specifications	Travel [mm]	10	15	50	100	
	Stage Size [mm]	40×40	60×60	100×100	100×175	
	Feed Screw	Ball screw diameter ϕ 4mm, 1mm lead	Ball screw diameter ϕ 6mm, 1mm lead	Ball screw diameter ϕ 8mm, 1mm lead	Ball screw diameter ϕ 8mm, 1mm lead	
	Positioning Slide	Crossed roller guide	Crossed roller guide	Crossed roller guide	Crossed roller guide	
	Stage Material	Aluminum	Aluminum	Aluminum	Aluminum	
	Finish	Black anodized	Black anodized	Black anodized	Black anodized	
	Weight [kg]	0.66	0.96	3.8	5.8	
Accuracy Specifications	Resolution	(Full) [μ m/pulse]	2	2	2	2
		(Half) [μ m/pulse]	1	1	1	1
	MAX Speed [mm/sec]	10	10	10	10	
	Load Capacity [N]	24.5 (2.5kgf)	39.2 (4.0kgf)	78.4 (8.0kgf)	68.6 (7.0kgf)	
	Backlash [μ m]	1	1	1	1	
	Orthogonality of Motion [μ m]	5	5	5	5	
Sensor	Sensor Part Number	Micro photo sensor: GP1S092HCPIF(Sharp Corporation)				
	Limit Sensor	Equipped (NORMAL CLOSE)				
	Origin Sensor	Equipped (NORMAL OPEN)				
	Proximity Origin Sensor	None				

Motor / Sensor Specifications

Motor	Type	5-phase stepping motor 0.75A/phase (Oriental Motor Co., Ltd.)	
	Motor Part Number	PK523HPB-C12 (□28mm)	PK544NBW (□42mm)
	Step Angle	0.72°	
Sensor	Power Voltage	DC5 - 24V \pm 10%	
	Current Consumption	120mA or lower (60mA or lower a per axis 20mA or lower per a sensor)	
	Control Output	NPN open collector output DC30V or lower, 50mA or lower	
	Output Logic	In the case of light shielded ,output transistor OFF (No conduction): Limit sensor In the case of light shielded ,output transistor ON (Conduction): Origin sensor	

Compatible Driver / Controller

Control System	Compatible Driver	SG-5M, SG-5MA, MC-S0514ZU, SG-514MSC, MC-7514PCL	SG-5M, MC-S0514ZU, SG-514MSC, MC-7514PCL
	Compatible Controller	GSC-02, SHOT-702, SHOT-302GS, SHOT-304GS, HIT-M, HIT-S, PGC-04-U, HSC-103	SHOT-702, SHOT-302GS, SHOT-304GS, HIT-M, HIT-S, PGC-04-U, HSC-103



Outline Drawing

TAMM40-10C(XY)

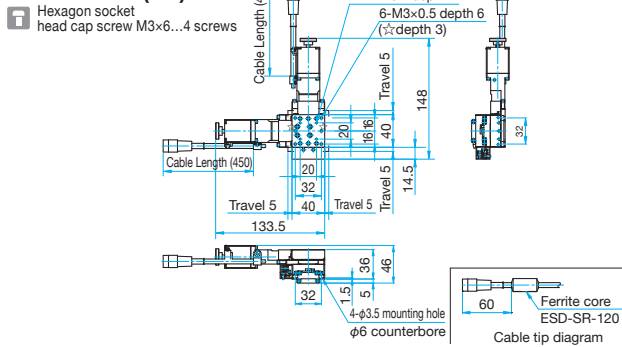

TAMM60-15C(XY)

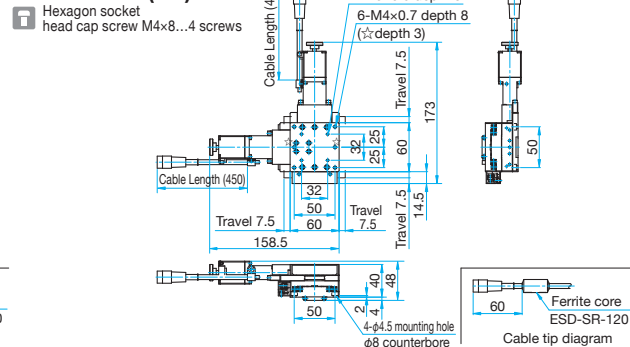

Connection Diagram

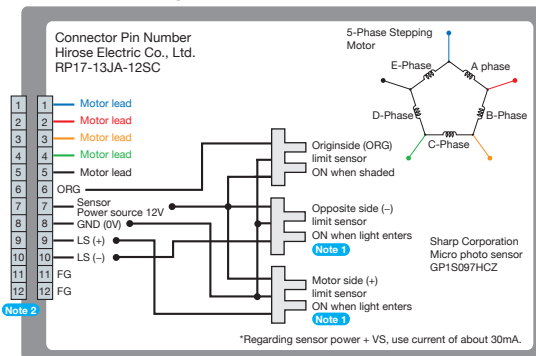

Note 1 The motor side limit sensor is the + direction limit sensor. Motorized stages are not fitted with proximity origin sensors.
Note 2 Compatible cable connector: Hirose Electric Co., Ltd. RP17-13PA-12PC/RP17-PC-122

Compatible Controllers / Drivers and Cables

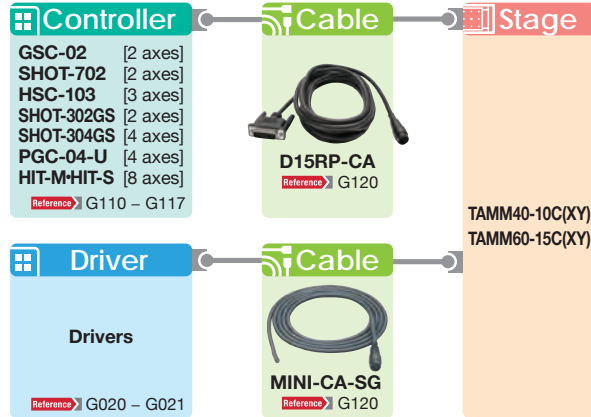

TAMM100-50C(XY)

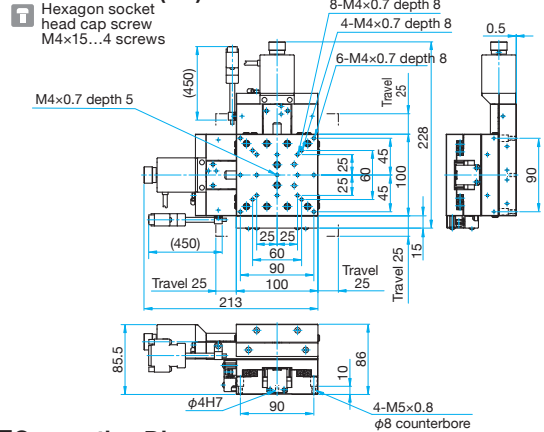

TAMM100-100C(XY)

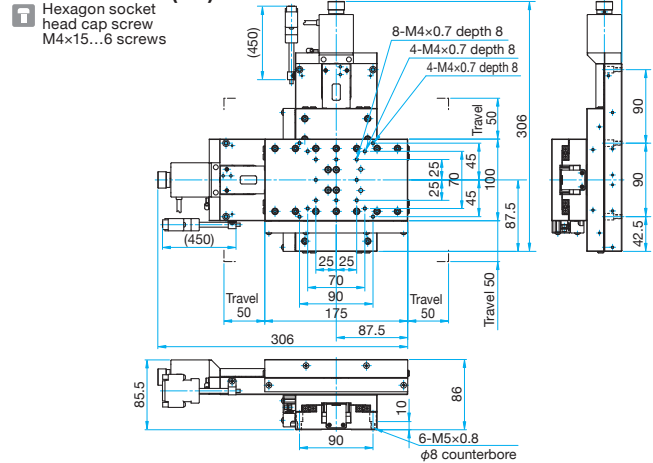

Connection Diagram

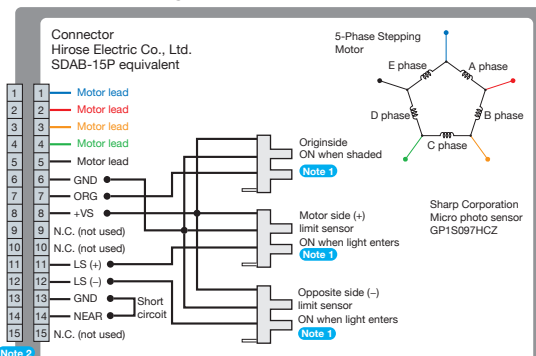

Note 1 The motor side limit sensor is the + direction limit sensor. Motorized stages are not fitted with origin and proximity origin sensors.
Note 2 Compatible cable connector: DDK Ltd. 17JE-13150

Compatible Controllers / Drivers and Cables

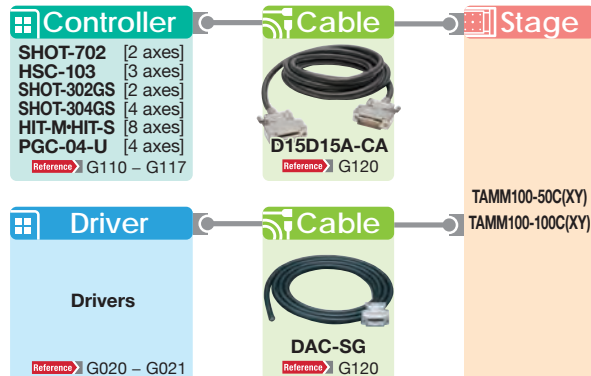

Application Systems

Optics & Optical Coatings

Opto-Mechanics

Bases

Manual Stages

Actuators & Adjusters

Motorized Stages

Light Sources & Laser Safety

Index

Guide

Controllers/Drivers

Softwares

Stepping Motor

AC Servo Motor

Cables

Piezo

X Translation

Theta Rotation

Goniometer

Vacuum

Options

40 x 40 mm

60 x 60 mm

80 x 80 mm

85 x 85 mm

100 x 100 mm

120 x 120 mm

Others