

X Axis Steel Extended Contact Translation Stages -M6

Stage Size 65 × 65 mm

TSD-651

RoHS

Hardened steel linear translation stages with integrated bearing ways and a black chrome finish. Our “Extended Contact” technology yields superior stability, stiffness, accuracy, and durability.



Guide

- ▶ Vacuum-compatible stainless steel stages (TSDS-651) are also available. [Reference](#) E206 [Catalog Code](#) W7005
- ▶ Bottom counter bore clearance holes are sized and spaced to accept both M6 or 1/4 size screws for mounting these stages down to a table.
- ▶ Both M6 or 1/4-20 inch tapped hole versions available.
- ▶ Both left and right hand adjustment versions available.
- ▶ Multiple actuator options available. Standard micrometer, sub-micron micrometer, fine pitch screw.
- ▶ All stages are equipped with a robust knurled head locking screw.

Attention

- ▶ Micrometer brackets may extend above the top surface of some stages. Check drawings for more information.

Specifications

Part Number	METRIC	TSD-651C-M6	TSD-651S-M6	TSD-651C25-M6	TSD-651S25-M6
	INCH	TSD-651CUU	TSD-651SUU	TSD-651C25UU	TSD-651S25UU
(Opposite Model)	METRIC	—	TSD-651SR-M6	—	—
Guide	INCH	—	TSD-651SRUU	—	—
Stage Size [mm]		65×65	65×65	65×65	65×65
Axes of Travel		X axis			
Micrometer Position		Center	Side	Center	Side
Travel [mm]		±6.5	±6.5	±12.5	±12.5
Lead of Actuator [mm/rotation]		0.5	0.5	0.5	0.5
Micrometer Readable Resolution [mm]		0.01	0.01	0.01	0.01
Guide Method		Extended contact ball bearing guide			
Primary Material		Steel			
Finish		Super black chrome			
Load Capacity [N]		294 (30.0kgf)	294 (30.0kgf)	294 (30.0kgf)	294 (30.0kgf)
Travel Accuracy	Straightness [μm]	0.5	0.5	0.5	0.5
	Pitch [″]	25	25	25	25
	Yaw [″]	15	15	15	15
Max. Moment Capacity	Pitch [N·m]	13.2	13.2	13.2	13.2
	Roll [N·m]	14.7	14.7	14.7	14.7
	Yaw [N·m]	10	10	10	10
Moment Stiffness	Pitch [°/N·cm]	0.08	0.08	0.08	0.08
	Roll [°/N·cm]	0.05	0.05	0.05	0.05
	Yaw [°/N·cm]	0.08	0.08	0.08	0.08
Parallelism [μm]		15	15	15	15
Running Parallelism [μm]		7	7	7	7
Options		FP ¹ /DM/WP/DL	FP ¹ /DM/WP/DL	FP ²	FP ²
Weight [kg]		0.6	0.6	0.6	0.6

Option

Option Code	Compatible product		Lead of Actuator [mm/rotation]	Micrometer Readable Resolution [mm]	Reference
	Products Name	Part Number			
FP	Fine-pitch Screw Adjusters	FPSA-62540 ¹ FPSA-62550 ²	0.25	—	E008
DM	Differential Micrometer Heads	MHF2-13F	Coars: 0.5 Fine: 0.025	Coars: 0.01 Fine: 0.0005	
WP	Sub-micron Worm Drive Micrometer Heads	WGP-13	Coars: 0.25 Fine: 0.005	Coars: 0.005 Fine: 0.0005	
DL	Differential Micrometer Heads	MDC-13	0.5	0.01	

* Please add an option code as the part number suffix to specify various optional specifications.

* Installation may not be possible depending on the direction of DL.

* Replacement work requires a special tool (MNS). [Reference](#) F006z [Catalog Code](#) W8005

Application Systems

Optics & Optical Coatings

Opto-Mechanics

Bases

Manual Stages

Actuators & Adjusters

Motorized Stages

Light Sources & Laser Safety

Index

Guide

X Axis Stages

XY Axis Stages

Z Axis Stages

XZ Axis Stages

XYZ Axis Stages

Rotation Stages

Goniometer

Tilt Stages

Vacuum

Ball Bearing Guide

Crossed Roller

Dovetail

Lapping

V Groove Screw

Others

15 × 15 mm

25 × 25 mm

40 × 40 mm

60 × 60 mm

65 × 65 mm

80 × 80 mm

100 × 100 mm

120 × 120 mm

Others



Outline Drawing

TSD-651C-M6/651CUU Hexagonal socket head cap screw M6x6...4 screws (M6)
Hexagonal socket head cap screw 1/4-20UNCx1/4...4 screws (UU)

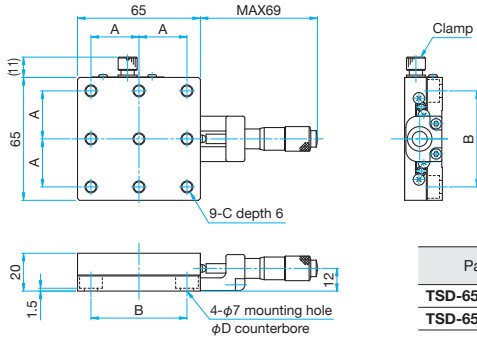

Part Number	A (mm)	B (mm)	C	D (mm)
TSD-651C-M6	25	50	M6 P1	11
TSD-651CUU	25.4	50.8	1/4-20UNC	12

TSD-651S-M6/651SUU Hexagonal socket head cap screw M6x6...4 screws (M6)
Hexagonal socket head cap screw 1/4-20UNCx1/4...4 screws (UU)

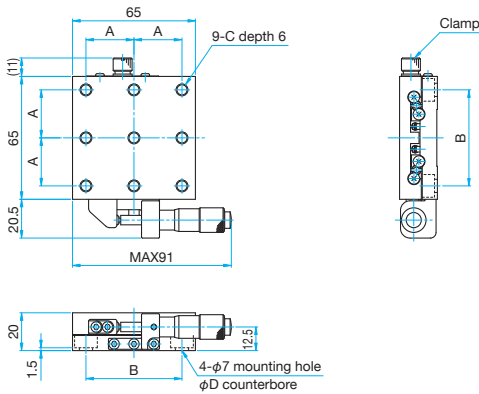

Part Number	A (mm)	B (mm)	C	D (mm)
TSD-651S-M6	25	50	M6 P1	11
TSD-651SUU	25.4	50.8	1/4-20UNC	12

TSD-651SR-M6/651SRUU Hexagonal socket head cap screw M6x6...4 screws (M6)
Hexagonal socket head cap screw 1/4-20UNCx1/4...4 screws (UU)

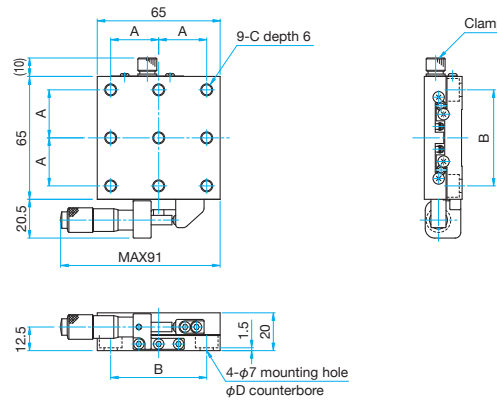

Part Number	A (mm)	B (mm)	C	D (mm)
TSD-651SR-M6	25	50	M6 P1	11
TSD-651SRUU	25.4	50.8	1/4-20UNC	12

TSD-651C25-M6/651C25UU Hexagonal socket head cap screw M6x6...4 screws (M6)
Hexagonal socket head cap screw 1/4-20UNCx1/4...4 screws (UU)

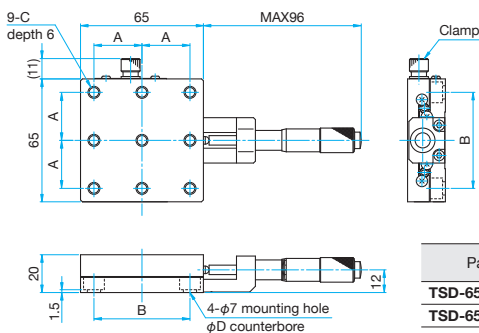

Part Number	A (mm)	B (mm)	C	D (mm)
TSD-651C25-M6	25	50	M6 P1	11
TSD-651C25UU	25.4	50.8	1/4-20UNC	12

TSD-651S25-M6/651S25UU Hexagonal socket head cap screw M6x6...4 screws (M6)
Hexagonal socket head cap screw 1/4-20UNCx1/4...4 screws (UU)

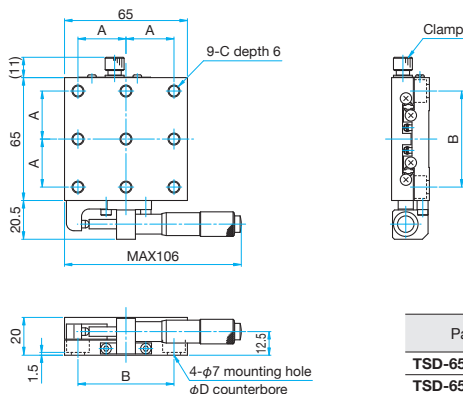

Part Number	A (mm)	B (mm)	C	D (mm)
TSD-651S25-M6	25	50	M6 P1	11
TSD-651S25UU	25.4	50.8	1/4-20UNC	12

Application Systems

Optics & Optical Coatings

Opto-Mechanics

Bases

Manual Stages

Actuators & Adjusters

MotORIZED Stages

Light Sources & Laser Safety

Index

Guide

X Axis Stages

XY Axis Stages

Z Axis Stages

XZ Axis Stages

XYZ Axis Stages

Rotation Stages

Goniometer

Tilt Stages

Vacuum

Ball Bearing Guide

Crossed Roller

Dovetail

Lapping

V Groove Screw

Ohters

15 × 15 mm

25 × 25 mm

40 × 40 mm

60 × 60 mm

65 × 65 mm

80 × 80 mm

100 × 100 mm

120 × 120 mm

Others