

# End Driven Linear Stages

Optics

Lenses

Mirrors & Beamsplitters

Prisms & Polarizers

Filters

Pinholes

- 25 mm (1 inch) travel
- Precision pre-loaded ball bearing slides
- Choice of 4 different actuator types
- One piece machined aluminum body
- Tracking accuracy 4  $\mu\text{m}$
- 1/4-20 (M6) hole patterns



Ealing's MacroMech stages are designed for positioning medium weight loads with a high degree of accuracy and stability. All 25 mm linear stages feature a positioner body machined from a single piece of aluminum, providing exceptional rigidity. High accuracy and smoothness of operation are achieved by the use of pre-loaded, high precision ball bearing slides, individually adjusted and tested during assembly. Spring-loaded guides maintain contact between translation stage and actuator driving head, ensuring minimal 'stiction' and backlash.

MacroMech 25 mm linear stages are supplied with either a thumbscrew drive actuator or with a micrometer which is clearly marked for 0.01 mm accuracy over the full 25 mm of travel

(1/2 division is equal to 5  $\mu\text{m}$ ). The micrometer drive can be easily removed from the stage. It can then be replaced with either a MotorDriver or EncoderDriver Actuator.

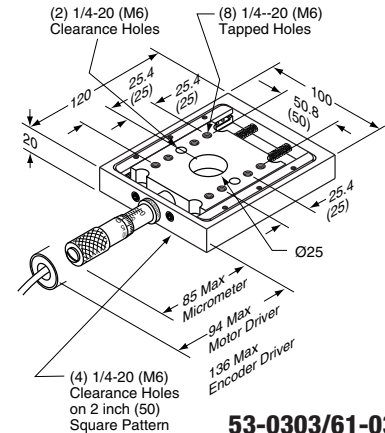

**53-0303/61-0303**  
End Driven Linear Stage  
with Micrometer

## Specifications

**Range:** 25 mm (1 inch)

**Minimum Incremental Motion -**

Thumbscrew Actuator: 1  $\mu\text{m}$

Micrometer Actuator: 1  $\mu\text{m}$

MotorDriver Actuator: 0.1  $\mu\text{m}$

EncoderDriver Actuator: 0.05  $\mu\text{m}$

**Tracking Accuracy:** 4  $\mu\text{m}$

**Reading Accuracy:** 1 division = 10  $\mu\text{m}$   
(on micrometer version)

**Load Capacity -**

Horizontal: 12 kg

Vertical: 0.5 kg (4 kg with drive  
below the stage)

**Weight (with micrometer):** 0.9 kg (2 lb)

**Construction:** One piece aluminum  
body, steel precision ground slides  
and stage.

## End Driven Linear Stages (Metric)

Catalog Number	Description
53-0303	MacroMech End Driven Linear Stage, 25 mm Travel, Micrometer Drive, Metric Hole Patterns
37-0015	25 mm MotorDriver Actuator
37-1062	25 mm EncoderDriver Actuator

## End Driven Linear Stages (Inch)

Catalog Number	Description
61-0303	MacroMech End Driven Linear Stage, 1 inch Travel, Micrometer Drive, Inch Hole Patterns
37-0015	25 mm MotorDriver Actuator
37-1062	25 mm EncoderDriver Actuator

Opto-mechanics

Breadboards & Rails

Mounting Hardware

Mirror & Component Mounts

Manual Micro Positioners

Motorized Positioners